



# **Lithium-Ion Phosphate (LFP) Battery Energy Storage System Force-H2-V2 Operation Manual**

Information Version: 1.2

5PMPA08-00194



# Legal Information

**Copyright©2024 Pylon Technologies Co., Ltd. All rights reserved.**

Any reproduction or distribution of this manual or any part of this manual, or any uploading of this manual to a third party website, in any form by any means, without the prior written consent of Pylon Technologies Co., Ltd., is prohibited.

## **Disclaimer**

The manual contains instructions for the use of the product. All the pictures and charts in this manual are for description and explanation only. Pylon Technologies Co., Ltd. reserves the right to change the information in the manual which is subject to change without further notice.

Please read this manual carefully before using the product and keep this manual for further reference. Failure to use the product in accordance with the manual may result in serious injuries, property damages and may void the warranty, for which Pylon Technologies Co., Ltd. shall not be liable.

Pylon Technologies Co., Ltd. makes no representations or warranties express or implied, with respect to all the information in this manual.

In the event of any conflicts between this manual and the applicable law, the latter prevails.

The final interpretation of this manual belongs to Pylon Technologies Co., Ltd.

# Contents

<b>1</b>	<b>Information about this manual .....</b>	<b>1</b>
1.1	Purpose.....	1
1.2	Explanation of symbols.....	1
1.3	Abbreviations in this manual.....	1
<b>2</b>	<b>Safety.....</b>	<b>2</b>
2.1	Symbols.....	2
2.2	Personal Requirements .....	3
2.3	General Safety.....	4
2.4	Safety Instructions Before Connecting the Battery.....	6
2.5	Safety Instructions in Using the Battery .....	6
<b>3</b>	<b>System Introduction .....</b>	<b>7</b>
3.1	System Description .....	7
3.1.1	System Overview .....	7
3.1.2	Single String System Specifications.....	8
3.1.3	Multi-string System Parameters (maximum 6 Strings per System).....	10
3.2	Battery Module .....	11
3.2.1	Battery Module Specifications.....	11
3.2.2	Capacity Expansion .....	12
3.3	Control Module.....	13
3.3.1	Control Module Display Panel.....	13
3.3.2	Control Module Interface Panel.....	16
3.4	System Diagram .....	20
<b>4</b>	<b>Installation .....</b>	<b>21</b>
4.1	Checking Before the Installation.....	21
4.2	Preparing tools and instruments.....	22
4.3	Selecting the Installation Sites .....	23
4.3.1	Working Environment Requirements.....	23
4.3.2	Installation Space Requirements.....	25
4.3.3	Installation Foundation Requirements.....	25
4.4	System Installation .....	26



4.4.1	Mounting the Battery Bottom Base.....	26
4.4.2	Battery Modules and Control Module (BMS) Pile up .....	27
4.4.3	Installing the Metal Brackets for the System.....	28
4.4.4	Fixing Screws on the Display Panel and Interface Panel of the Control Module.....	30
4.4.5	Installing the Anti-Toppling Brackets for the System.....	30
<b>5</b>	<b>Cable Connection .....</b>	<b>35</b>
5.1	Checking cables.....	35
5.2	Grounding .....	36
5.3	Multi-string Cable Connections.....	37
5.3.1	Electrical Wiring.....	37
5.3.2	Communication Cable Connections of Master and Slave Battery Strings.....	39
<b>6</b>	<b>Commissioning .....</b>	<b>40</b>
6.1	System Turning On.....	40
6.1.1	Single String System Turning On.....	40
6.1.2	Multi-strings System Turning On.....	42
6.2	System Debug.....	43
<b>7</b>	<b>Maintenance.....</b>	<b>44</b>
7.1	System Turning Off.....	44
7.2	Battery Maintenance .....	45
7.3	Troubleshooting .....	46
7.4	Replacement of main components among the BESS.....	48
7.4.1	Replacement of Battery module .....	48
7.4.2	Replacement of Control module.....	50
<b>8</b>	<b>Shipment and Storage .....</b>	<b>51</b>
8.1	Shipment.....	51
8.2	Storage .....	51
<b>9</b>	<b>Disposal.....</b>	<b>52</b>
	<b>Annex 1: Installation and System Turn-on Process List .....</b>	<b>53</b>
	<b>Annex 2: System Turn-off Process List.....</b>	<b>54</b>

# 1 Information about this manual

## 1.1 Purpose

This manual describes the Force-H2-V2 from Pylontech in terms of its overview, installation, commissioning, maintenance, etc. Please read this manual before installing the battery and follow the instructions carefully during installation. In case of any confusion, please contact Pylontech immediately for advice and clarification (Contact information can be found on the back cover of the manual).

## 1.2 Explanation of symbols







Symbol	Description
 <b>DANGER</b>	<b>Danger:</b> Indicates a hazard with a high level of risk which, if not avoided, will result in death or serious injury.
 <b>WARNING</b>	<b>Warning:</b> Indicates a hazard with a medium level of risk which, if not avoided, could result in death or serious injury.
 <b>CAUTION</b>	<b>Caution:</b> Indicates a hazard with a low level of risk which, if not avoided, could result in minor or moderate injury.





## 1.3 Abbreviations in this manual

Abbreviation	Designation
Pylontech	Pylon Technologies Co., Ltd.
QC	Quality Control
BMS	Battery Management System
PCS	Power Conversion System
SOC	State of Charge
UPS	Uninterruptible Power Supply
BESS	Battery Energy Storage System
EMS	Energy Management System

## 2 Safety

### 2.1 Symbols

	Read the manual before installing and operating the battery system.
	General warning label indicating potential hazards.
	Warning: electric shock!
	Warning: flammable materials.
	Do not connect the positive and negative reversely.
	Keep away from flame or ignition sources.
	Keep away from children.

	<p>Recycle label.</p>
	<p>Label for Waste Electrical and Electronic Equipment (WEEE) Directive (2012/19/EU)</p>
	<p>The certificate label for EMC.</p>
	<p>The certificate label for Safety by TÜV SÜD.</p>

## 2.2 Personal Requirements

Qualified personnel must have the following skills:

- Training in the installation and commissioning of the electrical system, as well as the dealing with hazards.
- Knowledge of the manual and other related documents.
- Knowledge of the local regulations and directives.



## 2.3 General Safety

### Declaration

This system is only operated by authorized personnel. Read all safety instructions carefully prior to any work and follow these instructions at all times when working with the system.

Incorrect operation or work may cause:

- Injury or death to the operator or a third party.
- Damage to the system hardware and other properties belonging to the operator or a third party.

### General Requirements

#### DANGER

**Danger:** Batteries deliver electric power, resulting in burns or a fire hazard when short circuit or incorrect installment occurs.

#### DANGER

**Danger:** Lethal voltages are present in the battery terminals and cables. Severe injuries or death may occur if you touch the cables and terminals.

#### DANGER

**Danger:** Battery strings will produce high voltage DC power and can cause a lethal voltage and an electric shock. Only qualified personnel can perform the wiring of the battery strings.

#### WARNING

**Warning:** DO NOT open or deform the battery module, otherwise the product will be out of warranty scope.

#### WARNING

**Warning:** Whenever operating the battery system, wear suitable personal protective equipment (PPE) such as rubber gloves, rubber boots and goggles.

#### WARNING

**Warning:** For this system, working temperature is  $-10^{\circ}\text{C} \sim 55^{\circ}\text{C}$  and the optimum temperature is:  $18^{\circ}\text{C} \sim 28^{\circ}\text{C}$ . Out of the working temperature range may cause the battery system over/low temperature alarm or protection which will further lead to the cycle life reduction. It will affect the warranty terms as well.

 **WARNING**

**Warning:** For battery installation, the installer shall refer to NFPA70 or similar local installation standard for operation.

 **WARNING**

**Warning:** Pulling out the connectors while the system is working could lead to battery system damage or personal injury. Do not pull out the connectors while system is in operation. De-energize all multiple power sources and verify that there is no voltage.

 **CAUTION**

**Caution:** Improper settings or maintenance can permanently damage the battery.

 **CAUTION**

**Caution:** Incorrect inverter parameters will lead to the premature aging of battery or battery system failure.

 **CAUTION**

**Caution:**

- It is very important and necessary to read the user manual carefully before installing or using the battery. Failure to do so or to follow any of the instructions or warnings in this document can result in electrical shock, serious injury, death, or can damage battery, potentially rendering it inoperable.
- If the battery is stored for long time, it is required to charge them every six months, and the SOC should be no less than 90%.
- Battery needs to be recharged within 12 hours, after fully discharged.
- Do not expose cables outside.
- Please keep the battery away from radiation environment installation.
- Please avoid installing batteries in earthquake-prone areas.
- Please keep the battery away from corrosive gases and liquid areas.
- In the battery installation area, please reserve a safe escape route and indicate it with a symbol.
- This device is not equipped with a fire alarm system, please prepare yourself with a sound-light alarm in the battery installation area.

## 2.4 Safety Instructions Before Connecting the Battery

### CAUTION

#### Caution:

- After unpacking, please check product and packing list first, if the product is damaged or lack of parts, please contact the local retailer.
- Before installation, be sure to cut off the grid power and make sure the battery is in the switched-off mode.
- Wiring must be correct, do not mistake the positive and negative cables, and ensure no short circuit with the external device.
- DO NOT connect the battery with AC power directly.
- Battery system must be well grounded and the resistance must be less than 100mΩ.
- Please ensure that the electrical parameters of battery system are compatible to related equipment.
- Keep the battery away from water and fire.

## 2.5 Safety Instructions in Using the Battery

### CAUTION

#### Caution:

- If the battery system needs to be moved or repaired, the power must be cut off and the battery is completely shut down in advance.
- DO NOT connect the battery with other different types of battery.
- DO NOT let the batteries work with faulty or incompatible inverter.
- DO NOT disassemble the battery (QC tab removed or damaged).
- This device is not equipped with a fire alarm system, please prepare yourself with a smoke alarm in the battery installation area.
- In case of fire, only dry powder fire extinguisher can be used. DO NOT use liquid fire extinguishers.

## 3 System Introduction

### 3.1 System Description

#### 3.1.1 System Overview

Force-H2-V2 is a high voltage battery storage system based on lithium iron phosphate battery, which is one of the new energy storage products developed and produced by Pylontech. It can be used to provide reliable power for various types of equipment and systems. Force-H2-V2 enables multiple strings parallel operation feature, which provides tremendous flexibility in system design and configuration. Force-H2-V2 is especially suitable for those application scenarios which require high power output, limited installation space, restricted load-bearing and long cycle life.



**Fig. 3-1: Force-H2-V2**

**NOTE:** The above picture is just for reference. The quantity of the battery modules is based on your practical system.

### 3.1.2 Single String System Specifications

Product Type	Force-H2-V2				
Cell Technology	Li-iron (LFP)				
Battery System Capacity (kWh)	3.55	7.10	10.65	14.20	17.76
Battery System Voltage (VDC)	96	192	288	384	480
Battery System Capacity (Ah)	37				
Battery Controller Model	FC0500M-40S-V2				
Battery Module Model	FH9637M				
Battery Module Quantity	1	2	3	4	5
Battery Module Capacity (kWh)	3.552				
Battery Module Voltage (VDC)	96				
Battery Module Capacity (Ah)	37				
Battery System Charge Upper Voltage (VDC)	108	216	324	432	540
Battery System Charge Current (Amps, Standard)	7.4				
Battery System Charge Current (Amps, Normal)	18.5				
Battery System Charge Current (Amps, maximum @ 15 seconds)	42				
Battery System Discharge Lower Voltage (VDC)	87	174	261	348	435
Battery System Discharge Current (Amps, Standard)	7.4				
Battery System Discharge Current (Amps, Rated)	18.5				

Product Type	Force-H2-V2				
Battery System Discharge Current (Amps, maximum @ 15 seconds)	42				
Short circuit rating (Amps)	< 4000				
Efficiency (%)	96				
Depth of Discharge (%)	95				
Dimension (W x D x H, mm)	450 x 296 x 296	450 x 296 x 822	450 x 296 x 1118	450 x 296 x 1414	450 x 296 x 1710
Communication	CANBUS/Modbus RTU				
Protection Class	IP55				
Weight (kg)	45	78	111	144	177
Operation Life (year)	15+				
Operation Temperature (°C) *	-10~55				
Storage Temperature (°C)	-20~60				
Altitude (m)	< 4,000				
Humidity (%)	5~95				
Product Certificate	VDE-AR-E 2510-50, IEC62619, IEC63056, IEC62040-1, 2014/53/EU(RED)				
Transfer Certificate	UN38.3				
Battery Controller Dimensions (mm)	450 (w) × 296 (D) × 190 (H)				
Battery Module Dimensions (mm)	450 (W) × 296 (D) × 296 (H)				
Battery bottom base Dimensions (mm)	450 (W) × 296 (D) × 40 (H)				

\* In high (> 45°C) or low temperature (< 10°C) environment, the charging and discharging power of the battery system will be limited according to BMS operation logic.

### 3.1.3 Multi-string System Parameters (maximum 6 strings per system)

For multi-strings operation, ensure that:

- The battery type in the whole system is the same.
- The battery amount of each string is the same.

Specifications	Force-H2-V2 in multi-strings				
Battery System Voltage (VDC) *	96/192/288/384/480				
Battery System string amount	<b>2</b>	<b>3</b>	<b>4</b>	<b>5</b>	<b>6</b>
Battery System capacity (Ah)	74	111	148	185	222
Battery System Operation Current (Amps, Standard)	14.8	22.2	29.6	37	44.4
Battery System Operation Current (Amps, Normal)	37	55.5	74	92.5	111
Battery System Operation Current (Amps, Max.@15 seconds)	84	126	168	210	252
P-Combiner 3/6 Operation Current (Amps, Normal)	50**		100*□		
P-Combiner 3/6 Operation Current (Amps, Max.@15 seconds)	80**		160*□		

\*The Battery System Voltage varies depending on battery amount in serial per string.

\*\*The current is based on BMS theoretical operation current. If using P-Combiner 3 as the combiner box of the multi-strings` battery system wiring connection, the maximum continuous operation current is 50 Amps, maximum peak operation current is 80 Amps for 15 seconds. for the battery system. Please ensure that the real operation current does not exceed the combiner box power rating.

\*\*\*The current is based on BMS theoretical operation current. If using P-Combiner 6 as the combiner box of the multi-strings` battery system wiring connection, the maximum continuous operation current is 100 Amps, maximum peak operation current is 160 Amps for 15 seconds for the battery system. Please ensure that the real operation current does not exceed the combiner box power rating.

**NOTE: DO NOT** use P-Combiner-HV-3/6-V2 or similar concept of multi-strings connection method in case the multiple battery strings need to be operated independently.

## 3.2 Battery Module

### 3.2.1 Battery Module Specifications

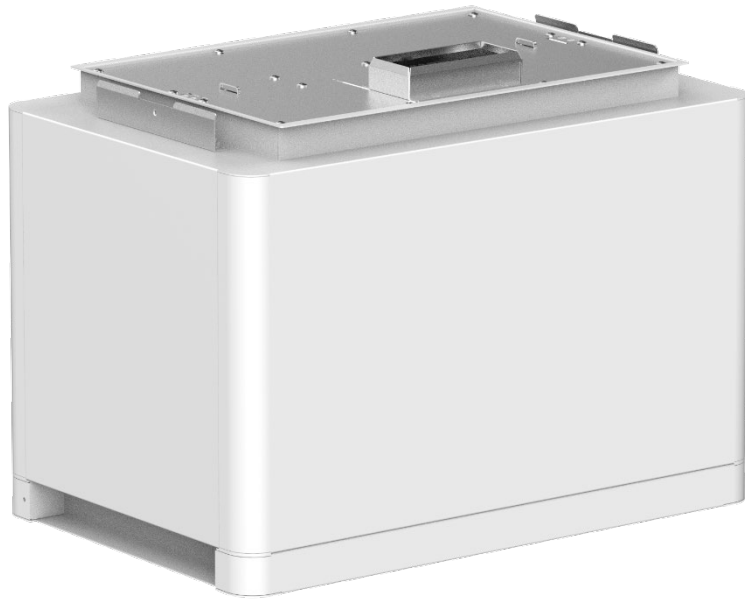

Fig. 3-2: Battery Module

Product Model	FH9637M
Cell Technology	Li-ion (LFP)
Battery Module Capacity (kWh)	3.552
Battery Module Voltage (VDC)	96
Battery Module Capacity (Ah)	37
Battery Module Serial Cell Quantity (pcs)	30
Battery Cell Voltage (VDC)	3.2
Battery Cell Capacity (Ah)	37
Dimension (mm)	450 (w) x 296 (D) x 296 (H)
Weight (kg)	35
Operation Life (year)	15+
Operation Cycle Life (cycle)*	8,000
Operation Temperature (°C) **	-10~55
Storage Temperature (°C)	-20~60
Transfer Certificate	UN38.3

\* Operation Cycle Life is defined based on specific operation conditions, for more details please check with Pylontech service team.

\*\* In high(>45°C) or low temperature(<10°C) environment, the charging and discharging power of the battery system will be limited according to BMS operation logic.



### **3.2.2 Capacity Expansion**

A new battery module can be added onto an existing system at any time. Please ensure that the new battery module has an equivalent OCV (Open Circuit Voltage) compared to existing modules before adding on and make a full charge of the new system. In a serial connection system, the new module, even with a higher SOH, shall follow the system worst SOH condition module to perform.

### 3.3 Control Module

#### 3.3.1 Control Module Display Panel

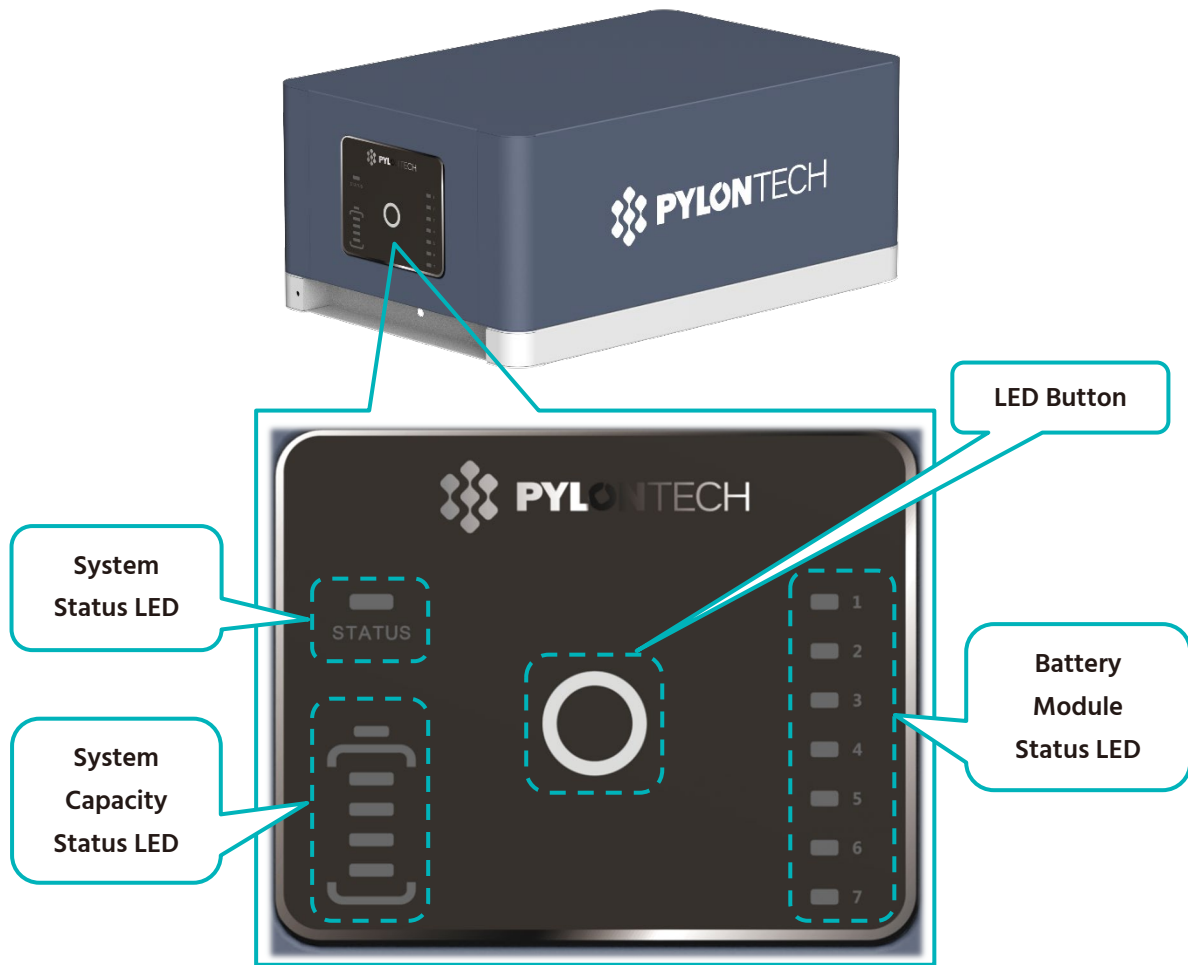



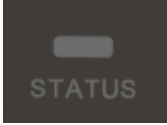



Fig. 3-3: Control Module Display Panel

#### LED Button

Button	Action	Instructions
	Short Press	Display the LED panel for 20 seconds.
	Long Press 1 (about 5~10 seconds)	(1) When System Status LED fast flashes blue  , release the button, then it is 115200 baud rate of RS485. (2) When System Status LED fast flashes orange  , release the button, then it is 9600 baud rate of RS485. (3) If a special protocol (except Pylontech Protocol) is selected, follow 'Long Press 2', then the baud rate changing described here is ineffective.
	Long Press 2 (>10 seconds)	Communication Protocol Selection, for details please check with Pylontech service team. Communication Protocol Selection Guidance.

## System Status LED

		<p>Refer to Instructions of the <i>LED Indicators Instructions</i> below.</p>
		

## Battery Module Status LED

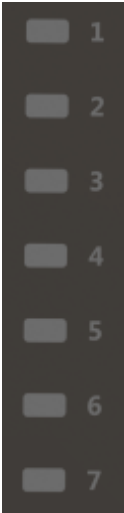
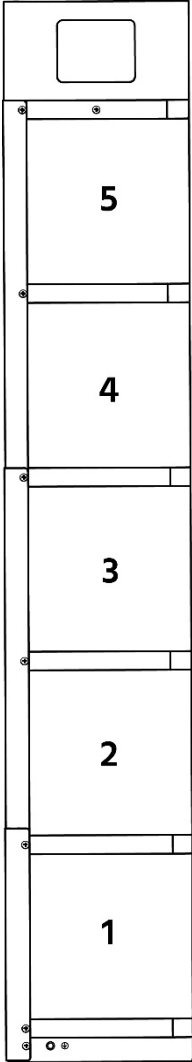
		<p>Blue light</p>	<p>Normal</p>
		<p>Orange light</p>	<p>Individual module alarm or protection occurs. See trouble shooting steps in <i>section 7.3</i>.</p>











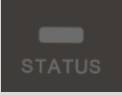





### Instructions:

- (1) Each Status LED (1~5) represents one individual battery module from number 1 (the one next to the base) to number 5 (the one right beneath the control module), as shown in the above illustration.
- (2) If your system has less than 7 battery modules, the Status LED without corresponding battery will be always OFF.

## System Capacity Status LED

	<p>Indicates the system SOC. Each LED indicates 25%SOC</p>
---	--

## LED Indicators Instructions

Status			Remark
Self-checking	 Blue, Flashing*	All flashing*	
Self-checking failure	 Orange, Slow flashing**	Off	See trouble shooting steps in <i>section 7.3.</i>
Black start success	 Blue, fast flashing*	Off	
Black start failure	 Orange, fast flashing*	Off	See trouble shooting steps in <i>section 7.3.</i>
Communication Lost or BMS error	 Orange, solid	 Indicating SOC, Blue, solid	See trouble shooting steps in <i>section 7.3.</i>
Idle	 Blue, slow flashing**	 Indicating SOC, Blue, solid	
Charge	 Blue, solid	 Indicating SOC, blue, solid	
Floating charge	 Blue, solid	 All flashing, horse race lamp	
Discharge	 Blue, flashing*	 Indicating SOC, blue, solid	
System sleep	 Blue, flashing*	Off	Battery module status off.

\* Flashing: 0.5s ON/0.5s OFF.

\*\*Slow flashing: 2.0s ON/1.0s OFF.

\*\*\*Fast flashing: 0.1s ON/0.1s OFF.

### 3.3.2 Control Module Interface Panel

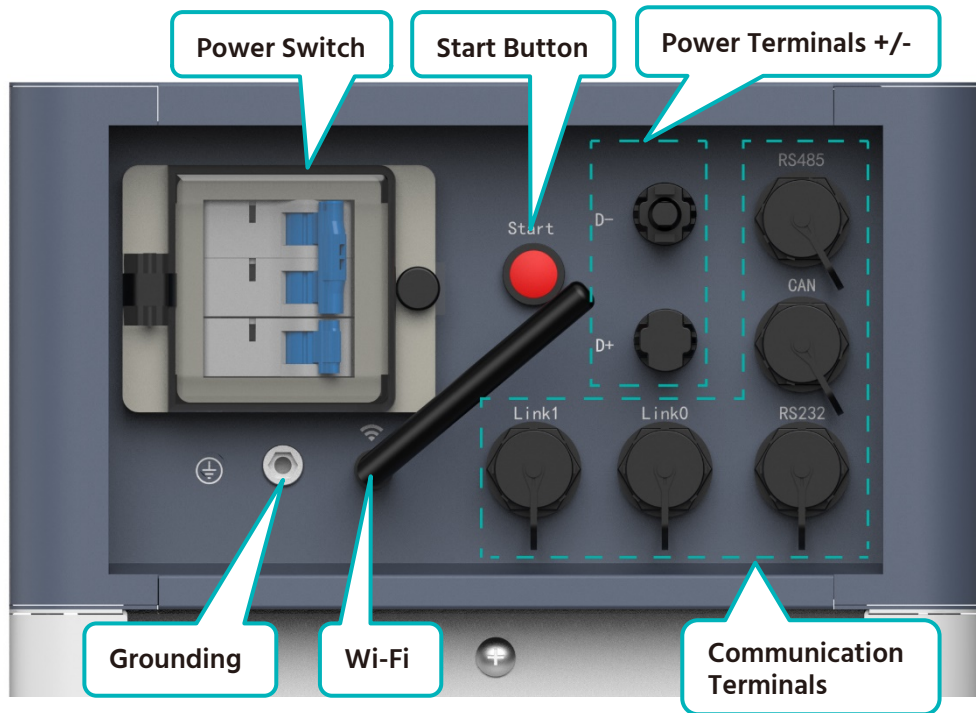

#### Power Switch

**ON:** Power Switch ON, able to turn on battery system by Start Button.

**OFF:** Power Switch OFF, able to turn off system completely, no power output.

#### **CAUTION**

**Caution:** If the power switch is tripped off due to over current or short circuit, be sure to **wait more than 30 minutes**, then you can turn it on again; otherwise it may cause damage to the switch.

**NOTE:** After using the power switch, lock the protection cover by tightening the two screws on the cover to make it water-proof.

#### Start Button

#### **CAUTION**

**Caution:** Press the Start button and hold more than 5 seconds until the buzzer rings to turn on the control module.



**Power on:** Press and hold  $\geq 5\text{sec}$  till the buzzer rings  
**Mise sous tension:** Appuyez et maintenez  $\geq 5\text{sec}$  jusqu'à ce que le buzzer sonne

**Multi-string starting sequence:** please start up the last string (from communication structure, the last slave string, see the table below) of battery system first, one by one to the first string which shall be started up lastly. Details as below table.

Communication Structure	Startup Sequence
Master string*	Last Start up
Slave string 1	5th Start up
Slave string 2	4th Start up (if has)
Slave string 3	3rd Start up (if has)
Slave string 4	2nd Start up (if has)
Slave string 5	1st Start up (if has)

\* BMS of the string with Link Port 0 EMPTY is defined as the Master string, which communicates with the inverter or upper controller. In one system, there's ONLY ONE Master string, the rest are defined as the slave strings.

**Black start function:** When the system is turned on, and relay is OPEN, press the Start Button more than 10 seconds. Then relay will be CLOSE for about 10 minutes without communication (depending on conditions).

**Multi-string Black Start:** Black start operation is ONLY needed to be performed on the Master string. And it will close circuit for one of the strings within the system for 10 minutes. The slave string black start function is ONLY controlled by the master string.

### Power Terminals (+/-)

Connect power cables of battery system with inverter.

During multi-strings operation, you can select P-Combiner-HV-3-V2 (up to 3 strings, maximum 50 Amps) or P-Combiner-HV-6-V2 (up to 6 strings, maximum 100 Amps) for connection. For more details of P-Combiner, please check with your distributor or Pylontech service team.

### Communication Terminals (RS485 / CAN / RS232/Link0/Link1)

RS485 Communication Terminal: (RJ45 port) follows MODBUS 485 protocol, for communication between battery system and inverter.

CAN Communication Terminal: (RJ45 port) follows CAN protocol, for communication between battery system and inverter.

RS232 Communication Terminal: (RJ45 port) for manufacturer or professional engineer to debug or service. The Pin1&2(12VDC+/-) is dedicated for Sunny Boy Storage Enable Line design.

Link0/Link1 Communication Terminal: (RJ45 port) for multi-groups operation using only, connecting from the first BMS Link 1 to the second BMS Link 0, then from the second BMS Link 1 to the third BMS link 0 (if has), all the way to the last BMS Link 0. The BMS with Link Port 0 EMPTY is defined as the Master string, which further communicates with the inverter or upper controller.

For multi-groups operation, please firstly make sure the communication cables between multiple BMSs are properly connected between Link 1 and Link 0 before starting up.

### Definitions of RJ45 Port PIN

No.	CAN	RS485	RS232
1	---	---	12VDC IN+*
2	GND	---	12VDC IN-*
3	---	---	TX
4	CANH	---	---
5	CANL	---	---
6	---	---	RX
7	---	RS485A	---
8	---	RS485B	GND

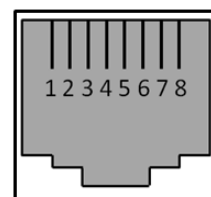

RJ45 Port

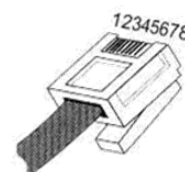

RJ45 Plug

### Wi-Fi

Manufacturer: Pylon Technologies Co., Ltd.

Address: Plant 8, No.505 Kunkai Road, JinXi Town, 215324 Kunshan City, Jiangsu Province, PEOPLE'S REPUBLIC OF CHINA

Importer: XXXX (Located in installed country)

Address: XXXX (Located in installed country)

Basic Information of Wi-Fi	
Wireless Max. Output Power	20dBm
Operating frequency	2412-2472MHz
Gain of antenna	Max 3dBi
Modulation system	DBPSK/DQPSK/CCK(DSSS)
Modulating Repetition	BPSK/QPSK/16QAM/64QAM(OFDM)
Channel spacing	1Mbps/2Mbps/5.5Mbps/11Mbps (DSSS)
Type of antenna	6Mbps/9 Mbps/12 Mbps/18 Mbps/24 Mbps/36 Mbps/48 Mbps/54 Mbps (OFDM)

**NOTE:** For network connection, please scan the QR code below to get Network Connecting Instructions or contact Pylontech service team for further questions.



## Grounding

Grounding point for connecting grounding cable.



### 3.4 System Diagram

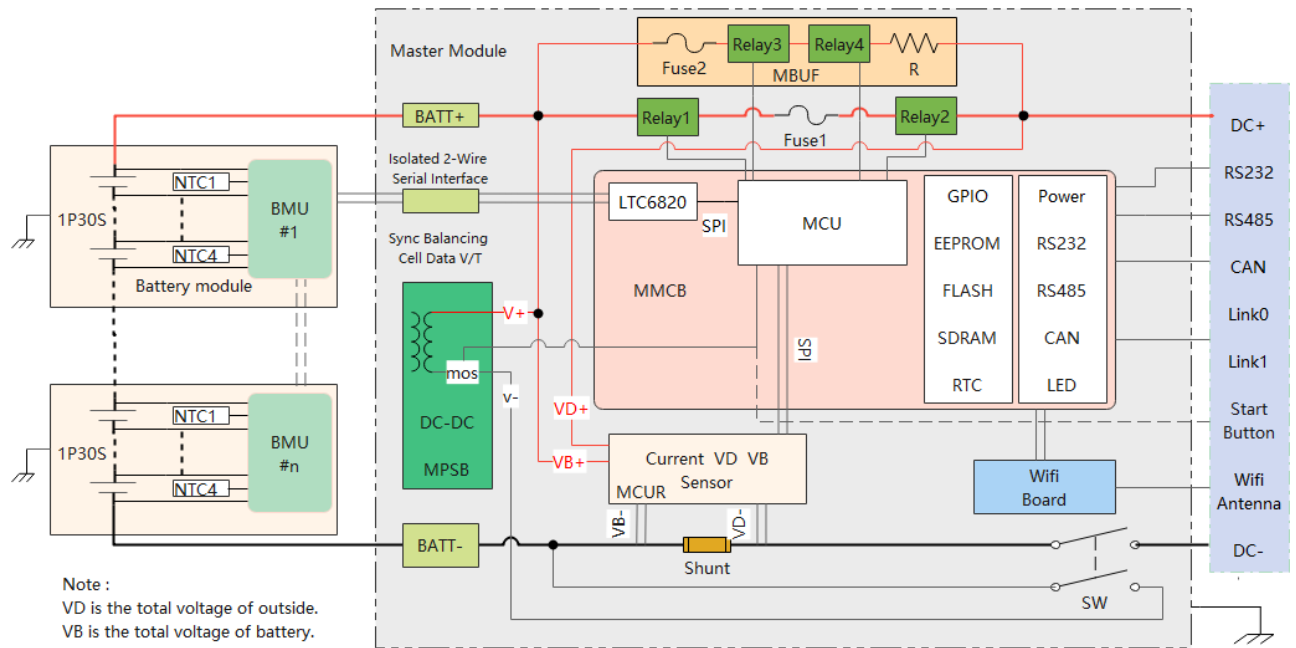

Fig. 3-4: System Diagram

## 4 Installation

Please check every installation step in detail at <Annex 1: Installation and System Turn-on Process List> during the installation.

### 4.1 Checking Before the Installation

#### Checking the Outer Packing and Deliverables

- After receiving the product, check the outer packing for damage, such as holes, cracks, deformation and so on. If any damage is found, contact the local retailer as soon as possible.
- After unpacking the battery, check that the deliverables are complete. If any item is missing or damaged, contact the local retailer as soon as possible.

#### Packing List











<b>FC0500M-40S-V2 Battery Controller</b>		<b>Qty.</b>
1	FC0500M-40S-V2 Battery Controller	1
2	Force-H2 basement	1
3	EPE foam	2
4	3 meters black external communication cable (RJ45)	2
5	1.5 meters black internal communication cable (RJ45)	1
6	3 meters DC+ red external power cable (8AWG)	1
7	3 meters DC- black external power cable (8AWG)	1
8	1 meter yellow-green grounding cable (10AWG)	1
9	M4 screws for fixing brackets	16
10	M8 bolts for fixing basement	6
11	M6 screws for fixing ground cable	1
12	Product Manual	1
13	Warranty card	1
14	Qualified Certificate Card	1
15	Communication protocol setup manual	1
16	374 mm bracket	2
17	622 mm bracket	4
18	Anti-Toppling Bracket	2
19	Dismantle tool	1
20	Waterproof communication port	3
21	Moisture-proof desiccant	1
<b>FH9637M Battery Module</b>		
1	FH9637M battery module	1
2	EPE foam	2
3	Qualified Certificate Card	1
4	Moisture-proof desiccant	1

**NOTE:** For details about actual deliverables, see the Packing List in the packing case.

No additional kits needed for Force-H2-V2 installation.

## 4.2 Preparing tools and instruments

### Tools and Instruments

Type	Tools and Instruments		
Installation	 <p>Wire Cutter</p>	 <p>Crimping Modular Plier</p>	 <p>Cable Ties</p>
	 <p>Screwdriver Set</p>	 <p>Electric Screwdriver</p>	 <p>1000VDC Multimeter</p>
	 <p>Adjustable Wrench</p>	 <p>Sleeve Piece</p>	
Personal protective equipment (PPE)	 <p>Insulated gloves</p>	 <p>Safety goggles</p>	 <p>Safety shoes</p>

**NOTE:** Use properly insulated tools to prevent accidental electric shock or short circuits. If insulated tools are not available, cover the entire exposed metal surfaces with available insulated alternatives, except their tips, with electrical tape.

## 4.3 Selecting the Installation Sites

### 4.3.1 Working Environment Requirements

#### Cleaning

 **DANGER**

**Danger:** Before installation and system power on, the dust and iron scurf must be removed to keep a clean environment.

The system cannot be installed in desert area without an enclosure to prevent from sand.

 **DANGER**

**Danger:** Battery module has active DC power at terminals all the time. Be careful to handle the modules.

#### Temperature

The system working temperature range:  $-10^{\circ}\text{C}\sim 55^{\circ}\text{C}$  ; Optimum temperature:  $18^{\circ}\text{C}\sim 28^{\circ}\text{C}$ .

There are no mandatory ventilation requirements for battery module, but please avoid of installation in confined area. The aeration shall avoid high salinity, humidity or temperature.

**DO NOT** expose the battery system to direct sun light. It is suggested to build sunshade equipment.

 **CAUTION**

**Caution:** The IP rating of Force-H2-V2 system is IP55. But please avoid frost or direct sunlight. Out of the working temperature range will cause the battery system high / low temperature alarm or protection which will further lead to the cycle life reduction. According to the environment requirements, a cooling system or heating system should be installed when necessary.

#### Fire-extinguisher System

 **DANGER**

**Danger:** The fire-extinguisher system must be equipped for safety purpose. The fire system needs to be checked regularly to ensure a normal working status. Regarding to the using and maintenance requirements, please follow local fire equipment guidance.

## Grounding System



**Danger:** Before the battery installation, ensure that the grounding point of the base is stable and reliable. If the battery system is installed in an independent equipment cabin (e.g. container), the grounding of the cabin must be stable and reliable.

The resistance of the grounding system must be  $\leq 100 \text{ m}\Omega$ .

## Clearance

Minimum clearance to heat source shall be more than 2 meters.

Minimum clearance between battery strings shall be more than 0.3 meters.

### 4.3.2 Installation Space Requirements

**⚠ WARNING**

**Warning:** The power terminals of this system have high DC voltage. It must be installed in a restricted access area.

Force-H2-V2 system must not be immersed in water. The battery base cannot be exposed to rain or other water sources. As a suggestion, the base's height shall be >300 mm above the ground.

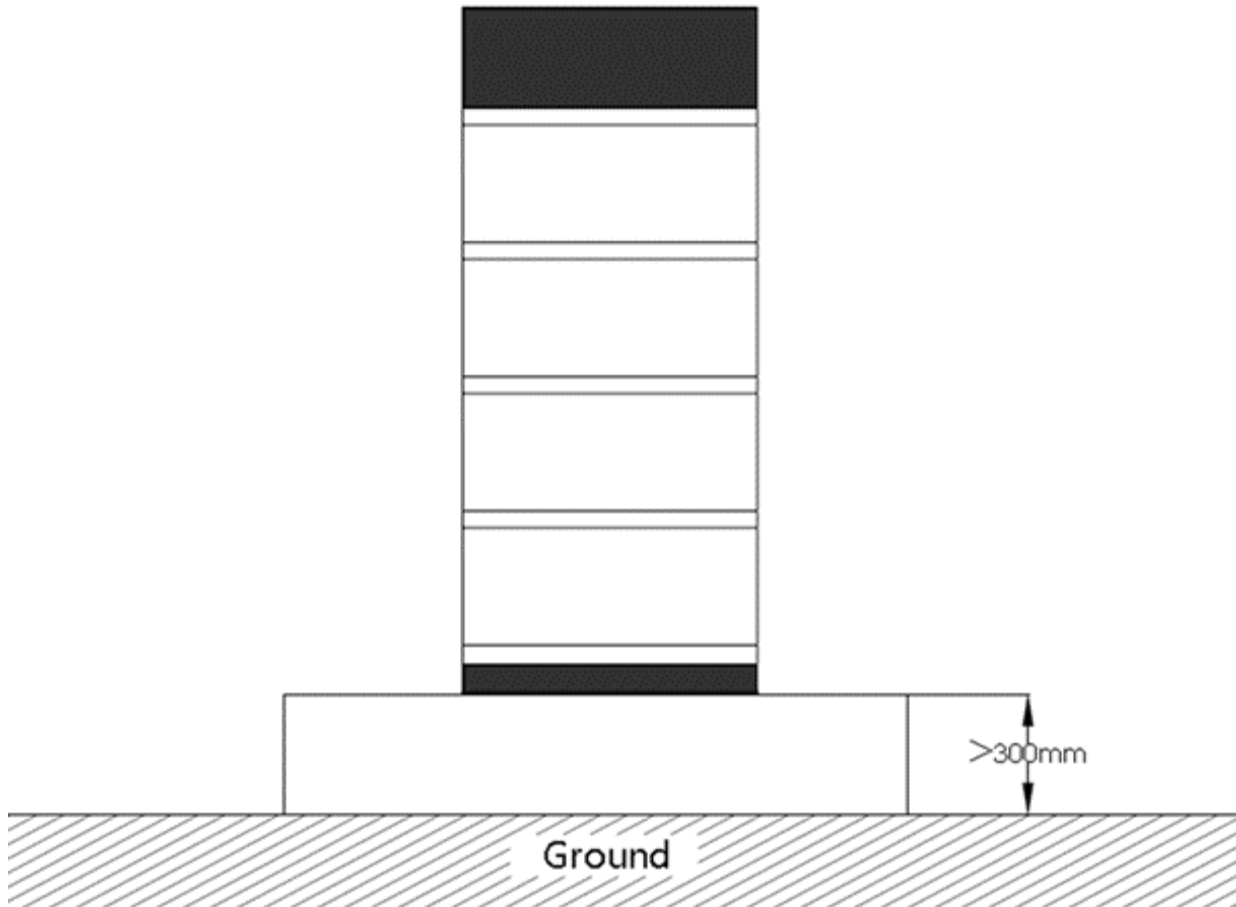

### 4.3.3 Installation Foundation Requirements

The support surface should have sufficient load capacity to support the weight of whole battery system (50~190 kg).

The system must be installed on a fixed and flat support surface.

## 4.4 System Installation

### DANGER

**Danger:** The system is a high voltage DC system, operated by qualified and authorized person only.

### 4.4.1 Mounting the Battery Bottom Base

The weight of the base is light, which a single person can handle with.

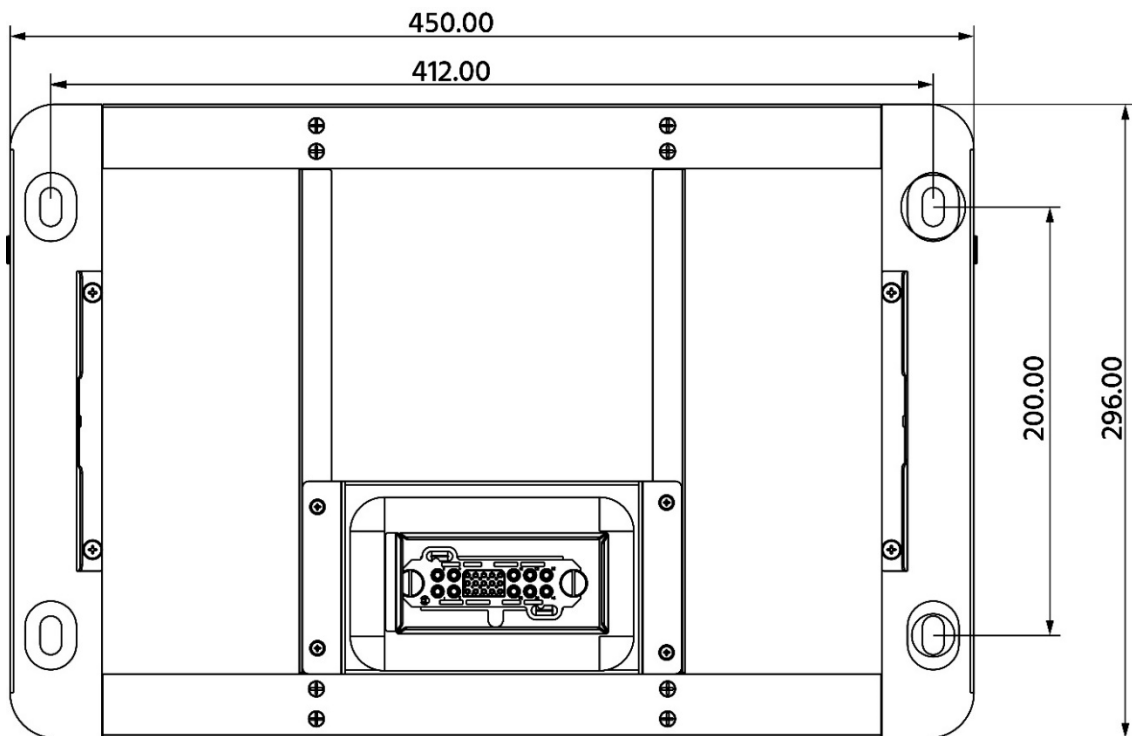

Fig. 4-1: Drawing of bottom base holes' position (unit: mm)

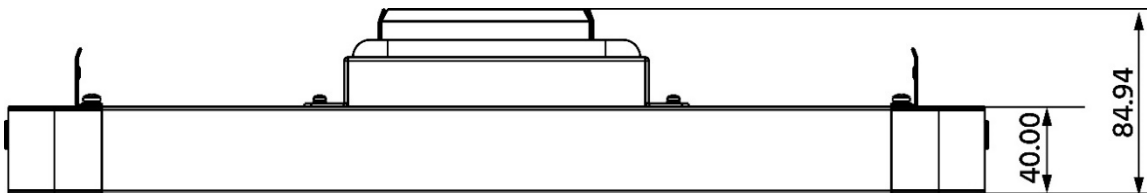

Fig. 4-2: Profile drawing of bottom base (unit: mm)

#### 4.4.2 Battery Modules and Control Module (BMS) Pile up

1. Reach into the grooves on both sides of the battery module and lift the battery module slightly.
2. Adjust to keep the connector of the battery (circled in red) align with the connector of the bottom base (circled in red). Slowly put down the battery, fitting it properly onto the base.

**⚠ WARNING**

**Warning:** If putting hands under the groove, you may get hurt.

**⚠ DANGER**

**Danger:** When battery is connected together with the base, the internal socket still has high voltage DC power from serial connected battery modules (battery module can't be turned off).

3. After installation of the battery module, lift the control module (BMS), adjusting to make its connector align with the connector of the battery module.

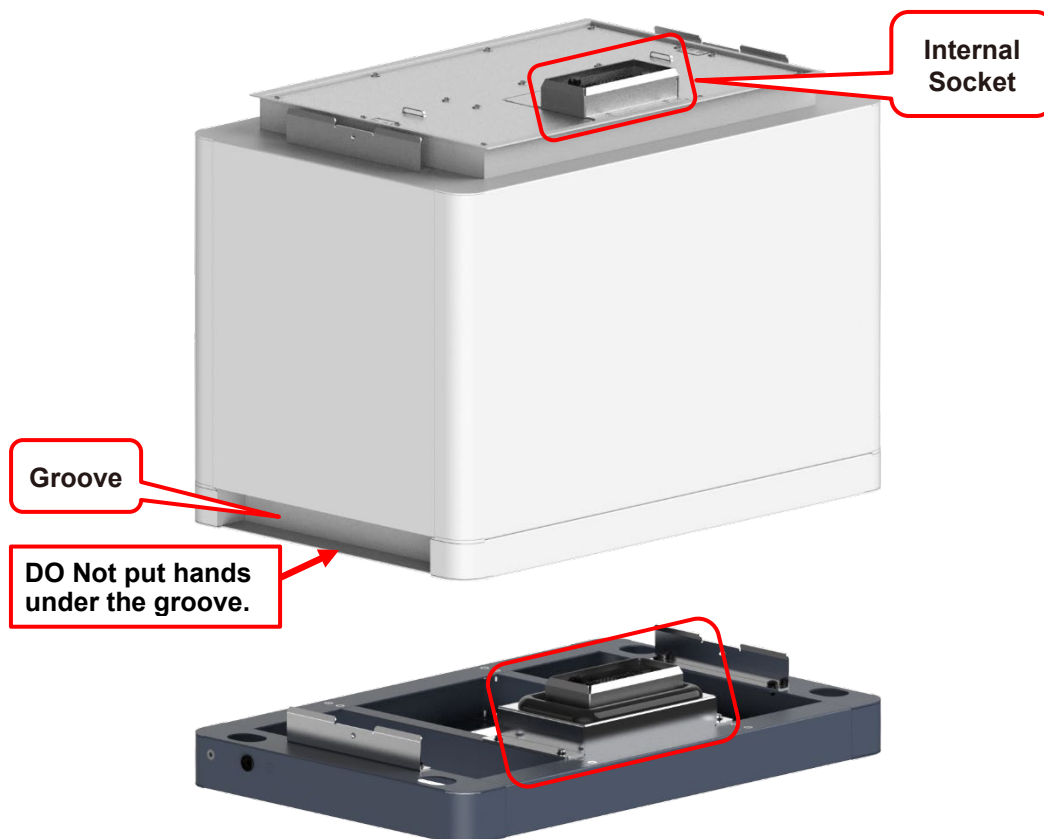

4. Slowly place down the control module (BMS) on the installed battery module.

**NOTE:** Maximum 5 battery modules are allowed to be installed in one string.



### 4.4.3 Installing the Metal Brackets for the System

In control module's package, there are 2 pcs short and 2 pcs long metal brackets.

Fix these metal brackets at both back sides of the battery modules (see the illustration on the right).

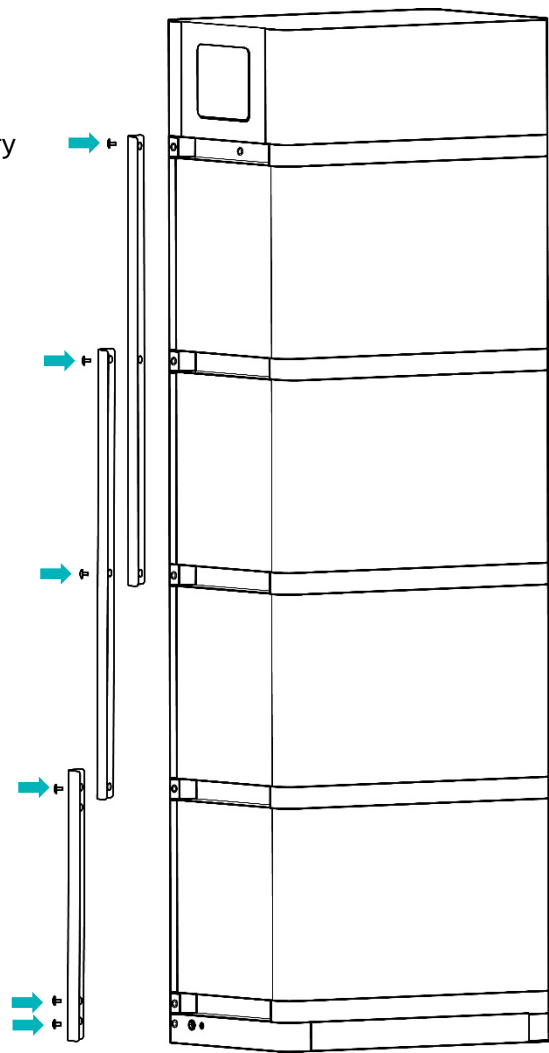

Please follow the illustrations below to install the metal brackets for your practical system.

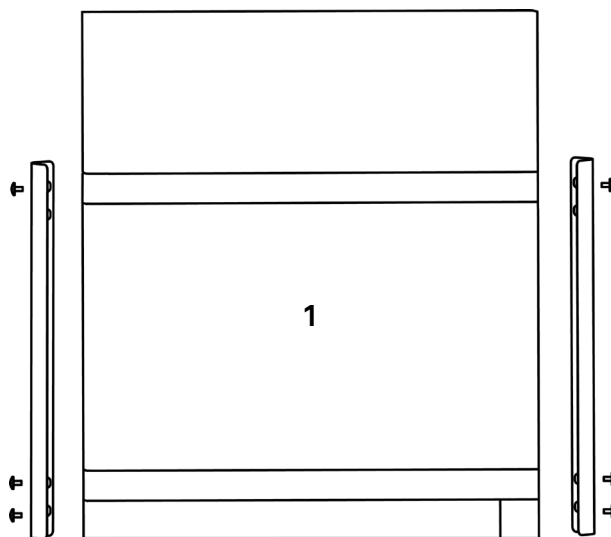

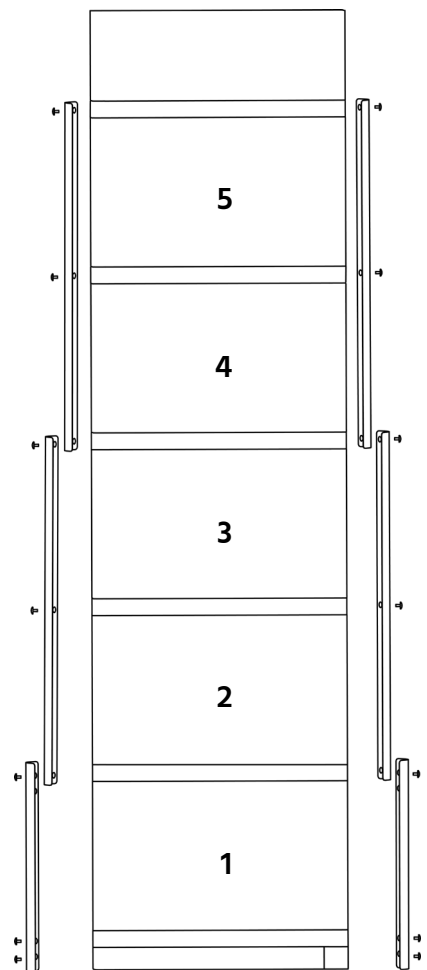
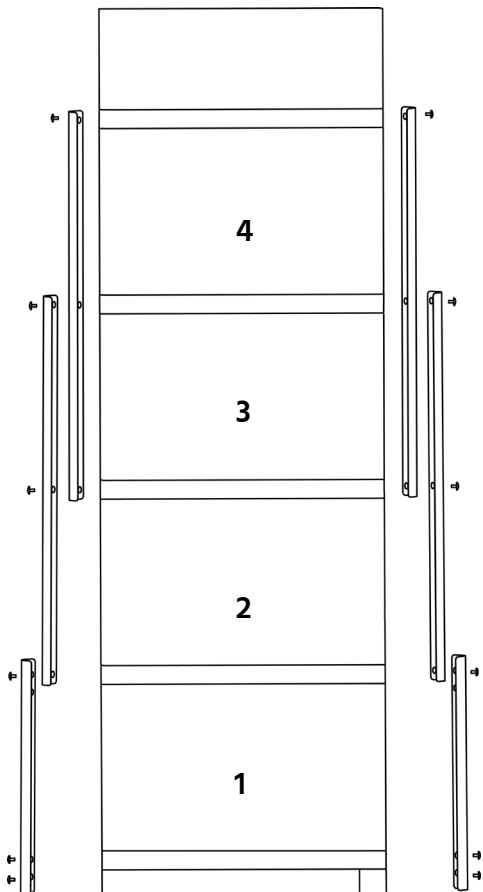
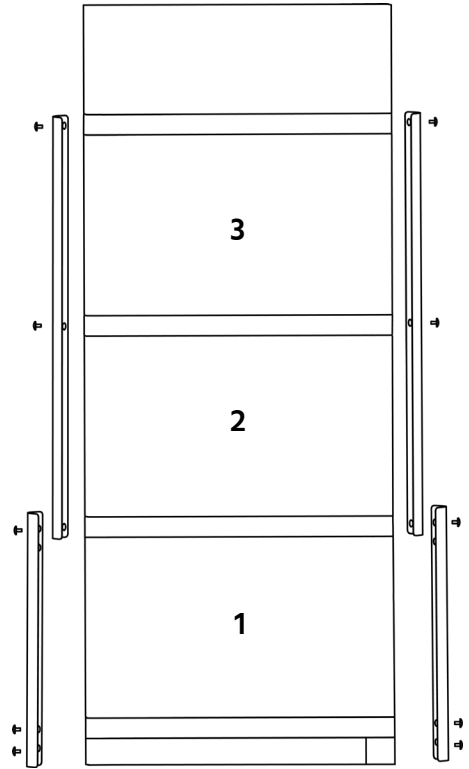
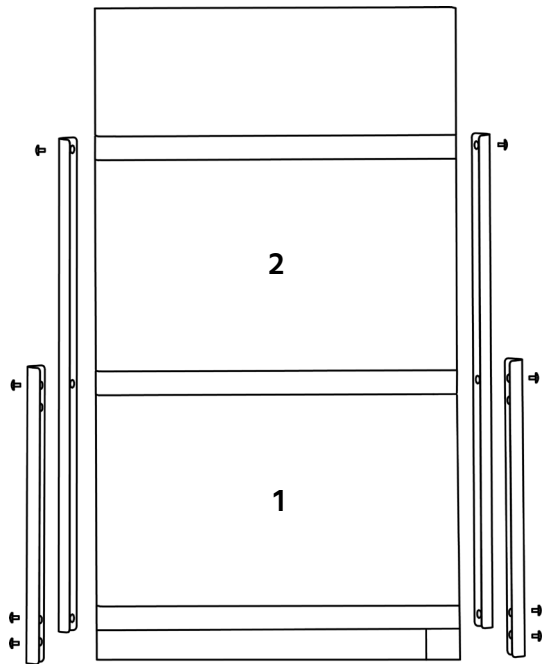

#### 4.4.4 Fixing Screws on the Display Panel and Interface Panel of the Control Module

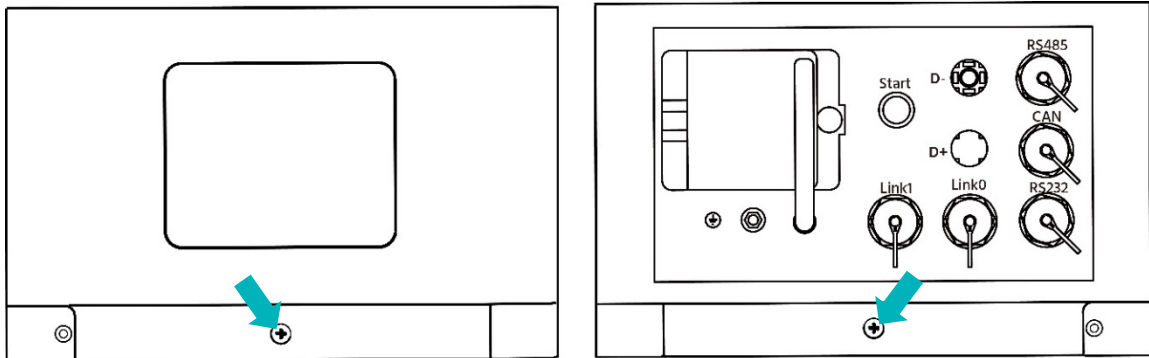

#### 4.4.5 Installing the Anti-Topping Brackets for the System

Force-H2-V2 system is equipped with two anti-topping brackets as follows.



Such brackets act as an alternative of ground mounting of the battery system. Customers can choose either of the following methods for the system installation:

- Ground mounting with 4 x M8 expansion bolts to the support surface (see *section 4.4.1*).
- Bracket mounting with 2 x M8 expansion bolts to the wall (Battery system still needs to be placed on the support surface for supporting the overall weight.)

As long as the installation area meets the requirement of the installation site (see *section 4.3*), in either case the installation stability is guaranteed.

The detailed installation process with such brackets are as follows:

1. Put the base along the wall and reserve 40 mm distance between back of the base and the wall.

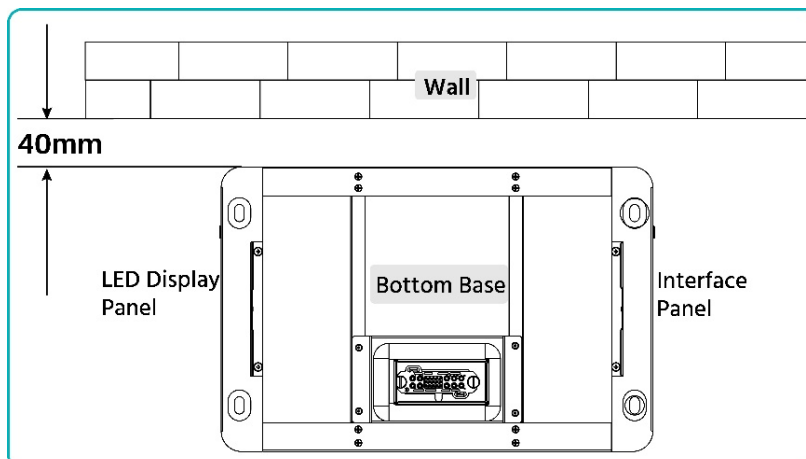

2. Follow the steps described above correctly to install all the battery modules, BMS and brackets, referring to *section 4.4.2, 4.4.3 and 4.4.4*.

**NOTE:** When installing the metal brackets at the back side, ALWAYS remain the two connecting points between brackets and BMS unlocked shown as below.

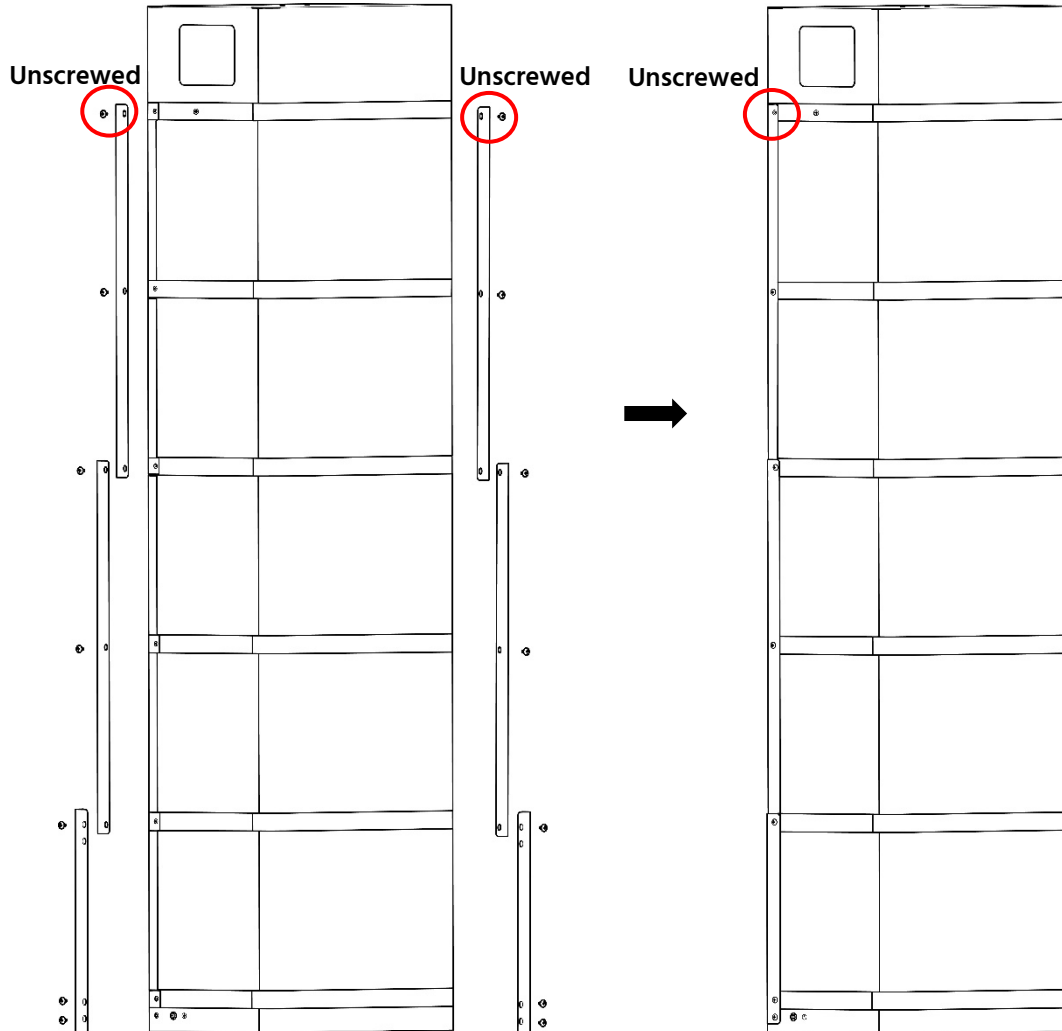

3. Follow the illustrations below, firstly fit the anti-toppling brackets on back sides of the BMS, then use M4 screws to fix.

**REMEMBER** to fit the brackets on both sides of BMS, same with following steps:

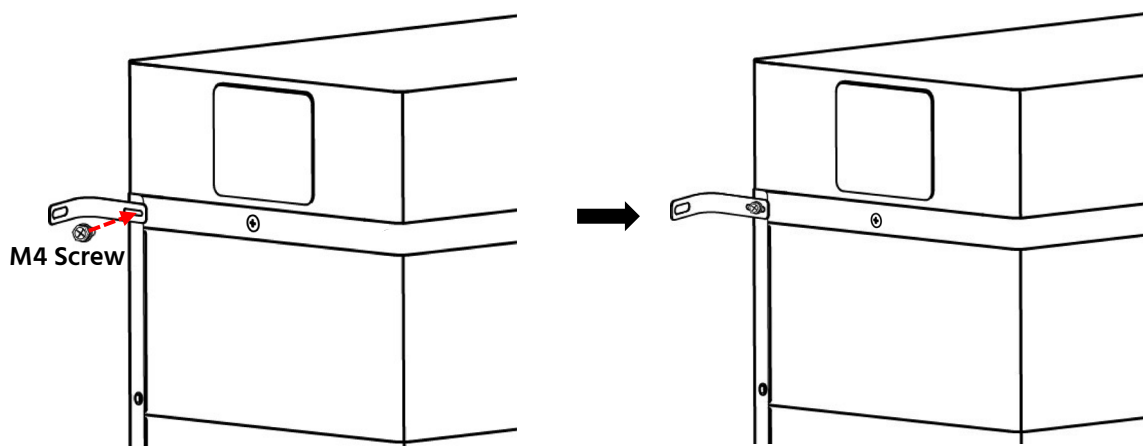

4. Mark the central points of the slotted holes at both sides on the wall.

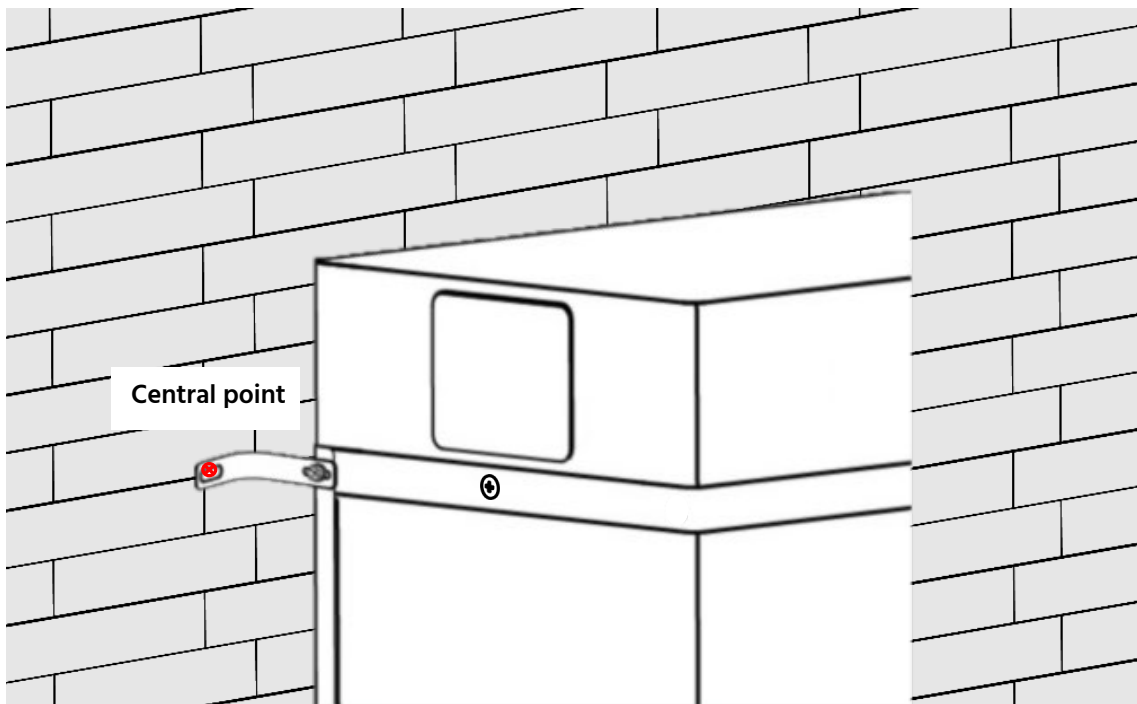

5. Dismantle the brackets on both sides. Aligning the central points, drill two holes ( $\geq 60\text{mm}$  depth) in the wall with a drilling tool and clean the holes.

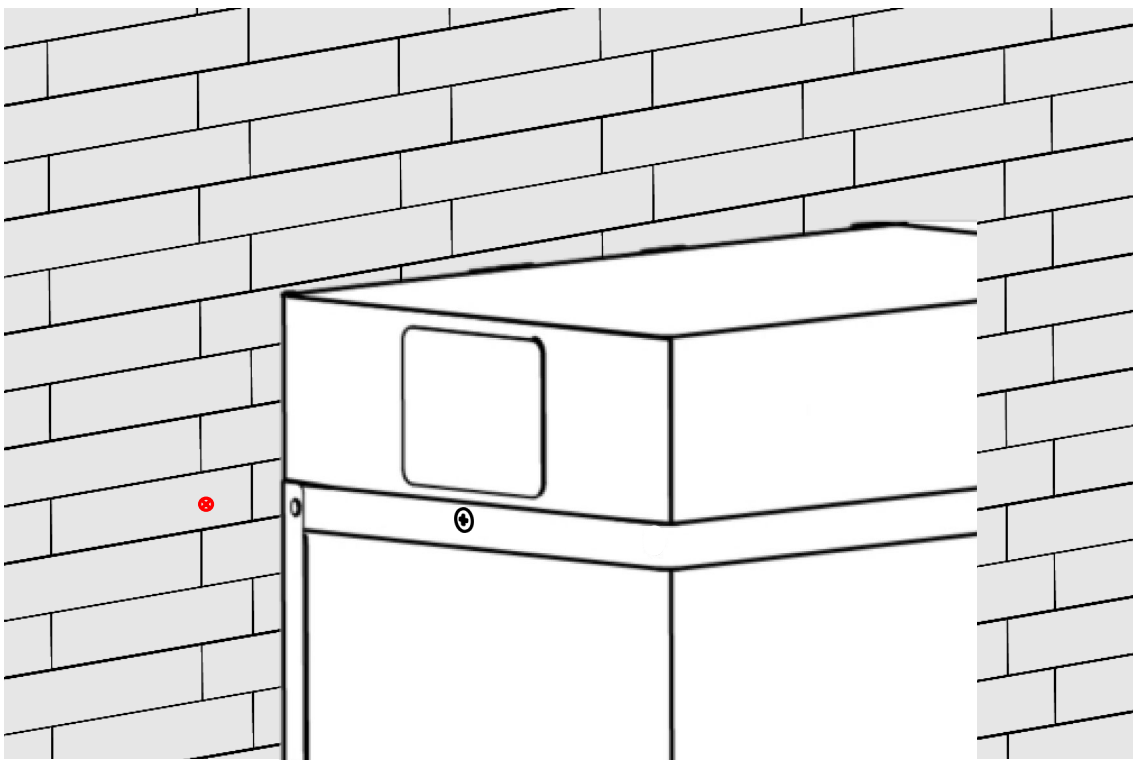

6. Embed the two M8 expansion bolts into the holes respectively.

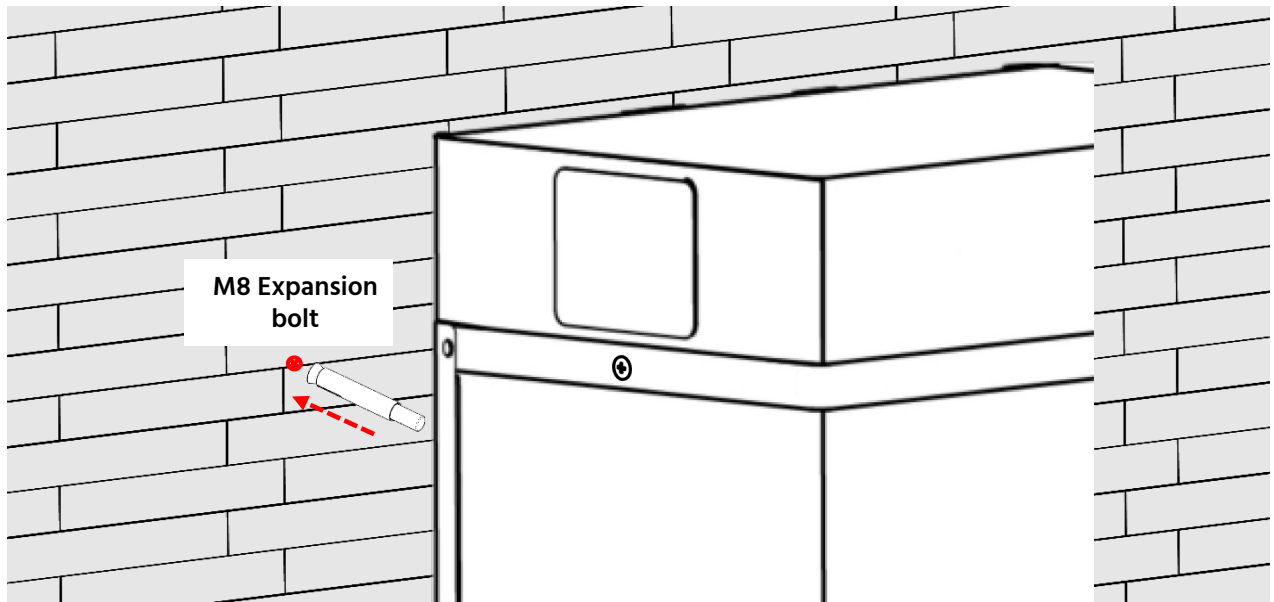

7. Fit the brackets across the M8 expansion bolts on both sides, then fix the brackets on the BMS with M4 screws.

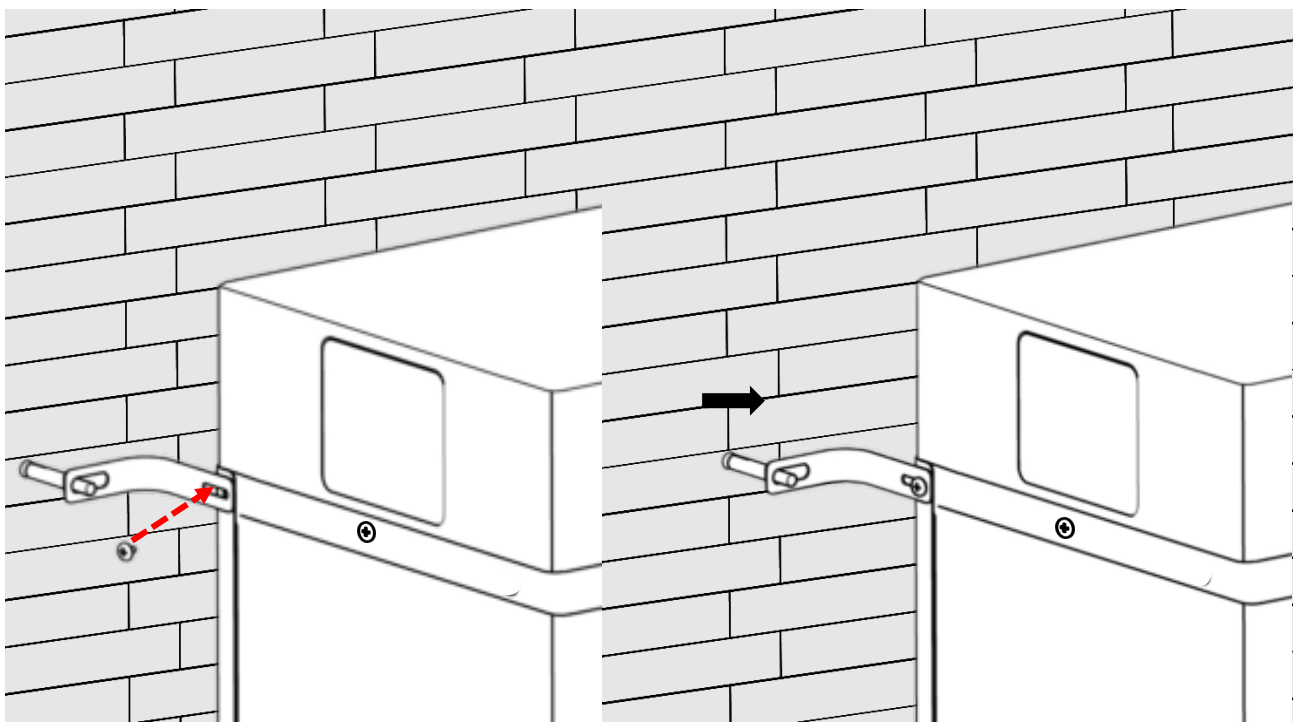

8. Fix the M8 nut (a) across the 8 mm flat gasket (c) and spring washer (b), with 12~13 N.m torque. Repeat this step for the other bracket.

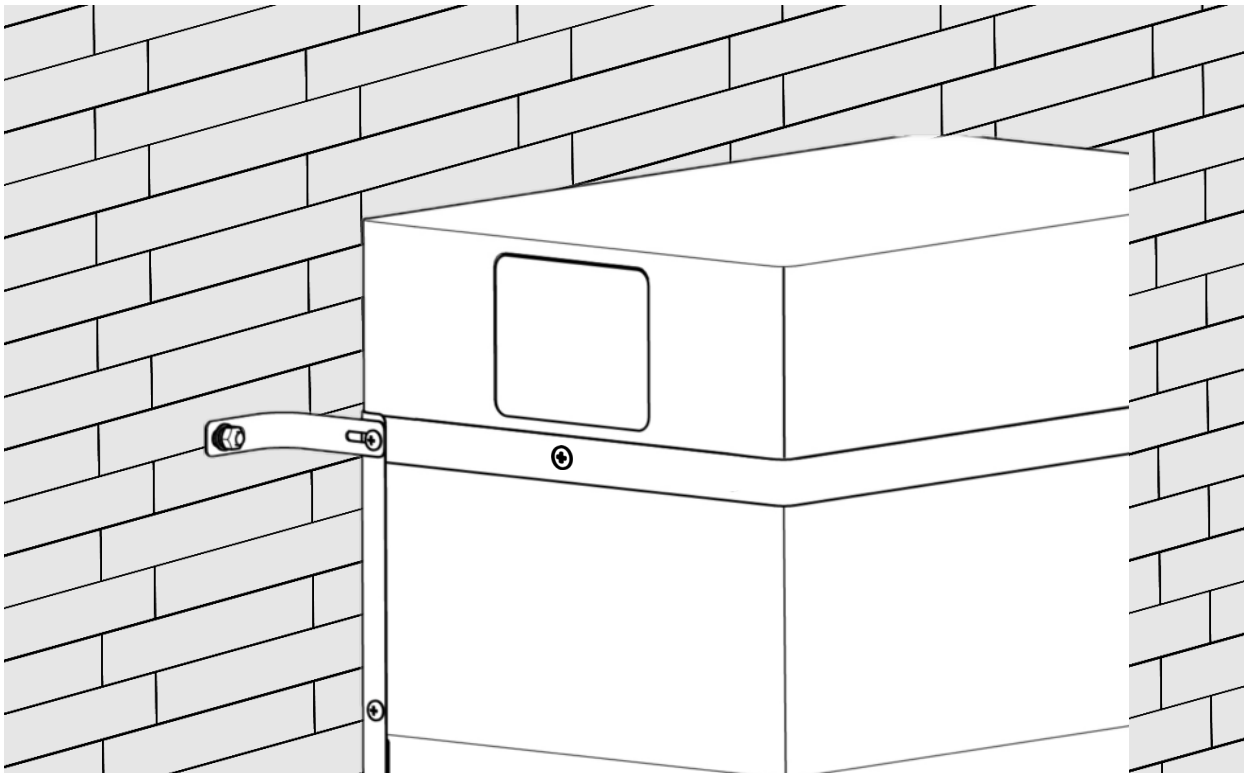
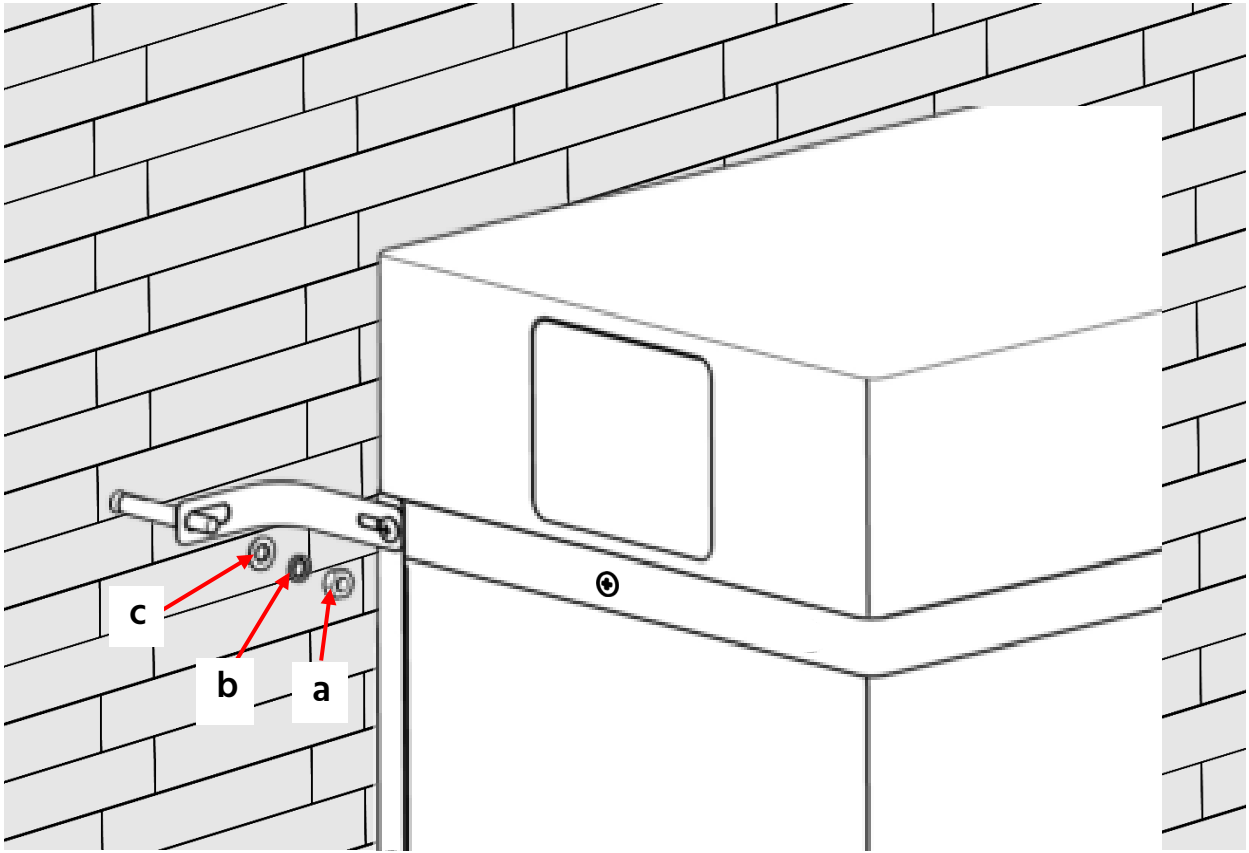

# 5 Cable Connection

**⚠ DANGER**

**Danger:** The battery system is high voltage DC system. Ensure that the grounding of the system is stable and reliable.

**⚠ DANGER**

**Danger:** No short circuit or reserved connection of the battery system’s positive and negative ports.

**⚠ CAUTION**

**Caution:** Wrong communication cables connection will cause the battery system failure.

## 5.1 Checking cables

**⚠ CAUTION**

**Caution:** Power cables use water-proofed connectors. To disconnect, it is required to use a special tool (in the accessory bag), shown as the picture. Do not pull out the cables directly.



**NOTE:** Communication cable uses RJ45 connector and water-proof cover (M19-RJ45) which matches with the communication port on the control module.

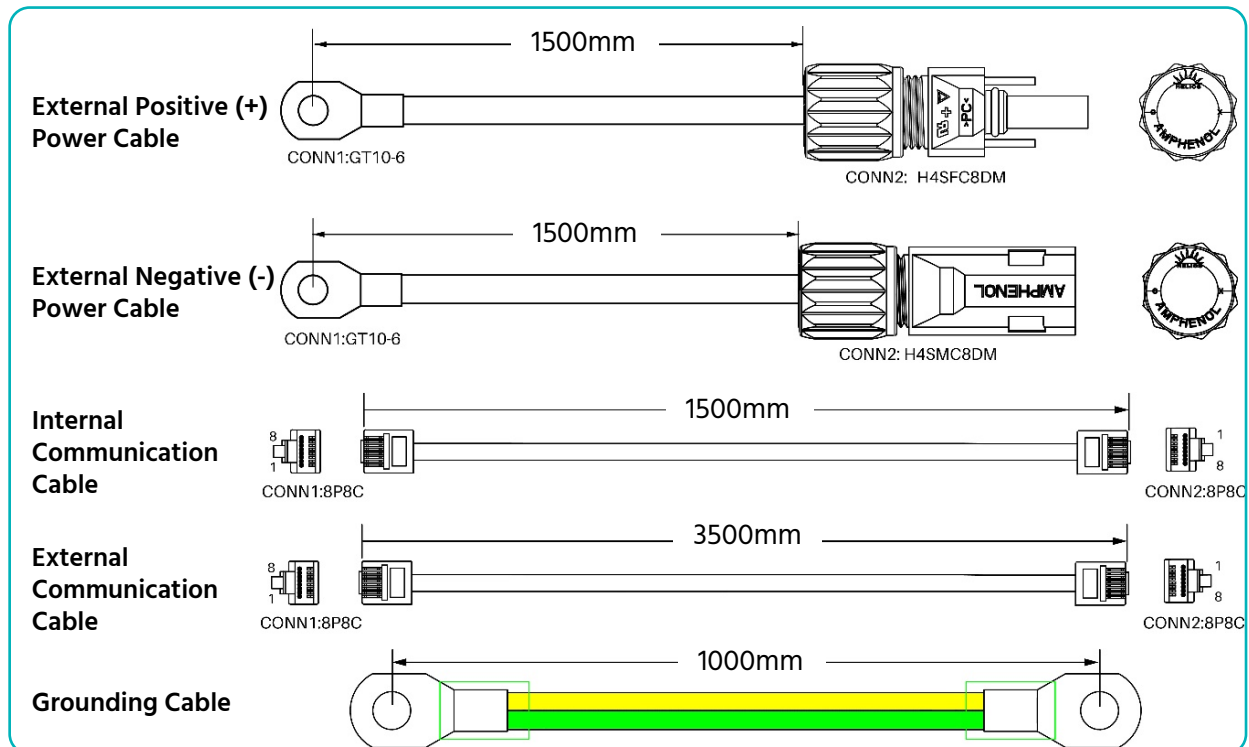
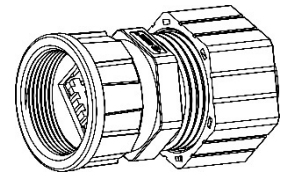



## 5.2 Grounding

**⚠ WARNING**

**Warning:** The Force-H2-V2 modules has 3 grounding points as follows. Grounding cable must be  $\geq 10$  AWG. The cable shall be copper with yellow-green color.

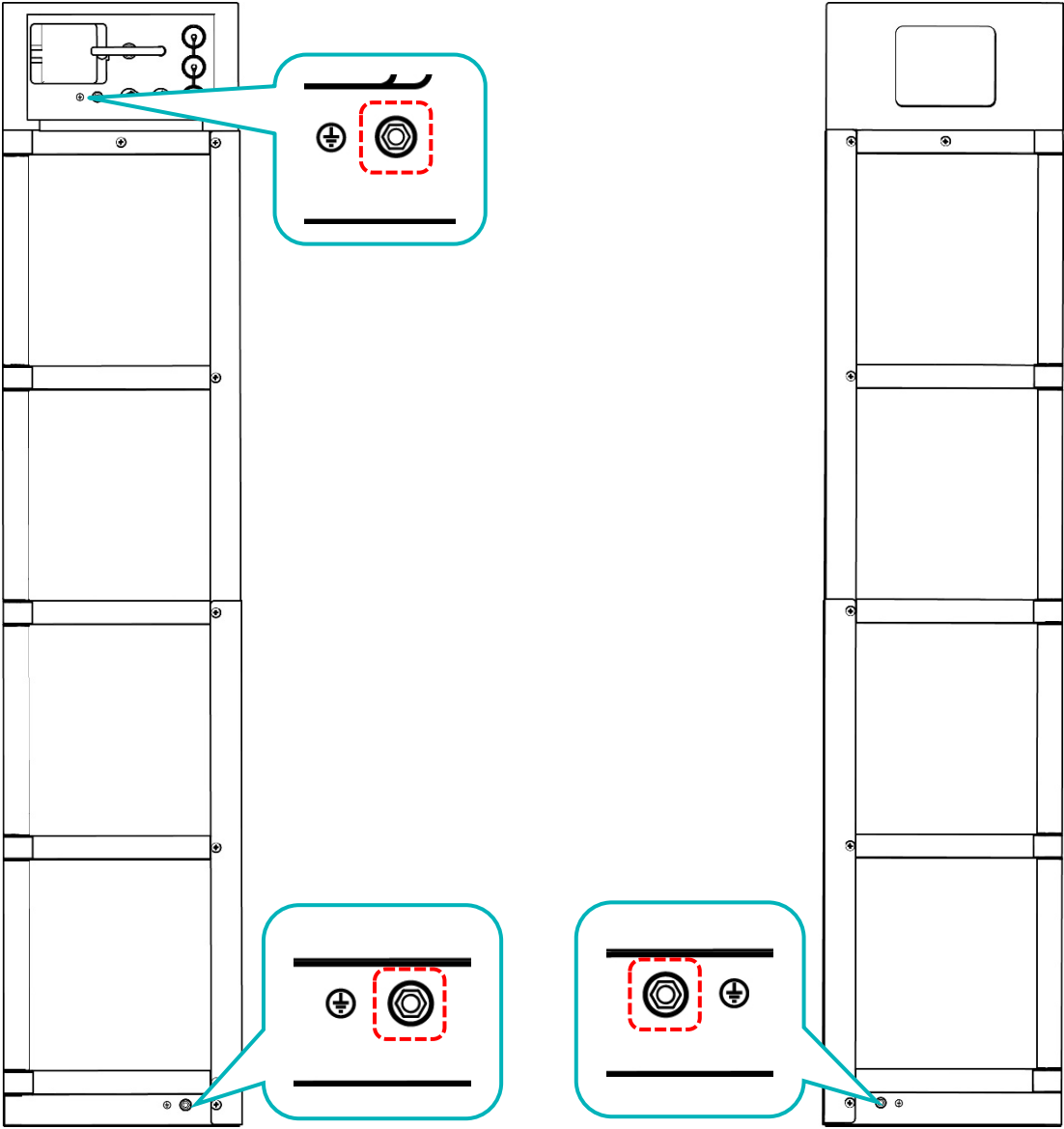

## 5.3 Multi-string Cable Connections

### 5.3.1 Electrical Wiring

#### A. Wiring diagram of 3 strings` system (String quantity $\leq 3$ )

It is suggested to use P-Combiner-HV-3-V2 for up to 3 strings, maximum 50Amps continuous operation.

**NOTE:** DO NOT use P-Combiner-HV-3-V2 or similar concept of multi-strings connection method in case the multiple battery strings need to be operated independently.

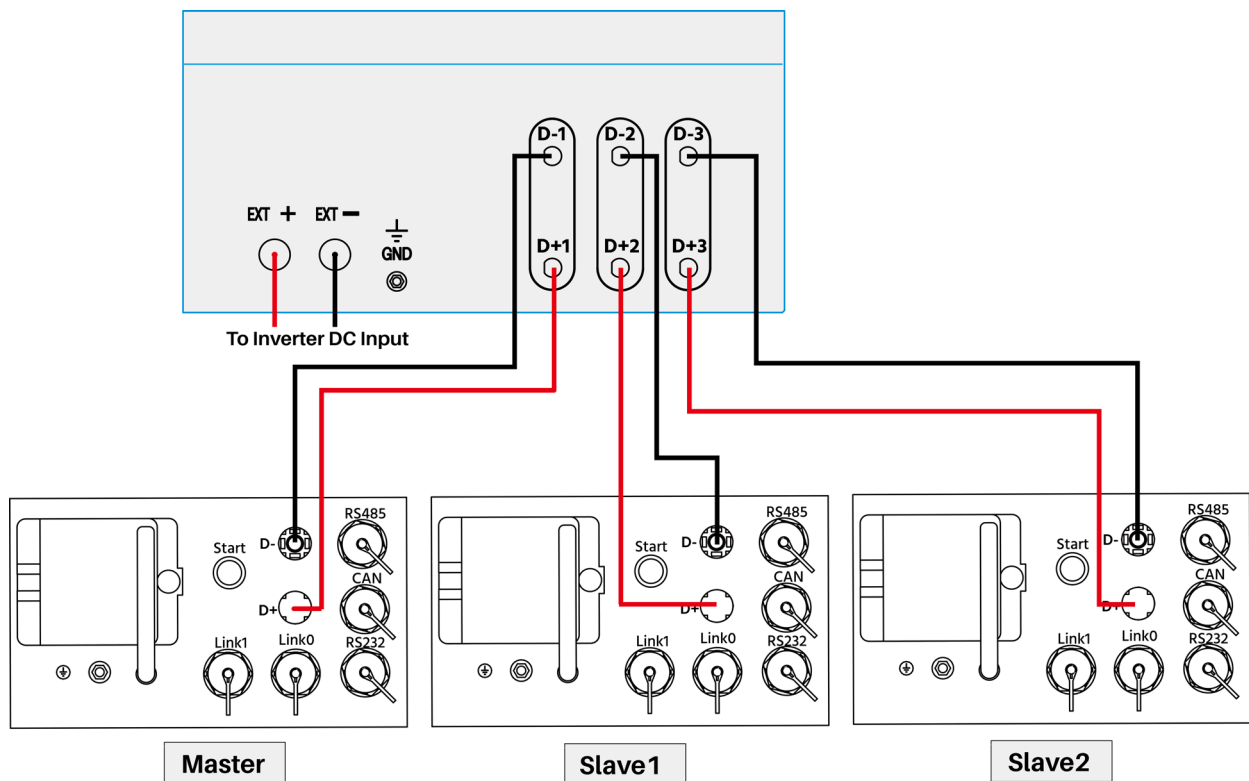

Positive (+) power cable ————

Negative (-) power cable ————

**NOTE:** Make sure to have the D+ & D- plugs into the combiner box properly.

## B. Wiring diagram of multi strings' system ( $3 < \text{String quantity} \leq 6$ )

It is suggested to use P-Combiner-HV-6-V2 for up to 6 strings, maximum 100 Amps continuous operation.

**NOTE:** DO NOT use P-Combiner-HV-6-V2 or similar concept of multi-strings connection method in case the multiple battery strings need to be operated independently.

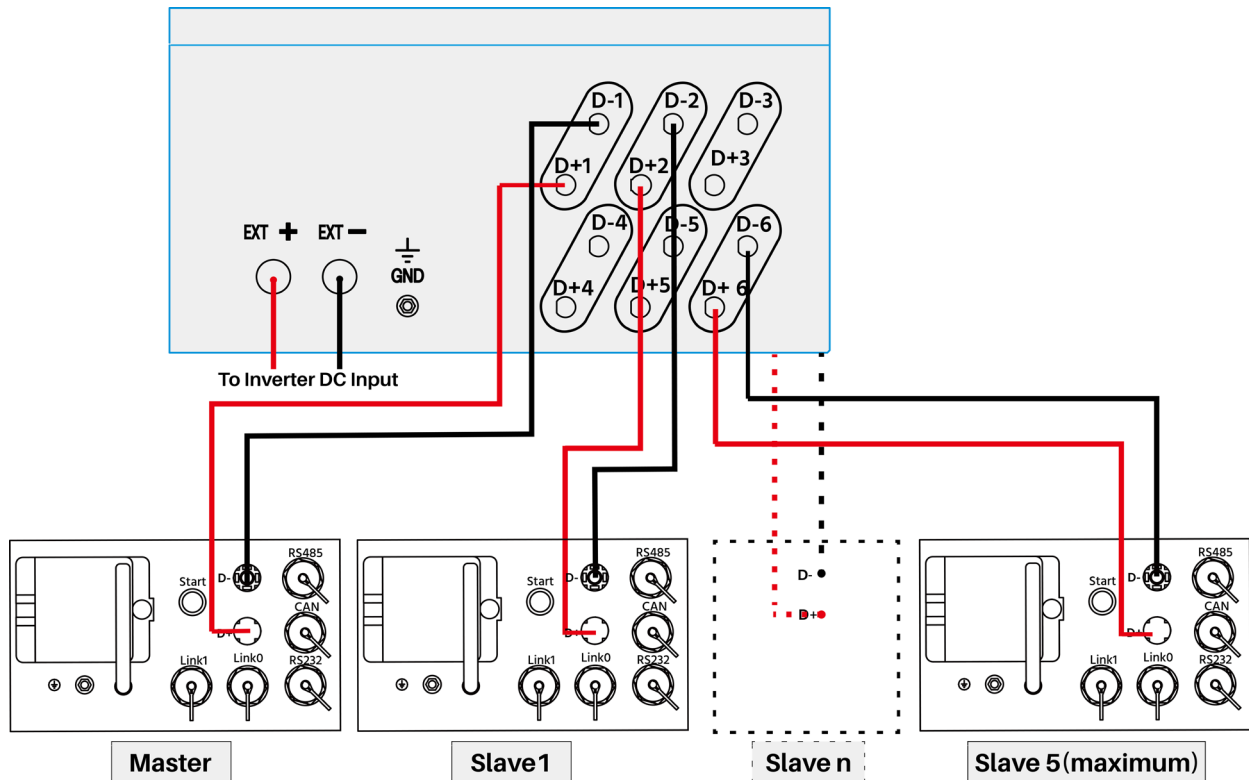

Positive (+) power cable ————  
 Negative (-) power cable ————

**NOTE:** Make sure to have the D+ & D- plugs into the combiner box properly.

### 5.3.2 Communication Cable Connections of Master and Slave Battery Strings

The communication for master/slave string connection shall use an 8 pin pin-pin RJ45 cable, connecting from the first BMS Link 1 to the second BMS Link 0, then from the second BMS Link 1 to third BMS link 0(if has), all the way to the last BMS Link 0.

The BMS with Link Port 0 EMPTY is defined as the Master string. Select either CAN or RS485 on the master string for further connection with the inverter or upper controller.

The CAN/RS485 Port of the slave string is ineffective in this case. Please see the following diagram for communication cable connection.

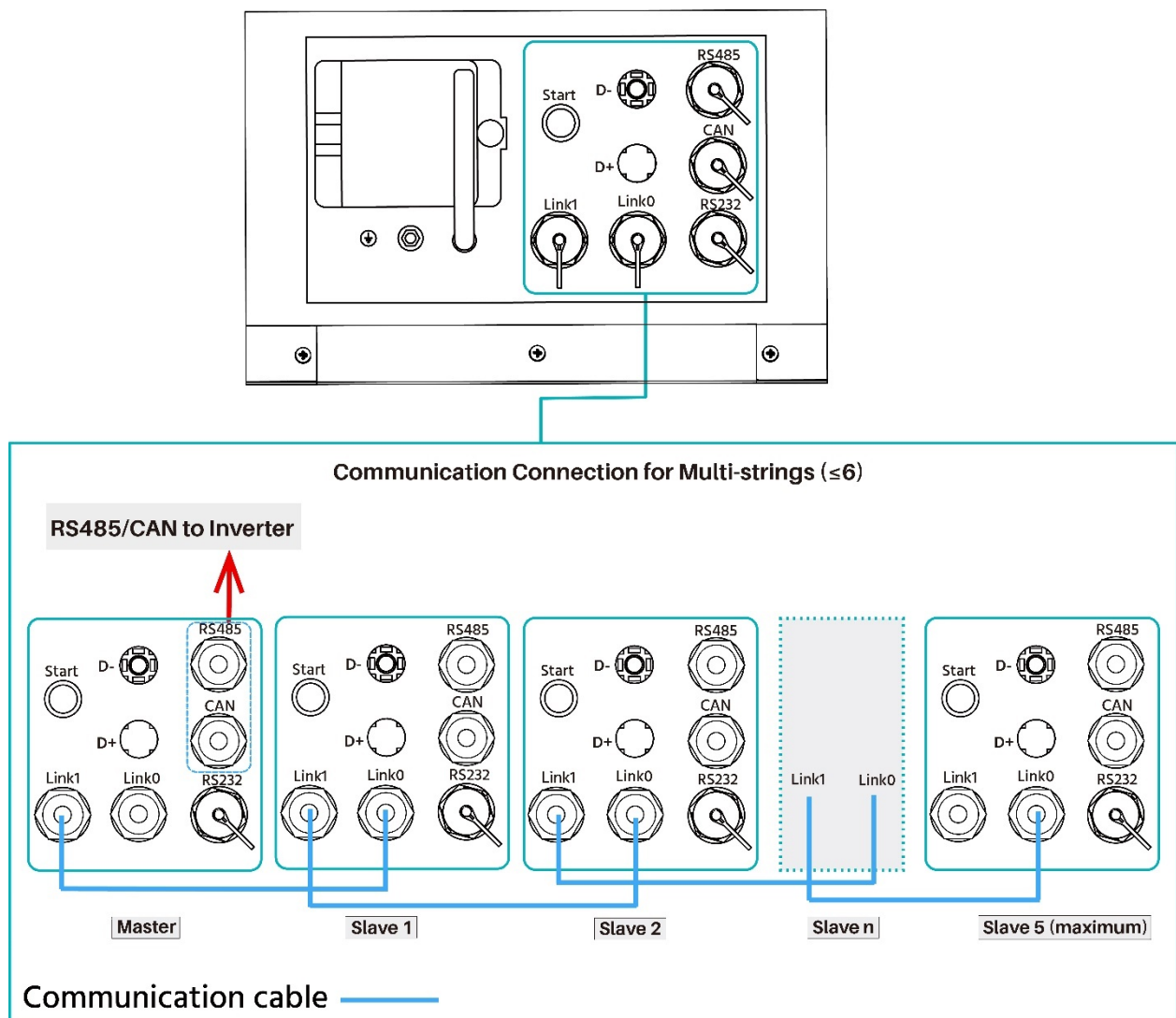

**NOTE:** After installation, DO NOT forget to register online for full warranty:

[www.pylontech.com.cn/service/support](http://www.pylontech.com.cn/service/support)

## 6 Commissioning

### 6.1 System Turning On

#### 6.1.1 Single String System Turning On

##### **WARNING**



**Warning:** Double check all the power cables and communication cables. Ensure that the voltage of the inverter/PCS matches the voltage of the battery system. Check that all the power switches are OFF.

##### **Procedure:**

1. Check that the grounding cable is connected.
2. Check that all the cables are connected correctly.
3. If necessary, turn on the switch for battery on the inverter or the switch between inverter and battery system. If possible, turn on AC or PV power source to wake up the inverter.
4. Open the protection cover of Power Switch on the control module (BMS). And turn on Power Switch.
5. Press Start Button for at least 5 seconds or until buzzer rings. Battery takes 10-30 seconds for self-checking.

If the inverter is powered by AC or PV source, most types of inverters can set up communication with BMS automatically, in this case, the BMS will close relay and system is ready for work.

If after 30 seconds' self-checking, the LED becomes as follows, this means the inverter needs to be powered on by the battery energy:

 <b>Status: Orange, solid</b>	 <b>SOC: Blue, Solid</b>
--	--

In this case, press the Start Button for at least 10 seconds, till the Status LED lighting Blue and fast flashing. Then the battery will perform black start to support the inverter. After the inverter is started and communication is set, the BMS is ready for work.

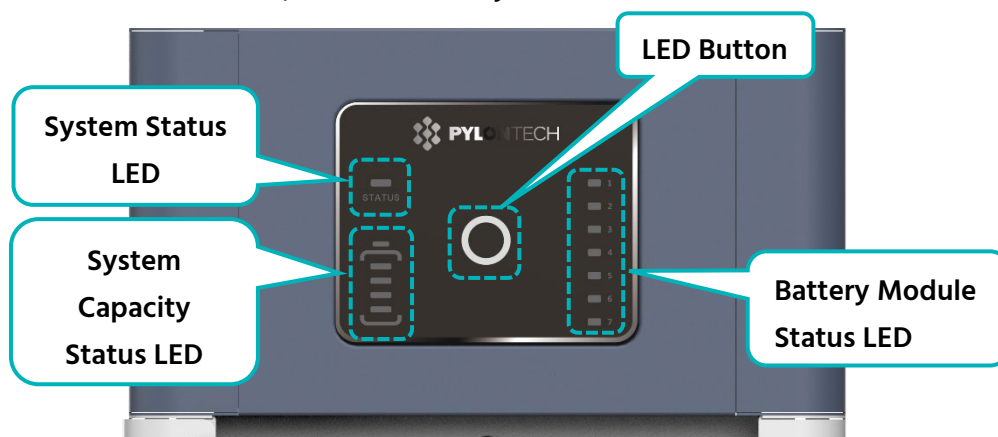

If the battery has been configured to a different communication protocol, please follow LED Long Press 2 guidance in *section 3.3.1*. Make sure to select the correct protocol and restart BMS to enable the communication with inverter.

 **CAUTION**

**Caution:** If the power switch is tripped off due to over current or short circuit, be sure to wait more than 30 minutes, then it can be turned on again; otherwise it may cause damage to the switch.

 **WARNING**

**Warning:** If there is any failure during the self-check process, be sure to debug the failure prior to next step. If the "STATUS" LED shows orange from the beginning, it means there is failure in the battery string. In this case, the Power Relays in BMS will open, and debugging must be done first.

**NOTE:** The LED lamp will be off in 20 seconds without any operation.

 **CAUTION**

**Caution:** During the first time starting, the system requires full charge process for SOC calibration purpose.

 **CAUTION**

**Caution:** After long time storage without charging, it is suggested to fully charge the whole Battery Energy Storage System (BESS) prior to installation. Depending on the SOC level, regularly every 6 months' full charge is requested during continuous operation as well. it will be handled automatically by the communication between BESS and external device.

## 6.1.2 Multi-strings System Turning On

### **WARNING**

**Warning:** Double check all the power cables and communication cables. Make sure the voltage of the inverter/PCS matches the voltage of the battery system. Check to make sure all the power switches are OFF.



### **Procedure:**

1. Check that the grounding cable is connected.
2. Check that all cables are connected correctly, especially the Link 1 / Link 0 between master and slave strings.
3. If necessary, turn on the switch for battery on the inverter or the switch between inverter and battery system. If possible, turn on AC or PV power source to wake up the inverter.
4. Open protect cover of power switch. And turn on power switch on the control module (BMS)of all the strings.
5. From the last string, press the start button for at least 5 seconds or until buzzer rings for start-up. Then further turn on each string one by one following the table below, the start-up interval between each string shall be less than 30 seconds:

Communication Structure	Start-up Sequence
Master string	Last Start-up
Slave string 1	5th Start-up
Slave string 2	4th Start-up (if has)
Slave string 3	3rd Start-up (if has)
Slave string 4	2nd Start-up (if has)
Slave string 5	1st Start-up (if has)

6. After all strings start-up, the battery system takes 30 seconds for self-checking. If the inverter is powered by AC or PV source, most types of inverters can set up communication with BMS automatically. In this case, the BMS will close relay and system is ready for work.

If after 30 seconds' self-checking the LED becomes as follows, this means the inverter needs to be powered on by the battery energy:

 <b>Status: Orange, solid</b>	 <b>SOC: Blue, Solid</b>
--	---

In this case, press and hold the Start button for at least 10 seconds, till the Status LED lighting Blue and fast flashing. Then battery will perform black start to support inverter. After the inverter is started and communication is established, the BMS is ready for work.

## 6.2 System Debug

This system debug is for BESS system (Battery Energy Storage System). It must be operated with configured UPS, PCS and EMS system together, which means that the BESS debug cannot be performed alone.

Debug Procedure	Content
Preparations for debug	<p>Turn on the BESS system, referring to <i>section 6.1</i>.</p> <p>DO NOT turn on the load before turning on the whole BESS system.</p> <p><b>NOTE:</b> If the equipment other than the BESS has the turning on procedure of its own system, ensure to follow its operation instructions.</p>
Working together with inverter	<ol style="list-style-type: none"> <li>(1) Check the communication cable connection and make sure the cable order on battery and inverter side are matched. All undefined pins are suggested to be empty.</li> <li>(2) Check the baud rate of inverter. The default value of battery CAN is 500kbps, MODBUS 485 is 9600 bps. If necessary, change the baud rate of RS485.</li> <li>(3) Check that the terminal resistance CAN 120 <math>\Omega</math>, RS485 120 <math>\Omega</math>.</li> <li>(4) If necessary, check the setting on inverter or control box has right parameters and brand of battery. And check the information of BESS shown on inverter is correct.</li> </ol>



## 7 Maintenance

### 7.1 System Turning Off

#### DANGER

**Danger:** When any failure occurs or there is a need for service, the battery storage system must be powered off at first.

#### Procedure

1. Turn off inverter or power supply on DC side.
2. Turn off the switch between PCS and battery system.
3. Turn off the power switch of all BMSs.

#### CAUTION

**Caution:** Before replacing the battery module for service, make sure to charge/discharge the existing battery module voltage similar to the replaced one. Otherwise the system needs long time to do balance for this replaced battery module.

#### CAUTION

**Caution:** When restart is required for any troubleshooting steps, make sure to restart the entire system (every BMS within the system). Please do not only restart partially of the BMS within the system, which will further lead to error.

## 7.2 Battery Maintenance



**Danger:** The maintenance of battery must be done by qualified and authorized person only.



**Danger:** The power must be turned off prior to any maintenance of the battery.

### Voltage Inspection

Check the voltage of battery system through the monitor system. Check if the system is abnormal voltage. For example: Single cell's voltage is abnormally high or low.

### SOC Inspection

Check the SOC of battery system through the monitor system. Check if the battery string is abnormal SOC.

### Cable Inspection

Visual inspect all the cables of battery system. Check if the cables are broken, aging, or getting loose.

### Balancing

The battery strings will become unbalanced if not full charged for a long time. The balancing maintenance (full charged) should be done every 3 months and is usually done automatically by communication between the system and external device.

### Output Relay Inspection

Under low load condition (low current), switch the output relay to OFF and ON to hear the clicking sound, which means this relay can be turned off and on normally.

### History Inspection

Analyze the history records to check if there is an accident (alarm and protection) and analyze the reasons.

### Environment Inspection

Check the installation environment such as dust, water, insect etc. Ensure that it is suitable for IP55 battery system.

### Shutdown and Maintenance

Some battery function must be restarted before ESS maintenance. ESS maintenance shall be done at least once every 6 months.

### 7.3 Troubleshooting



**Danger:** This system is a high voltage DC system, operated by qualified and authorized person only.



**Danger:** Before checking the failure, ensure to check that all the cables connection and the BESS system can be turned on normally.

No	Problem	Possible Reason	Solution
1	No power output, no LED on.	Too short time for pressing Start button.	Press and hold at least 5 seconds to turn on. Press and hold at least 10 seconds for black start.
		The button battery in controller is missing or has failure. The power supply in control module (BMS) has failure.	Change the control module.
		The battery voltage is too low.	Ensure that there are at least 2 battery modules.
		The connector of base has failure, or the base is not connected.	Ensure that the base is in connected properly and change base if necessary.
2	After turning on, Status LED slow flashing orange. Others off.	Self-checking failure. DC side has a voltage, but voltage difference with the battery system is higher than 20 volts.	Ensure that there is no DC voltage or set correct DC voltage before pressing Start button. Follow power on process to turn on.
		BMS internal failure.	Use debug tool/Wi-Fi monitoring to further analysis or change the control module.
3	Status LED fast flashing orange, others off.	The time interval after latest black start is too short.	Wait more than 5 minutes and try black start again.
		The battery system under error condition such as: temperature or current protection or other errors, thus no response to black start.	Ensure that there is no other protection factor. Or use debug tool for further analysis.

No	Problem	Possible Reason	Solution
4	Buzzer ring continues	Relay adhesion or failure.	Completely disconnect battery system with any DC source then make a restart. If problem still exists, then replace the controller.
5	Status LED solid orange.	Communication lost with inverter	Check the communication cable PIN and wiring is correct. Check the inverter communication settings
	Battery module LED blue solid.	Over current protection.	Check DC side. And wait until BMS release protection.
		Control module failure.	Use debug tool for further analysis or change the control module.
6	Status LED solid orange.	Over/ under temperature protection.	Check environment temperature. And wait BMS release.
	Battery module exists LED in orange solid	Over voltage protection.	Check DC charge voltage setting or wait BMS release.
		Under voltage protection.	Perform black start function, and then charge the system.
		Battery module BMS failure	Use debug tool for further analysis or change the battery module.
7	All LED blue but no output.	Fuse fusing	Change the control module
8	Other failure	Cell failure or electrical board failure. Or debug tool is needed for further analysis.	If you still can't debug the failure, please contact with distributor or Pylontech.

Once a certain failure is detected following the trouble shooting procedure, turn off the battery string first before replacement so as to avoid further over discharge to the system due to the self-consumption.

## 7.4 Replacement of main components among the BESS

### DANGER

**Danger:** This system is a high voltage DC system, operated by qualified and authorized person only.

### DANGER

**Danger:** Before replacing the main component, turn off the maintenance battery string's power, and ensure that the D+ and D- terminal are without power. Refer to *chapter 7* for turning off process.

### 7.4.1 Replacement of Battery module

#### Procedure

1. Charge existing module to full (SOC 100%). Make sure new battery module is 100% SOC as well.
2. Turn off the whole battery string's power. Make sure to confirm the D+ and D- terminals are without power. Refer to *section 7.1* for turning off process.
3. Dismantle D+ and D- power cables, communication cable and grounding cable.
4. Dismantle the control module's fixing screws on the interface panel and display panel.

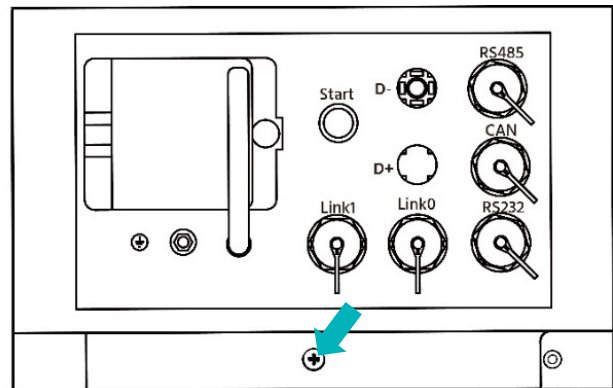
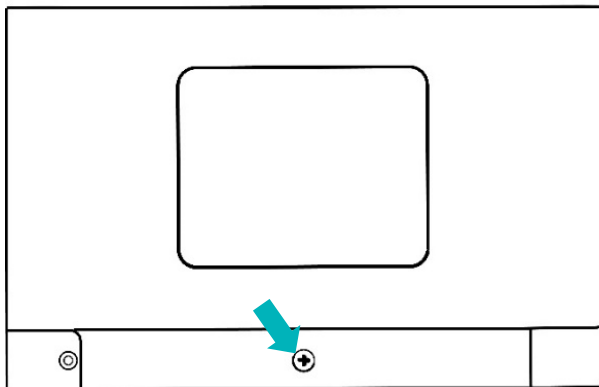

5. Dismantle the metal brackets as follows.

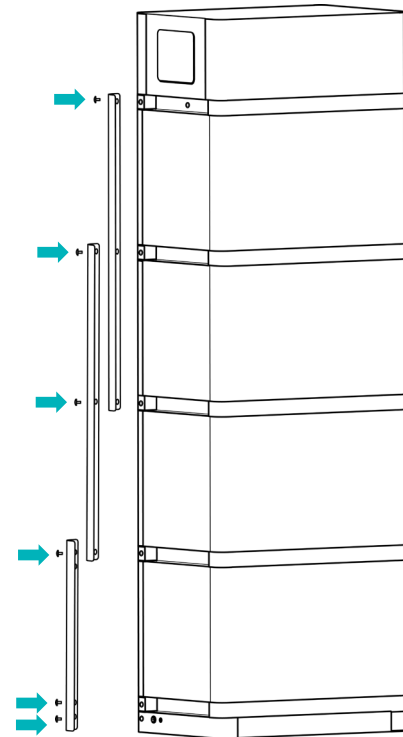

6. Remove the control module and each battery module one by one.

**⚠ DANGER**

**Danger:** When battery is connected together with the base, the internal socket still has high voltage DC power from serial connected battery modules.

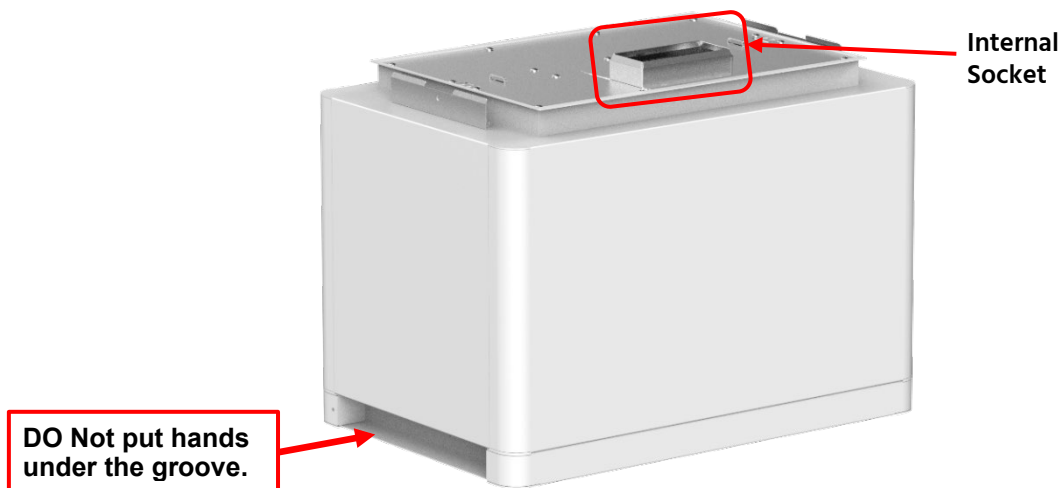

**⚠ WARNING**

**Warning:** If putting hands under the groove, you may get hurt.

7. Pile up the new battery module. And install back the battery modules and control module.
8. Fix back the two screws on the control Module's. And install back the fix metal brackets.
9. Install back grounding cable, communication cable and the D+ and D- power cables.
10. Turn on this battery string, referring to *section 6.1*.

## 7.4.2 Replacement of Control module

### Procedure

1. Turn off the whole battery string's power. Make sure to confirm the D+ and D- terminals are without power. Refer to *section 7.1* for turning off process.
2. Dismantle D+ and D- power cables, communication cable and grounding cable.
3. Dismantle the control module's fix screws on the left and right (same as *section 7.4.1*).
4. Dismantle the metal brackets (same as *section 7.4.1*).
5. Remove the control module.



**Danger:** When battery is connected together with the base, the internal socket still has high voltage DC power from serial connected battery modules. Beware of electric shock.

6. Pile up the new control module.
7. Fix back the screws on the control module's interface panel and display panel. And install back the metal brackets.
8. Install back grounding cable, communication cable and the D+ and D- power cables.
9. Turn on this battery string, referring to *section 6.1*.

## 8 Shipment and Storage

### 8.1 Shipment

Before shipment, single module is pre-charged to about 100% SOC, or according to customer requirements. After delivered on-site, the remaining battery capacity is determined by the storage time and condition.

- The battery modules should meet the UN38.3 certificate standard.
- In particular, local rules and policies (e.g. ADR: European Agreement concerning the International Carriage of Dangerous Goods by Road) for the product transportation shall be complied with. For more details, please enquiry the Safety Data Sheet (SDS) from Pylontech: [service@pylontech.com.cn](mailto:service@pylontech.com.cn).

### 8.2 Storage

For long-term storage, e.g. if it needs to be stored for a long time (more than 6 months), the battery cells are highly suggested to be stored in the temperature range of 5°C~45°C, relative humidity <65% and corrosive-gas-freed environment. It is required to charge them every six months, and the SOC should be no less than 90%.

#### CAUTION

**Caution:** If you do not follow the above instructions for long term storage of the battery, the cycle life will decrease heavily.



## 9 Disposal

In case a battery (normal condition or damaged) needs disposal or needs recycling, it shall follow the local recycling regulations to process, and use the best available techniques to achieve a relevant recycling efficiency.



## Annex 1: Installation and System Turn-on Process List

Tick after completion	No.	Item	Remark
<input type="checkbox"/>	1	Select the installation sites to meet all technical requirements.	Refer to <i>section 4.3</i> .
<input type="checkbox"/>	2	Battery base is installed following the technical requirements.	Refer to <i>section 4.4.1</i> .
<input type="checkbox"/>	3	Install the battery modules.	Refer to <i>section 4.4.2</i> .
<input type="checkbox"/>	4	Install the control module (BMS) and the battery module well.	Refer to <i>section 4.4.3</i> .
<input type="checkbox"/>	5	Connect D+ and D- between BMS to the inverter/PCS or confluence cabinet.	Refer to <i>section 5.3</i> .
<input type="checkbox"/>	6	Connect the grounding cable.	Refer to <i>section 5.2</i> .
<input type="checkbox"/>	7	Double check that all the power cables, communication cables, grounding cable are installed well.	Refer to <i>section 5.2 and 5.3</i> .
<input type="checkbox"/>	8	Switch on the external power or inverter/PCS, and ensure that all the power equipment can work normally.	Refer to <i>section 6.1</i> .
<input type="checkbox"/>	9	The first installation should do full charging progress automatically. If the status LED of BMS turns to blue, it means this battery string is in operation.	

## Annex 2: System Turn-off Process List

Tick after completion	No.	Item	Remark
<input type="checkbox"/>	1	Soft-off the inverter through inverter’s control panel.	Refer to <i>section 7.1</i> .
<input type="checkbox"/>	2	Turn off the switch between inverter and this battery string (Force-H2-V2), or turn off the power switch of inverter, to make sure no current through this battery string.	Refer to <i>section 7.1</i> .
<input type="checkbox"/>	3	Turn off the power switch of the BMS.	Refer to <i>section 7.1</i> .



**Pylon Technologies Co., Ltd.**

5/F, No.71-72, Lane 887, ZuChongzhi Road,  
China (Shanghai) Pilot Free Trade Zone,  
Pudong, Shanghai 201203, China

**T** +86-21-51317699 | **F** +86-21-51317698

**E** [service@pylontech.com.cn](mailto:service@pylontech.com.cn)

**W** [www.pylontech.com.cn](http://www.pylontech.com.cn)