



Mounting systems novotegra

The perfect solution for every roof

1 Introduction	08 About us and novotegra
	13 Certifications and approvals
	14 System planning with Solar-Planit
	18 Know-how, expertise and years of experience

2 Pitched roof	22 Mounting solutions for tile roofs
	38 Mounting solutions for trapezoidal panel roofs
	48 Mounting solutions for corrugated and sandwich roofs
	61 Mounting solutions for seamed metal roofs

3 Flat roofs	69 Mounting solutions for flat roofs
---------------------	--------------------------------------

4 Custom solutions	80 Facade system
	82 In-roof system

5 Single items	86 Roof attachment
	96 Profile rails
	102 Rail connectors and expansion joints
	107 Cross connectors
	109 Module protection and rail top cover
	113 Module attachment
	117 Elevation
	123 Facade system
	124 Sealing and protective components cable protection
	125 Accessories and optional components
	126 Tools

6 Appendix	129 Guarantee conditions
	130 Contact and imprint

r.e.think energy

BayWa r.e. is the energy designer of the future:
we are setting new renewable energy standards worldwide
with innovative solutions.

In all relevant areas, we support our customers
as a reliable market partner with a full-service range of
technical, planning and commercial services.

We make sure that more and more regions worldwide
produce and consume renewable energy and that our
customers profit from this added value.

YOUR PARTNER IN THE PHOTOVOLTAICS MARKET – NOW AND IN THE FUTURE

As one of the largest system providers worldwide, we are a partner for local installers and deliver high-quality components. Our customers know that we always give maximum effort. This was confirmed for us in 2019 for the eighth time in a row: the renowned market research institute EuPD Research rated us as one of the best large-scale trading companies in Germany, Europe and Australia.

On top of that, the quality seal “Top PV Supplier” confirms that we were awarded top marks by installers. But that's not all: Since quality and good service are especially important to us, we also had ourselves certified according to ISO 9001 by TÜV SÜD. An advantage which pays off for our customers.





“We do a lot to ensure the success of our customers. That is why BayWa r.e. regularly receives top marks.”

Thomas Pfaff,
Head of Product Management and Mounting Systems Purchasing

Alexander Schütt,
Managing Director, BayWa r.e. Solar Energy Systems GmbH

For the best products

We subject our products to the highest requirements. Our technicians look for the best solution for every requirement while conscientiously taking the feedback we receive from our customers into consideration. This is how we contribute to the continuous optimisation of components and, thus, yield increases. We stay in contact with leading specialists in the solar sector to continuously expand our knowledge and give the further development of photovoltaics crucial momentum.

For equal opportunity for our fellow human beings

For years, we have worked together with sheltered workshops in Baden-Wuerttemberg to preassemble individual parts of our novotegra mounting system. This collaboration offers people with disabilities and mental illness diverse chances and opportunities to be involved in working life and to develop themselves further.

As an IHK-certified company, we continuously provide young people with official training and increase their chances in the job market.

1

Introduction

That's why we are the right partner

Technical innovations and products alone are not enough.
With the right partner at your side, you benefit too.

INNOVATIVE SOLUTIONS FOR THE FUTURE

BayWa r.e. is the energy designer of the future.

The parent company BayWa AG recognised the challenges early on and in 2009 founded BayWa r.e renewable energy, which combines all renewable energy commitments in the solar energy, wind energy and bioenergy business units. Since then BayWa r.e. has grown into one of the most renowned project developers and trading companies in Germany and Europe, Asia, the USA and Australia.

The BayWa r.e. Solar Energy Systems trading company: Quality that pays

BayWa r.e. Solar Energy Systems GmbH has been banking on the sun as the number one energy supplier since 1991. Since then, we have actively been involved in the evolution of solar energy in Germany and continuously deepened our expertise in the area of photovoltaics. And because the obvious is not always the best, we go one step further and rethink systems.



Figures we want to be measured by

Quality and good service can only be reflected in figures to a limited extent.
Nevertheless, the following values say a lot about our performance.

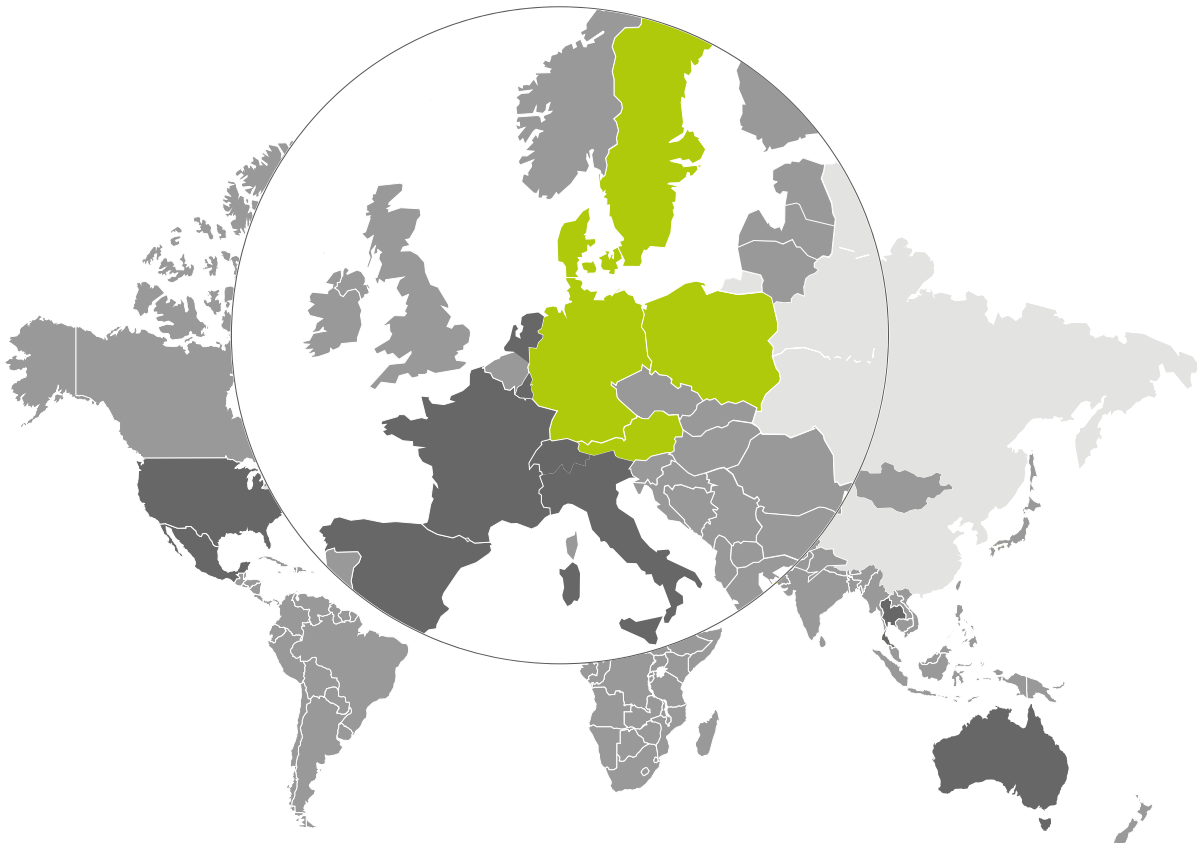

■ BayWa r.e. Solar Energy Systems locations
 ■ Further BayWa r.e. trading subsidiaries
 ■ Market development

- Our solar panels, which we deliver world-wide, produce an output of 2,400 MWp.
- All of the inverters we have sold so far produce around 4,500 MW of electricity.
- In 2018, our logistics department successfully delivered 75,000 shipments.
- More than 350 employees will assist you with any questions you may have about PV systems – from choosing the right product to planning your system.

Quality at all levels

More than 25 years of experience, expertise and passion
– we are your partner who can do more.

WHAT YOU GET FROM US

Personal and always close to you

With offices at five sites, a complete sales team with experts is at your disposal throughout Germany for all questions relating to photovoltaics. We believe it is particularly important that we know you and that you know us. That's why we don't have a general service hotline, but instead a direct line to your contact in our sales department.

Exploring new paths together – BayWa r.e. sales cooperations

Through our partner sales, we collaborate with sales partners who have close ties to possible end customers. Together, we develop individual business models to inform end customers about photovoltaics and provide tailored and attractive offers. We do all of this with the goal of sparking even more peoples' interest in photovoltaics. How do you profit? Photovoltaic installations are implemented for end customers using only selected professional installers and solar technicians from our network.



BayWa r.e. Solar Energy Systems GmbH
sales offices in Germany

Everything in one place – our warehouse and logistics centre

A top-performance warehouse and logistics centre is essential for us to be able to reliably deliver all articles ordered from this catalogue on time. More than 15,000 square metres of storage space provide enough room to keep all components in stock at all times. Quick delivery times and prompt shipping directly to the construction site guarantee top planning reliability.

Plan and order online – around the clock

You can quickly and easily check availability, prices and the latest products in our online shop. Use the product comparison for a better overview or the shopping lists for your project organisation – your personal customer account gives you all the information you need at any time. Take a look at solar-distribution.baywa-re.de.

LONG-TERM OUTSTANDING QUALITY

Quality and good service are our top priorities. We've confirmed this with a TÜV SÜD certification to ISO 9001.

But what is particularly important to us is a good cooperation with you: For the eighth time in a row, we have been awarded the quality seal "Top PV Supplier" by the renowned Bonn market research institute EuPD Research.



More than 15000 square meters of warehouse space

We are setting new standards with novotegra

We have developed a highly efficient mounting system.
Because we do market research not in the office, but on the roof.



MAKE IT EASY FOR YOURSELF

A good photovoltaic mounting system is the basis for the photovoltaic installation. So there is a lot to consider when choosing the right system. novotegra makes your choice easy.

Guaranteed to last

Our novotegra mounting system is made of durable and corrosion-resistant materials and is – under consideration of the Eurocode resistance standards – extremely stable and able to withstand stress. It can even withstand heavy snow and wind loads.

Ideal for every application

No matter how varied the requirements, novotegra is the right system for every application. Whether pitched or flat roof, facade or special solutions – we have the right solution for your project.

THE PERFECT SOLUTION FOR ANY REQUIREMENT

Our mounting systems are as varied as the varying needs of our customers. Our two product lines, novotegra top-fix and novotegra side-fix, reflect our two systems for different roof types, tiled roofs and roofs covered in corrugated sheets of Eternit sheets or sandwich panel roofs. These symbols will guide you through our range of products. Decide for yourself which product line is perfect for you.

novotegra top-fix

The C-profile rail with integrated cable trough is always attached from above via long slot in the bottom of the rail, regardless of whether roof hook or hanger bolt are used.

top-fix



novotegra side-fix

The N-profile rails are fastened to the roof hooks and hanger bolts sideways and rest in a height-adjustable groove.

side-fix



We also offer perfect solutions for flat roofs with the novotegra east-west systems and the novotegra south systems.

„The first novotegra prototype was developed by us in 2006 and produced in a forge in Stuttgart. Even 13 years later and the product is still unique on the market.“

MARTIN SCHÄFER

Inventor and product manager of novotegra
BayWa r.e. Solar Energy Systems GmbH



In for a penny, in for a pound

A good system is one thing, but the right service is just as important.
Our free services will allow you to become a novotegra expert in no time.

FREE FIRST-TIME INSTALLATION SUPPORT

Are you using novotegra for the first time? We will support you – free of charge and directly on site! One of our installation technicians will come to your site for a whole day, install the system together with you and give you tips and tricks to help you on your way. This makes optimal installation very easy – and you will become a true novotegra expert.

HAVE YOU SEEN THEM? OUR INSTALLATION VIDEOS

You will find various installation videos for our systems on our YouTube channel. Whether as a preview or for help during an installation – our videos are always there wherever you go. Just click on www.youtube.de/novotegra or scan this QR-code with your smartphone:



OUR SPECIALIST SEMINARS

We offer Europe-wide mounting system workshops for our customers – at our sales locations in various countries and at our BayWa r.e. Solar Energy Systems headquarters in Tuebingen, Germany. At these workshops, you can install the system on the novotegra test roof, exchange information with colleagues in the industry and learn everything you need to know from our experts.

10 YEAR PRODUCT WARRANTY

We give you a 10-year product warranty on the novotegra mounting system, because:

- all components are made of durable materials,
- all components are optimally matched to each other,
- the mounting system is designed according to the Eurocode generation of standards.



Certifications and Approvals

novotegra stands for quality, high-quality materials and reliable production.
Together with our long-standing partners and independent instances
we ensure that this remains in the future.

TÜV RHEINLAND CERTIFICATION

The reliability and quality of our mounting system has been certified with the TÜV Rheinland test mark.
The inspection catalogue for the certification includes all building law and technical requirements that mounting systems must meet. This ensures that all our photovoltaic mounting systems are produced in the same way as the tested systems – with the same materials and processes and thus with the same quality.
By the way: our sales and support services also convinced the auditors.



CE MARKING

The in-house monitoring for the novotegra mounting system by BayWa r.e. Solar Energy Systems GmbH meets all mandatory requirements stipulated in EN 1090-1:2009+A1:2011, Annex ZA as the foundation of the CE marking within the framework of the EU Regulation no. 305/2011 (Construction Product Regulation – CPR). Execution in accordance with EN 1090-2 and EN 1090-3, EXC1.



GENERAL APPROVALS BY THE BUILDING AUTHORITIES

For your safety, we had the static calculations of relevant parts of the system checked by independent authorities. We prepared the approvals required for this in cooperation with an independent inspector and received the following general approvals from Deutsches Institut für Bautechnik (German Institute for Structural Engineering):

- Z-14.4-716: Connections for PV mounting systems
- Z-14.4-723: Rail connectors and base profile
- Z-14.4-735: Module attachments, module supports, cross rail connectors
- Z-14.4-741: Roof hooks, stock screws, attachments to the rail base



STRUCTURAL ANALYSIS CALCULATION WITH SOLAR-PLANIT

With our planning tool Solar-Planit, you can see the system structural analysis of our mounting system at the push of a button – and for free! The load determination for the structural analysis of the substructure is based on the specifications of Eurocode 1 – taking into account the national specifications of the countries that can be selected in the software. The only exception is Switzerland, where load is determined according to SIA 261 (2003) specifications.



Information on further international certificates can be obtained from your contact person.

A perfect affair: system planning with Solar-Planit

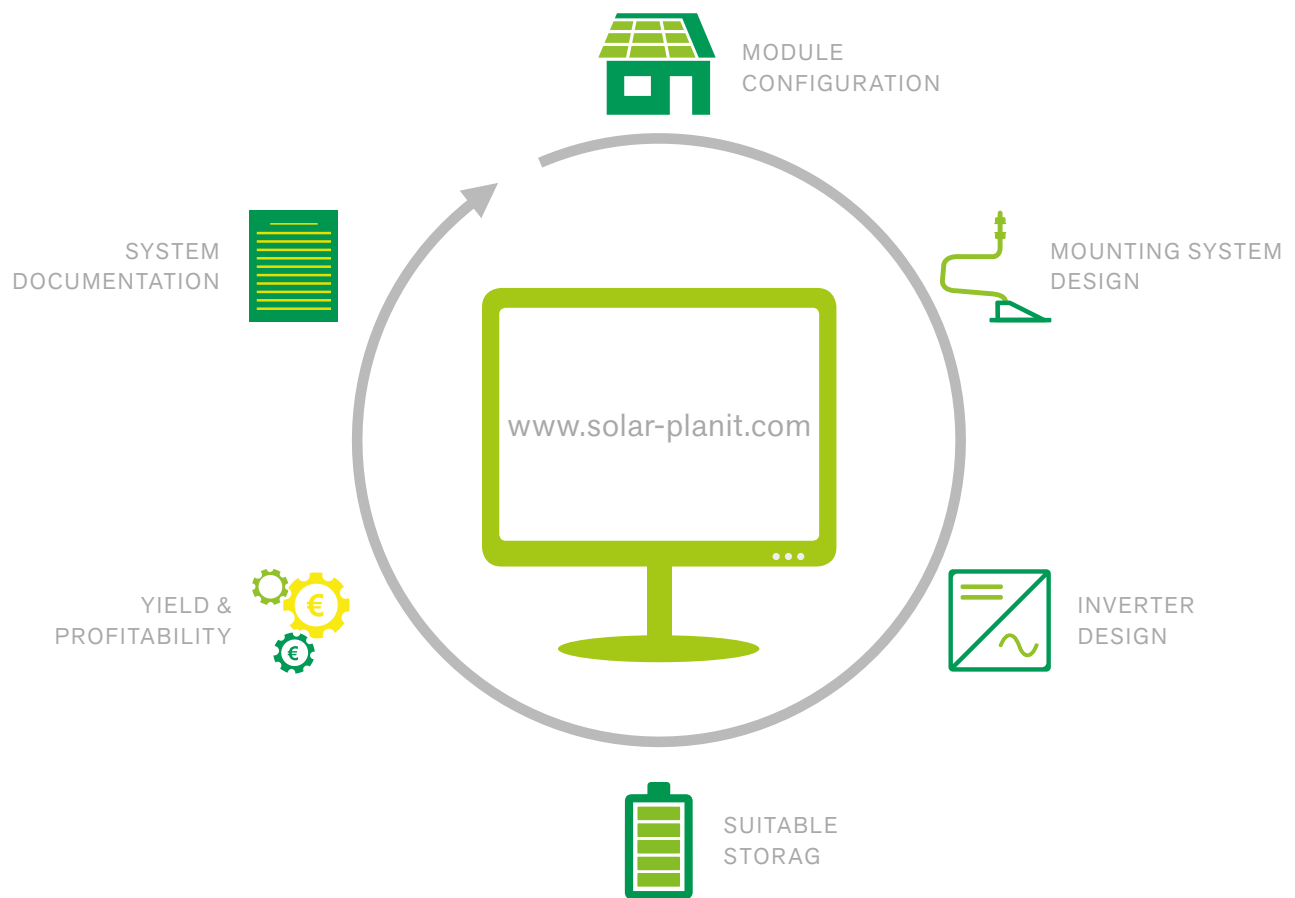

Your benefits

- Complete system planning, from installation to economic efficiency
- Free and web-based
- Recommendation of suitable components for your best price-to-performance ratio
- Static calculation according to Eurocode
- Determination of yield, profitability and own consumption ratio
- Clear documentation for you and your customers
- Free webinars on how to use Solar-Planit

Photovoltaic system planning "from A to Z" with Solar-Planit

Simple, clear, free of charge and web-based planning for your next installation.

WE TAKE "FROM A TO Z" LITERALLY

From accessories to connections and from the mounting system to battery storage – with Solar-Planit, you will succeed in designing a complete system that is perfectly suited to your site and your requirements. The geodata stored in Solar-Planit calculates all static requirements in accordance with Eurocode, depending on site and roof type – so you can always stay on the safe side. Solar-Planit also provides active assistance with component selection: you will receive suggestions based on the details you provide. Of course, you can also choose the components yourself – the program then checks whether everything is technically feasible. Register simply and free of charge at www.solar-planit.com or scan this QR-code with your smartphone:



Also visit our free Solar-Planit webinars and learn from our experts what you should pay attention to in your next planning.

GOING THE EXTRA MILE

The system design is one thing – Solar-Planit provides you with even more advantages that go beyond the pure design.

Parts list and price determination

When you are finished planning, you will receive an exact parts list including article numbers and prices. This means that you can provide your customers with a representative offer in as short a time as possible.

Sawing plan

A sawing plan for our novotegra mounting system saves you time and calculations.

Plant documentation and economic efficiency

When planning is complete, Solar-Planit can provide clear plant documentation for you and your customers. This contains additional information on economic efficiency and a yield forecast.

Teamwork – you determine the team

Because Solar-Planit is web-based, anyone can log in. So simply share your projects with your colleagues who have registered or your contact in our sales department and work together on planning.

Free of charge

Yes, all functions and accounts are completely free. No licences are required for Solar-Planit.



"Working with Solar-Planit is varied and never boring. New ideas, requirements and products require solutions and constant further development. Direct contact with our sales department enables us to respond to individual needs and close cooperation with our product management enables us to react quickly to product changes. Solar-Planit: for us, an exciting task from A to Z"

DANIEL GAUGGEL

IT/software development, BayWa r.e. Solar Energy Systems GmbH

Installation system layout with Solar-Planit

Project planning – self-contained, quick and simple.

PROJECT DATA

Entering data is quick, clear and easy!

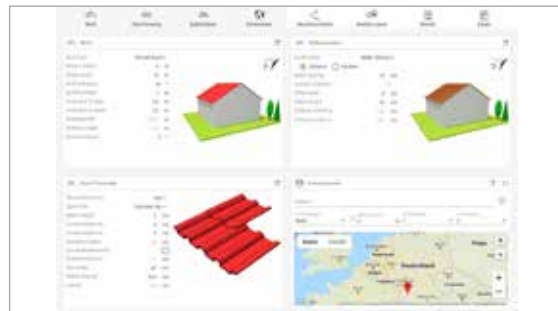

ROOF

1. Input roof dimensions

Roof Type	Pitched Roof ▾	
Ridge to eaves	6 m	
Ridge Length	10 m	
Roof Inclination	30 °	
Building Height	7 m	
Profusion of barg...	0,3 m	
Profusion of eaves	0,3 m	
Building Width	6,973 m	
Building Length	9,4 m	
Roof Orientation	0 °	

COVERAGE

2. Enter roof coverage data

Type of Roof Cove...	Tile ▾	
Type of tile	Concrete Tile ▾	
Batten Height	3 cm	
Counter batten hei...	3 cm	
Counter batten wi...	5 cm	
Insulation Height	0 cm	
Use additional woods	<input type="checkbox"/>	
Underlay thickness	0 cm	
Tile Length	40 cm	
Batten spacing	32,5 cm	
Overlap	7,5 cm	

ROOF CONSTRUCTION

3. Input roof construction details

Substructure	Rafter (Wood) ▾	
<input checked="" type="radio"/> Distance	<input type="radio"/> Number	
Rafter spacing	75 cm	
Number of Rafters	14	
Rafter width	8 cm	
Rafter Height	16 cm	
Distance of first ra...	0,5 cm	
Distance of last ra...	0,5 cm	

ENVIRONMENT

4. Select the locations

Address:

Security Category: Rural ▾

Altitude (m a.s.l.): 0 m

Windload Zone: ▾

Snowload Zone: ▾



Your benefits

- Define location and roof features individually for your project
- Select module and mounting system design – from tile roof to flat roof
- Plan the module configuration – easily plan around chimneys, skylights and dormers
- Perform a structural analysis and optimise the system – in line with the Eurocode standard for many European countries

Installation system layout with Solar-Planit

Solar-Planit lets you keep control of costs and statics.

MOUNTING SYSTEM

5. Choose the module and construction

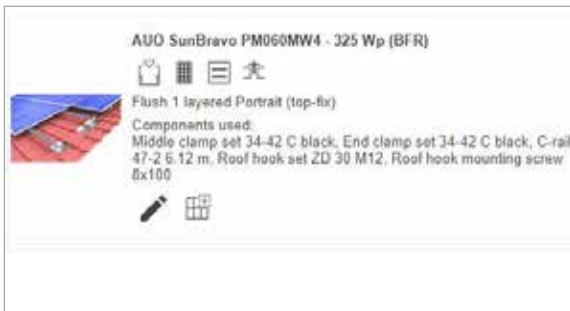

MODULE CONFIGURATION

6. Position hindering objects and modules



3D PREVIEW

7. Optional 3D preview

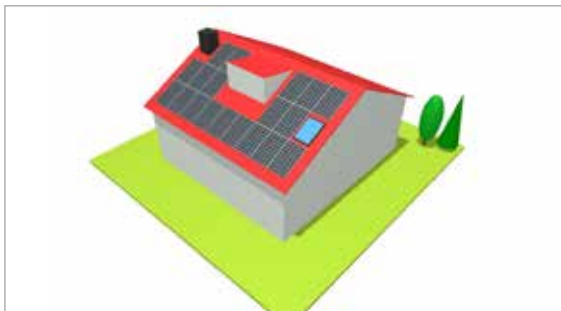

RESULTS

8. Material parts list including costs and statics

Item Nr	Description	Number of units	Amount per pack	Total price
03-000001	Rail connector set C47	2	1	10.56 €
03-000007	Module slip guard set M8	19	50	12.92 €
03-000012	Grounding connector set AF 18	5	10	20.10 €
03-000254	Roof hook set ZD 30 M12	36	50	325.44 €
03-000276	Middle clamp set 34-42 C black	28	100	56.00 €
03-000281	Roof hook mounting screw 8x100	36	50	9.00 €
03-000282	Roof hook mounting screw 8x140	36	50	14.04 €
03-000284	End clamp set 34-42 C black	20	20	42.00 €
03-000301	C-rail 47-2 5.12 m	8	30	588.00 €

DOCUMENTATION

Clear project report at the push of a button

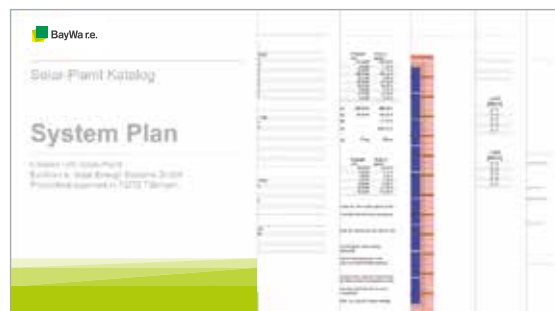

Your benefits

- The result: complete overview of the structural analysis, material requirements and costs
- System project reports – documentation for you and your customers at the push of a button
- Independent and self-contained planning – for our mounting system solutions
- This web-based solution makes short administrative paths possible for project collaboration either with your team or with our sales team

Know-how, expertise and years of experience

Our photovoltaics mounting system has performed successfully on the market for several years now – and worldwide as well.

From development to the first prototypes to series maturity:

Every component of our photovoltaic mounting system has its origin in our company. All components are tested extensively at our test bench with calibrated measurement instruments. Our international experience gain through sales and deployment across Europe and worldwide is incorporated into the further development of our products: This is why our mounting system takes country-specific details into account.

WELL EXPLAINED: OUR WORKSHOPS AND PROMOTIONAL MATERIAL

We offer Europe-wide mounting workshops for our customers – at our sales locations in various countries and at our BayWa r.e. Solar Energy Systems headquarters in Germany. We are very happy to provide you with promotional material which you can use to show your customers the benefits of our photovoltaic mounting system in an attractive and descriptive way. In addition to our catalogue, our brochures, the data sheets and the comprehensive information you can find on our website, you can also rent diverse promotional material for use at in-house exhibitions or during customer visits, for example – from models to promotional gifts to show trailers. We offer small mounting system models for rent or sale. If you want to learn more about our promotional materials: we are happy to help you personally.

OUR FREE FIRST-TIME INSTALLATION SUPPORT

Are you installing one of our mounting systems for the first time? Then take advantage of our free initial assembly service. This way you can get to know your mounting system from the inside out in a practical scenario. One of our technical consultants will spend an entire day with you on site. Our expert will give you a briefing, support you regarding any questions about the mounting system and help with the installation. He will go over the results of the structure analysis calculation by our Solar-Planit planning tool. Furthermore, you will get helpful tips and tricks related to our mounting system.

SECURITY: WIND TUNNEL TESTED FLAT ROOF SYSTEM

Our aerodynamic flat roof systems were tested in a boundary layer wind tunnel by experts from Wacker engineers in Birkenfeld, Germany according to the specifications in Eurocode DIN EN 1991-1-4/NA in. Only a boundary layer wind tunnel can accurately model the profiles of medium wind speed and turbulence intensity. The results of the wind tunnel tests are reflected in the system plans by our planning tool Solar-Planit – minimum ballast with maximum security.

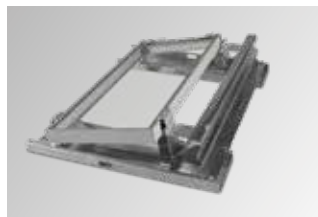

novotegra workshops
also directly at your location



2

Pitched roofs



Mounting solutions for tile roof

novotegra top-fix



Clamping system: Single-rail in portrait



Insertion system: In portrait



Clamping system: Single-rail in portrait on beaver tail tiles



Insertion system: In portrait on beaver tail tiles



Clamping system: Cross-rail in landscape



Insertion system: In landscape

Your benefits

- Clamping and insertion systems for mounting modules in portrait and in landscape
- Multiply adjustable roof hooks – unique design
- Rail with an integrated cable channel and room for plugs
- Quick mounting from above with easily graspable components



Mounting solutions for tile roof

novotegra side-fix



Clamping system: Single-rail in portrait



Insertion system: In portrait



Clamping system: Cross-rail in landscape



Insertion system: In landscape



Clamping system: Cross-rail in portrait

Your benefits

- Clamping and insertion systems for mounting modules in portrait and in landscape
- Robust, die-cast aluminium roof hooks – unmistakable
- Mounting the rail from the side with view of the mounting spot
- Clamping system with click mechanism, impossible to lose during mounting



novotegra top-fix – single-rail clamping system with modules installed in portrait

POWERFUL, STABLE AND FLEXIBLE

Our roof hook sets from the novotegra family are ideal for roof attachment when mounting modules on tile roofs. The various sets consist of a base profile and a bracket which is screwed into the base profile. Because they are three-way adjustable, the roof hook sets are perfectly adaptable to any tile roof. This way you can always achieve a homogenous module field, even on uneven roofs. Whether you choose a large base profile with a second bracket for heavy snow loads or the flex roof hook set for light loads – we always have a simple, stable and flexible solution for your tile roof.

C-rails are always mounted using the same principle: The classic screw connection with a locking nut ensures a quick, strong and permanently reliable connection for both single-rail and cross-rail connections. At the same time, the interior of the rail acts as a cable channel with enough room for cables and plugs.

All end and middle clamps are pre-assembled and also available in a black anodised variant. Be it vertically or horizontally installed modules or a single-rail or cross-rail installation, thanks to reliable clamping technology, modules can be attached to C-rails quickly and securely. The end clamps close the module field flush to the C-rails, making the substructure nearly invisible – for visually perfect installations.

YOUR BENEFITS

- Secure, stable and durable
- Three-way adjustable roof hooks
- The C-rail also acts as a cable channel
- Double roof hooks for heavy snow loads
- High-quality production and proven clamping technology
- Only three clamps for all frame heights
- For all conventional tiles and minimal tile adjustment
- Excellent rear ventilation of the module
- Simple, Eurocode-compliant layout with our Solar-Planit online tool



Double roof hooks for heavy snow loads



C47 S rail connectors for profile clamps



End cap on the edge of the installation

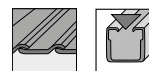

CLAMPING SYSTEM

Middle clamp or end clamp

Page 113



Item no. 03-000302



Item no. 03-000299



Item no. 03-000301



Item no. 03-000298

NOVOTEGRA TOP-FIX

End cap

Page 110

Item no. 03-000259



Connector

Page 103

Item no. 03-000001



Rail

Page 98

Item no. 03-000291



Roof hook

Page 86

Item no. 03-000254



Screws

Page 93

Item no. 03-000281





novotegra top-fix – single-rail clamping system on beavertail tile roofing with modules installed in portrait.

SOLUTION FOR BEAVERTAIL TILES

For the installation of our system on a beavertail tile roof, you can use the beavertail roof hook set or for lesser loads the flex roof hook set. The various sets consist of a base profile and a bracket which is screwed into the base profile. Due to their special shape, both the beavertail and the flex roof hooks are ideal for the small spaces between roof battens on a beavertail tile roof. In addition: The bracket fits between two tiles and not under the tile.

The roof hook sets are three-way adjustable and thus allow for the levelling of uneven roof surfaces to achieve a homogeneous module field. Because the bracket does not sit on the roof tile, you don't need any expensive underlay plates. This reduces the overall system costs.

The C-rail is connected easily, quickly and permanently to the roof hook using a conventional screw connection with a locking nut – it then serves simultaneously as a cable channel.

All end and middle clamps are pre-assembled and also available in a black anodised variant. Be it modules installed in portrait or landscape or a single-rail or cross-rail installation, thanks to reliable clamping technology, modules can be attached to C-rails quickly and securely. The end clamps close the module field flush to the C-rails, making the substructure nearly invisible – for visually perfect installations.

YOUR BENEFITS

- Secure, stable and durable
- Three-way adjustable roof hooks
- The C-rail also acts as a cable channel
- Double roof hooks for heavy snow loads
- Quick and easy mounting
- Excellent rear ventilation of the module
- Only three clamps for all frame heights
- Simple, Eurocode-compliant layout with our Solar-Planit online tool
- No beavertail sheet metal tile required



Position of the bracket with beavertail tiling



Rail connector C 47 S for profile chambers



End cap on the edge of the installation

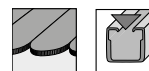

CLAMPING SYSTEM

Middle clamp or end clamp

Page 113



Item no. 03-000302



Item no. 03-000299



Item no. 03-000275



Item no. 03-000298

NOVOTEGRA TOP-FIX

End cap

Page 110

Item no. 03-000259



Connector

Page 103

Item no. 03-000925



Rail

Page 98

Item no. 03-000291



Roof hook

Page 87

Item no. 03-000258



Screws

Page 93

Item no. 03-000281





novotegra side-fix – single-rail clamping system with modules installed in portrait

QUICK AND EASY FIXING

From roofing shingles to concrete roofing tiles: novotegra is perfect for every tile roof. It is quick and easy to fix, offers several individual solution options and is extremely stable and able to withstand stress.

Our roof hooks facilitate the height-adjustable connection of the rail with the groove. The grooved guide rail can be connected to the slot bolt through the slot on the head of the roof hook and securely clamped over the fluting. The side connection eliminates high-effort mounting from below and provides a good view of the attachment point. The roof hooks are simply attached to the rafter and do not contact the roof, even under stress – expensive sheet metal tiles therefore are not necessary.

The grooved guide rails enable rail overhang beyond the attachment point on the roof hook. Depending on the rail diameter, they are available for various spans and can easily be extended using plug-in connectors which are screwed in from the side.

With its click-in mechanism, the clamping system comes with an extremely comfortable and secure mounting technology for attaching modules. You can install the modules vertically or horizontally, with a single rail or with cross-rails and benefit from low installation workload thanks to pre-assembled module clamps. The module clamps are available in blank aluminium or black. This creates a visually attractive, homogenous module field.

YOUR BENEFITS

- Secure, stable and durable
- Die-cast aluminium roof hooks without a welding seam
- Height-adjustable rail connection
- Easy-to-mount connection from the side
- Installation-friendly clamps with a click-in mechanism
- Pre-assembled components
- Quick and efficient mounting
- Only two clamps for all frame heights
- Simple, Eurocode-compliant layout with our Solar-Planit online tool



Roof hook with height-adjustment N-rail



Connector N-rail standard

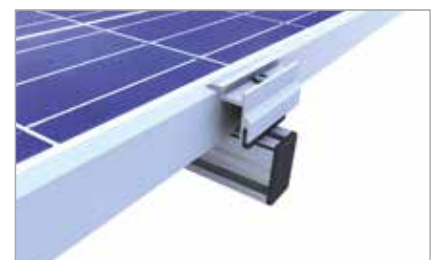

End clamp with spacer in N-rail



CLAMPING SYSTEM

Middle clamp or end clamp

Page 113 / 114



Item no. 03-000569



Item no. 03-000964



Item no. 03-000615



Item no. 03-000572



Item no. 03-000553

NOVOTEGRA SIDE-FIX

End cap

Page 111

Item no. 03-000529



Connector

Page 104

Item no. 03-000524



Rail

Page 98

Item no. 03-000965



Roof hook

Page 88

Item no. 03-000613



Screws

Page 93

Item no. 03-000281





novotegra top-fix – insertion system with modules installed in portrait

POSITION, INSERT – FINISHED!

Simple and elegant – our insertion system for tile roofs. Precisely adjust the substructure to your roof, and you will have a visually perfect PV installation thanks to the insertion system.

The insertion rails are available in either blank aluminium or black to match the frame colour, and the thought-through technology ensures security and mounting efficiency. As a floating installation, the module frame – vertical or horizontal – transfers the load to the rails. Insert the modules in the blink of an eye and lay the cables, including plugs, in the lower rail of the cross connection. The combination of the C-rail as a supporting rail and the cable channel makes it unique – tidy and efficient.

The connection of the C-rail to the rail bottom using a traditional screw connection on the three-way adjustable roof hook set enables continuous adjustment and levelling of the lower rail position. The adjustable bracket which is screwed into the base profile makes the roof hook easy to adapt to the roof coverage. The base profile facilitates precise positioning of the bracket over the tile – the roof hook set is available in different variations, perfect for your project.

The installation is completed with end caps and edge stops and can also be equipped with a snow guard – design and quality, that is what our insertion system stands for.

YOUR BENEFITS

- High-quality installation aesthetics
- Tension-free module mounting
- Easy and secure – stable and durable
- Three-way adjustable roof hooks
- Roof hooks for light and heavy loads
- The C-rail also acts as a cable channel
- Quick and efficient thanks to insertion technology and pre-assembled parts
- Excellent rear ventilation of the module
- Simple, Eurocode-compliant layout with our Solar-Planit online tool



Height-adjustable flex roof hook set



Rail connector insertion rail









Closing insertion rail and C-rail



INSERTION SYSTEM

Insertion rail	 Item no. 03-000540	Page 96
Connector	 Item no. 03-000499	Page 102
Edge stop	 Item no. 03-000693	Page 109

NOVOTEGRA TOP-FIX

Cross-rail connector	 Item no. 03-000321	Page 107
End cap	 Item no. 03-001111	Page 110
Connector	 Item no. 03-000001	Page 103
Rail	 Item no. 03-000291	Page 98
Roof hook	 Item no. 03-000254	Page 86
Screws	 Item no. 03-000281	Page 93



novotegra top-fix – insertion system on beavertail tile roofing with modules installed in portrait

CLASSIC MEETS MODERN – BEAVERTAIL WITH INSERTION SYSTEM

Are you looking for a photovoltaic mounting system for beavertail tile roofs with double tiling? By choosing our insertion system, you are choosing top-quality stability and safety and also an attractive appearance for your system – that matches the delicate and timelessly elegant beavertail tiling. Our insertion rails are available in blank aluminium or black, depending on the colour of your module frames. You get the best look for your project. The very slim and unobtrusive roof hooks and the C-rail to store the cables mean the substructure is nearly invisible.

Whether you choose the flex roof hooks for light loads or the BS roof hooks for higher loads, our roof hooks do not rest on the tiling, so they do not need expensive sheet metal tiles.

The adjustable roof hook set can be adjusted perfectly to the shape of the roof – the bracket is simply inserted between two neighbouring tiles. Stress-free storage of the modules in landscape or portrait, expertly laid cables in the integrated C-rail cable channel and secure fastening and flexible adjustment of the roof hooks to the roof – our system is unparalleled for this roof coverage.

YOUR BENEFITS

- Attractive and unmistakable appearance
- Quick and efficient thanks to insertion technology and pre-assembled parts
- Module installation – landscape and portrait – floating and tension-free
- Insertion rails in blank aluminium or black
- Excellent rear ventilation of the module
- Three-way adjustable roof hooks
- Roof hook without resting on tile – no sheet metal tiles required
- Simple, Eurocode-compliant layout with our Solar-Planit online tool



Position of base profile BS on rafters



Closing insertion rail and C-rail





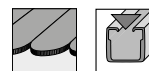

Rail connector insertion rail



INSERTION SYSTEM

Insertion rail	 Item no. 03-000540	Page 96
Connector	 Item no. 03-000499	Page 102
Edge stop	 Item no. 03-000693	Page 109

NOVOTEGRA TOP-FIX

Cross-rail connector	 Item no. 03-000321	Page 107
End cap	 Item no. 03-001110	Page 110
Connector	 Item no. 03-000001	Page 103
Rail	 Item no. 03-000291	Page 98
Roof hook	 Item no. 03-001149	Page 86
Screws	 Item no. 03-000281	Page 93



novotegra side-fix – insertion system with modules installed in portrait

PROVEN AND ATTRACTIVE

By choosing our insertion system for tile roofs, you are not only choosing top-quality, stability and security but also a highly attractive appearance for your photovoltaic installation.

The insertion rails hold the modules securely and gently: The floating installation of the modules in the rails distributes the load across the entire length of the module frame. The insertion system makes quick and easy installation of modules in landscape or portrait possible, ensures excellent rear ventilation and is also available with a snow guard.

The installation in a cross connection construction gives you the highest degree of flexibility. Our roof hooks are three-way adjustable for flexible adjustment on existing uneven roofs or one-way adjustable for quick fixing on new roofs. They are simple to fix – without broken tiles or expensive sheet tiles – and enable a height-adjustable connection of the lower rail with the groove. The insertion rails are connected to the grooved guide rails with the pre-assembled cross-rail connector set. The insertion rails are available in blank aluminium or black, depending on the colour of your module frames.

When used together with other decent mounting system components, this system creates an attractive, highly homogenous module field. Every roof turns into a design object with a uniform construction of black anodised insertion rails and dark modules.

YOUR BENEFITS

- Attractive and unmistakable appearance
- Floating and tension-free module installation
- Easy and secure - stable and durable
- Die-cast aluminium roof hooks without a welding seam
- Height-adjustable rail connection
- Easy-to-mount connection from the side
- Quick and efficient thanks to insertion technology and pre-assembled parts
- Low substructure clearance to the roof coverage
- Simple, Eurocode-compliant layout with our Solar-Planit online tool



Roof hook with height-adjustment N-rail



Rail connector insertion rail









Insertion rail on N-rail

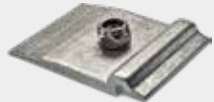

INSERTION SYSTEM

Insertion rail	 Item no. 03-000540	Page 96
Connector	 Item no. 03-000499	Page 102
Edge stop	 Item no. 03-000693	Page 109

NOVOTEGRA SIDE-FIX

Cross-rail connector	 Item no. 03-000409	Page 107
End cap	 Item no. 03-000529	Page 111
Connector	 Item no. 03-000524	Page 104
Rail	 Item no. 03-000965	Page 98
Roof hook	 Item no. 03-000612	Page 88
Screws	 Item no. 03-000281	Page 93

Mounting solutions for tile roof

Further applications



novotegra top-fix: Insertion system in portrait



novotegra side-fix: Insertion system in portrait



novotegra top-fix: Cross-rail clamping system on beavertail tiles







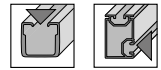







novotegra side-fix: Single-rail clamping system in landscape

Combination matrix for mounting system components



The following table illustrates the possible combinations of profile rails and roof attachments. These combinations apply for both the clamping systems (page 24 et seq.) and the insertion systems (page 30 et seq.).

		PROFILE RAIL			
					
		N-RAIL ECO 03-000679	N-RAIL STANDARD 03-000965	C-RAIL 38 03-001074	C-RAIL 47 03-000291
ROOF ATTACHMENT	 Roof hook set ZD adjustable 633 vertical M8 03-000949	✓	✓		
	 Roof hook set ZD 533 vertical M8 03-000612	✓	✓		
	 Roof hook set ZD 544 horizontal M8 03-000613	✓	✓		
	 Roof hook set flex 30 40 M10 03-001149 03-001151			✓	✓
	 Double Roof hook set flex 30 40 M10 03-001150 03-001152			✓	✓
	 Roof hook set ZD 30 40 M12 03-000254 03-000256			✓	✓
	 Double Roof hook set ZD 30 40 M12 03-000255 03-000257			✓	✓
	 Roof hook set BS 30 M12 03-000258			✓	✓
	 Double Roof hook set BS 30 M12 03-000267			✓	✓

All individual products can be found in chapter 5 from page 86 or on our website: solar-distribution.baywa-re.de/en/

Mounting solutions for trapezoidal roofs

Roof-parallel applications with direct fixing



Clamping system: In portrait short rail



Insertion system: In portrait



Clamping system: In landscape short rail



Insertion system: In landscape short rail

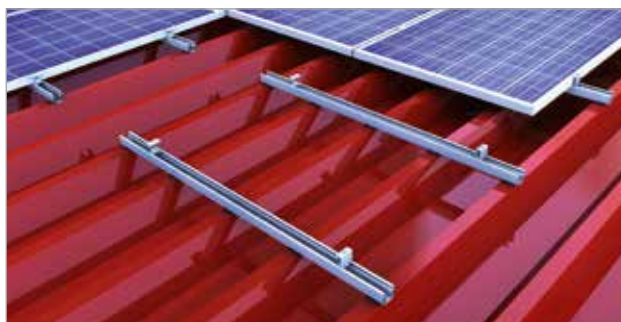

Clamping system: In portrait rail pieces

Your benefits

- Clamping and insertion systems for mounting modules in portrait or in landscape
- Only a handful of components, low installation workload and cost-effective
- Quick mounting thanks to direct fixing with chipless screws
- Easy layout planning with Solar-Planit – 10-year product guarantee

Mounting solutions for trapezoidal roofs

Elevated applications with direct fixing



Clamping system: South-facing



Insertion system: South-facing with triangle on bridge



Clamping system: South-facing on east-west roof

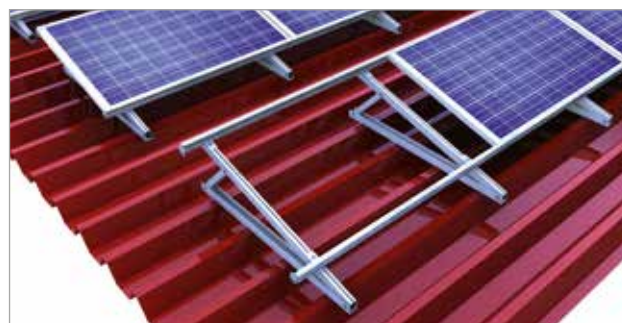

Insertion system: South-facing with triangle on east-west roof



Clamping system: In Portrait

Your benefits

- For elevation angles of 3 - 18° or 13 - 40°
- Module elevation solutions for all roof orientations
- Insertion system with elevation triangles for direct fixing
- Rail solutions with module attachment according to manufacturer specifications



Clamping system with direct fixing and modules installed in landscape

PRE-ASSEMBLED COMPONENTS – QUICK ASSEMBLY

With our clamping system for trapezoidal metal roofs, we always have the right solution completely pre-assembled for you. Whether for the yield-optimised system or the project business, or blank aluminium or black – you get a proven mounting system with a high quality of finish and made from durable and corrosion-resistant materials. Our clamping system for trapezoidal metal roofs also gives you an attractive price-performance ratio.

With the building authority-approved thin sheet screws, you can attach the pre-cut short rails, which are pre-equipped with EPDM sealing strips, directly to the trapezoidal raised beads. The modules are then attached with the tried and tested middle and end clamps – we cover all frame heights from 28 – 52 mm with only three different clamps.

Easy on-site handling guarantees quick and efficient mounting from above without saw or drill chips. You only need one tool to complete the installation, as the thin sheet screws and the clamps use an identical drive.

Excellent rear ventilation of the modules, electrical conductivity between mounting systems and the roof membrane as well as minimal material use and attractive aesthetics are all additional advantages of our mounting system, leaving no wish unfulfilled.

YOUR BENEFITS

- Only a handful of components – entirely pre-assembled
- Only one mounting tool necessary
- Easy and secure – attached directly to the trapezoidal sheet
- Electrically conductive connection between the mounting system and the roof membrane
- For steel panel thicknesses from 0.4 mm
- Quick mounting from above
- Short rails available in two different heights
- Simple, Eurocode-compliant layout with our Solar-Planit online tool

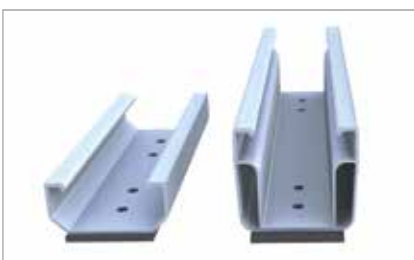

Short rail variations with EPDM seal

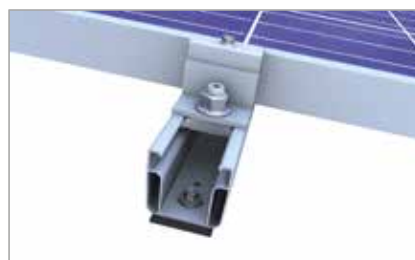

Slip guard on short rail for landscape



Hole pattern short rail for portrait



CLAMPING SYSTEM

Middle clamp or end clamp

Page 113



Item no. 03-000302



Item no. 03-000299



Item no. 03-000301



Item no. 03-000298

MODULE IN LANDSCAPE

Slip guard

Page 111



Item no. 03-000233

Page 111



Item no. 03-000233

Rail

Page 98



Item no. 03-000841

Page 98



Item no. 03-001108

Roof attachment

Page 93



Item no. 03-000880

Item no. 03-000893

Page 93



Item no. 03-000880

Item no. 03-000893



Clamping system with direct fixing and modules installed in portrait

VERTICAL MODULE INSTALLATION – ALWAYS THE RIGHT SOLUTION

Our systems – your choice! The versions with the short rail C24 and C47 are easy to handle on site thanks to their pre-assembled components. Or you might decide on the C-rail assembly. Then you'll get neat cable routing and a load-distributing connection to the trapezoidal sheet. Our clamping systems for modules in portrait meet every requirement.

When assembling on short rails, you use our 385 mm long, pre-punched module support profiles pre-assembled with EPDM seal. The short rails can be adjusted flexibly to all trapezoidal sheet corrugation grids and are available in two different heights. With the short rail C24, you get a material-saving and economical solution for your projects. Or you can use the short rail C47 and get the ideal rear ventilation of the modules due to sufficient space to the roof coverage. Whichever way you decide, with our short-rail versions, every choice is the right one!

To meet your requirements for even load distribution on a trapezoidal sheet and for neat cable routing at the same time, we recommend our C-rail solution. These rails are mounted on pre-stuck EPDM sealing strips using several raided beads. Whether you are using material-optimised C-rail 38 or proven C-rail 47, you get both rails in a length of 2.10 m – just lay them, screw them in and you're finished!

YOUR BENEFITS

- Quick mounting from above
- Only one mounting tool necessary
- Only a handful of components – entirely pre-assembled
- Short rails or C-rails in two different heights
- Only three clamps for all frame heights
- Fastening with building authority-approved thin sheet screws
- Conductive connection between the mounting system and the roof membrane
- Solution for roofs with low load reserves
- Simple, Eurocode-compliant layout with our Solar-Planit online tool

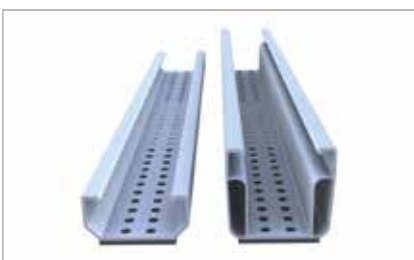

Versions of short rail 385 mm



Hole pattern short rail for portrait



Middle clamp in short rail C47



CLAMPING SYSTEM

Middle clamp or end clamp

Page 113



Item no. 03-000302



Item no. 03-000299



Item no. 03-000301



Item no. 03-000298

MODULE IN PORTRAIT

Slip guard

Page 110

Page 110



Item no. 03-000007



Item no. 03-000007

Rail

Page 99

Page 99

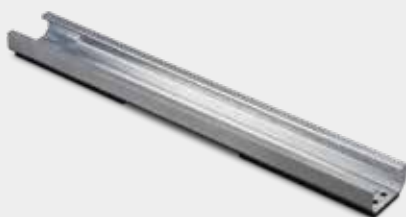

Item no. 03-001081



Item no. 03-000873

Roof attachment

Page 93

Page 93



Item no. 03-000880

Item no. 03-000893



Item no. 03-000880

Item no. 03-000893



Insertion system with direct fixing and modules installed in portrait

CONVINCING QUALITY FOR YOUR TRAPEZOIDAL ROOF

The insertion system from novotegra enables tension-free, floating – and at the same time very secure and stable – installation of your photovoltaic modules. The modules are gently placed in our insertion rails, which are available in either blank aluminium or black, with their entire frame length. Depending on the combination of rail and module, you can create a very aesthetic and homogeneous installation surface with the insertion mounting system. The insertion mounting system is also popular because of its thought-through construction, resulting in a quick and easy assembly with high-quality, durable and corrosion-resistant components.

The insertion rail is attached directly to the trapezoidal sheet using a fixing clamp which is attached to the side of the raised bead. Our insertion system for trapezoidal roofs can be used starting at a steel plate thickness of 0.4 mm. It provides excellent rear ventilation of the modules, which can be installed either vertically or horizontally.

Very practical for installation on the roof: the insertion system for trapezoidal roofs consists of only a handful of individual components, greatly simplifying installation. For trapezoidal roofs, we use building authority-approved chipless thin sheet screws which are screwed into the trapezoidal metal without producing any chips which could corrode.

YOUR BENEFITS

- Attractive and unmistakable appearance
- Only a handful of components – entirely pre-assembled
- Quick and efficient thanks to insertion technology and pre-assembled parts
- Floating and tension-free module installation
- Insertion rails in blank aluminium or black
- Easy and secure – attached directly to the trapezoidal sheet
- For steel panel thicknesses from 0.4 mm
- Excellent rear ventilation
- Simple, Eurocode-compliant layout with our Solar-Planit online tool



Insertion rail on EPDM with trapezoidal clamp

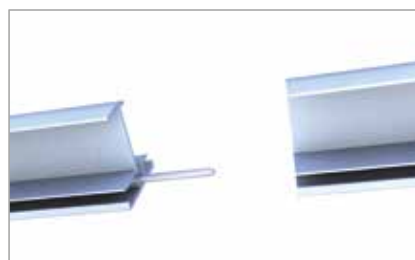

Connecting insertion rails on trapezoidal sheet



Module security at low roof inclination



INSERTION SYSTEM

Insertion rail		Page 96 Item no. 03-000492
Connector		Page 102 Item no. 03-000647
Edge stop		Page 109 Item no. 03-000691

ATTACHMENT SYSTEM

EPDM sealing strips		Page 124 Item no. 03-000633
Roof attachment		Page 92 Item no. 03-000459

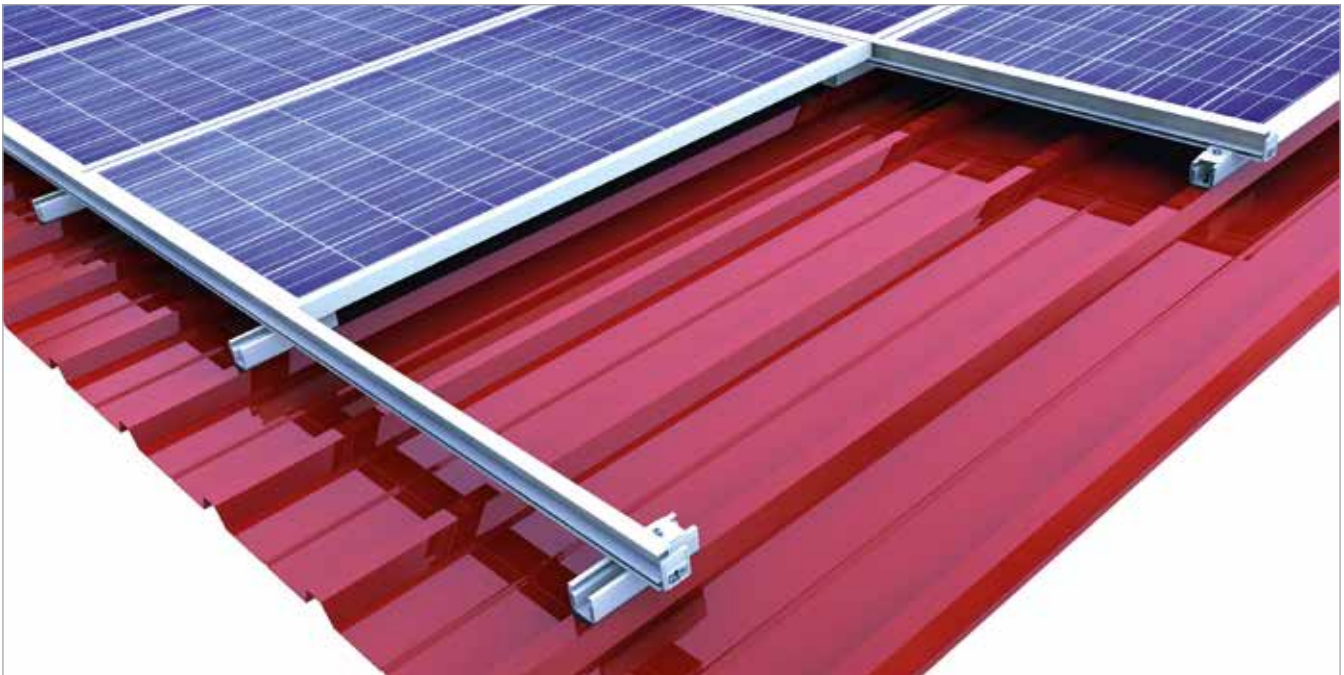

Insertion system with direct fixing and modules installed in portrait

COMBINED – INSERTION RAILS ON SHORT RAIL

Do you value the advantages of quick module assembly with our insertion system and would also like excellent rear module ventilation? Then we have exactly the right solution for your trapezoidal metal roofs, using the combination of our insertion rails and our various short rails.

Regardless of whether the modules are portrait or landscape, the sub-structure is constructed according to the same principle. You decide, depending on your rear module ventilation requirements, on the height of your short rail, and fasten these directly to the trapezoidal roof using building authority-approved thin sheet screws – this means you can choose between two short rails of different heights.

The insertion rails are placed on the short rails and are fastened with pre-assembled cross rail connector set C ES M8. The complete assembly of the components – whether the short rails are assembled or insertion rails fastened – is done from above.

With the combination of our insertion rails on short rails, you can combine the aesthetic appearance of your PV system thanks to the insertion system with optimal rear module ventilation for yield optimisation. Fewer components – completely pre-assembled – make assembly easy and quick.

YOUR BENEFITS

- Attractive and unmistakable appearance
- Short rails available in two different heights
- Only a handful of components – entirely pre-assembled
- Quick and efficient thanks to insertion technology and pre-assembled parts
- Floating and tension-free module installation
- Insertion rails in blank aluminium or black
- Easy and secure – attached directly to the trapezoidal sheet
- For steel panel thicknesses from 0.4 mm
- Yield optimisation due to excellent rear ventilation of the module
- Simple, Eurocode-compliant layout with our Solar-Planit online tool

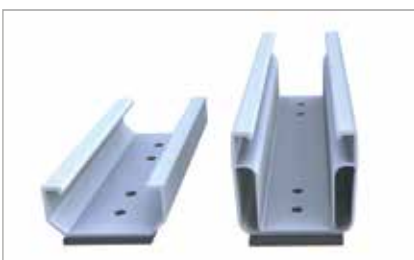

Short rail variations with EPDM seal



Module security at low roof inclination



Insertion rail attached to short rail

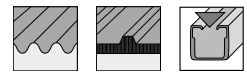

INSERTION SYSTEM

<p>Insertion rail</p>	 <p>Item no. 03-000492</p> <p style="text-align: right;">Page 96</p>
<p>Connector</p>	 <p>Item no. 03-000648</p> <p style="text-align: right;">Page 102</p>
<p>Edge stop</p>	 <p>Item no. 03-000691</p> <p style="text-align: right;">Page 109</p>

SHORT RAIL C24

SHORT RAIL C47

<p>Cross-rail connector</p>	 <p>Item no. 03-000321</p> <p style="text-align: right;">Page 107</p>	 <p>Item no. 03-000321</p> <p style="text-align: right;">Page 107</p>
<p>Rail</p>	 <p>Item no. 03-000841</p> <p style="text-align: right;">Page 98</p>	 <p>Item no. 03-001108</p> <p style="text-align: right;">Page 98</p>
<p>Roof attachment</p>	 <p>Item no. 03-000880 Item no. 03-000893</p> <p style="text-align: right;">Page 93</p>	 <p>Item no. 03-000880 Item no. 03-000893</p> <p style="text-align: right;">Page 93</p>



Mounting solutions for corrugated and sandwich roof

novotegra top-fix

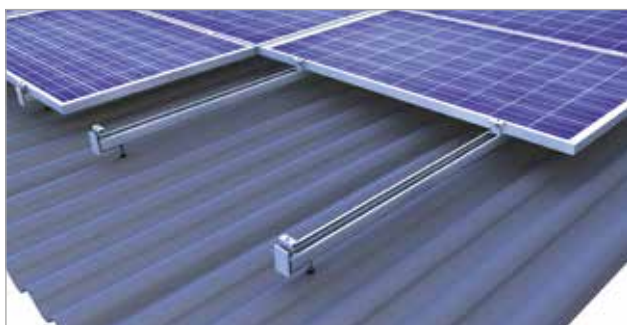

Clamping system: Single-rail in landscape

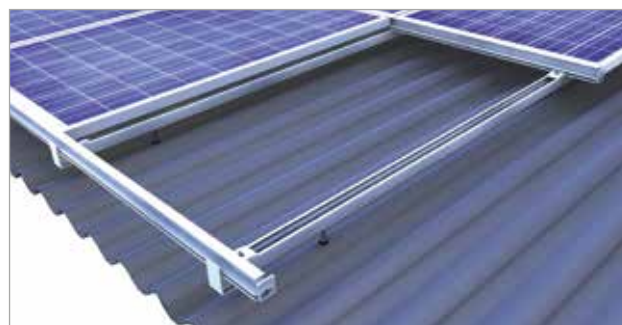

Insertion system: In portrait

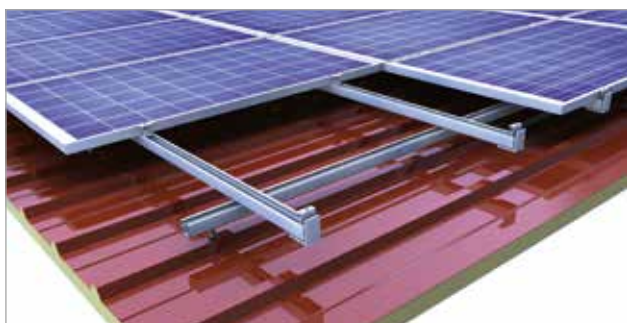

Clamping system: Cross-rail in portrait



Insertion system: In landscape

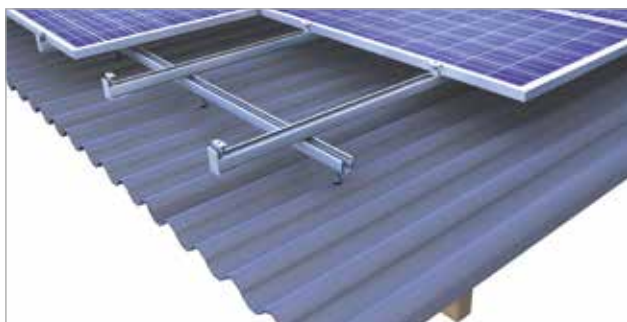

Clamping system: Cross-rail in landscape

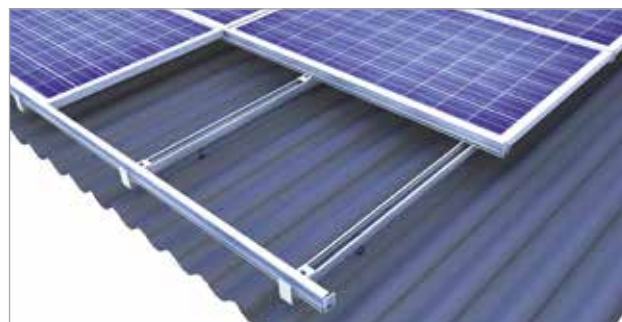

Insertion system: In landscape

Your benefits

- Clamping and insertion systems for mounting modules in portrait and in landscape
- Centric load distribution to the stock screw, making the system suitable for very heavy loads
- Rail with an integrated cable channel and room for plugs
- Quick mounting from above with easily graspable components



Mounting solutions for corrugated and sandwich roof

novotegra side-fix

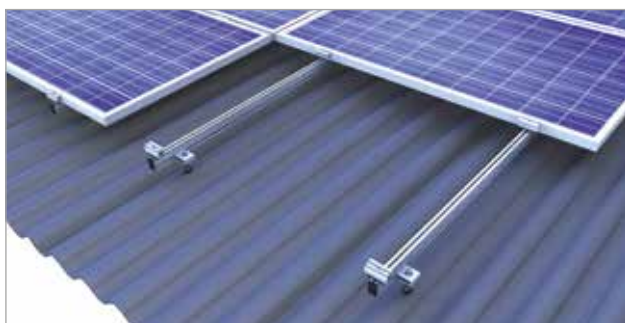

Clamping system: Single-rail in landscape

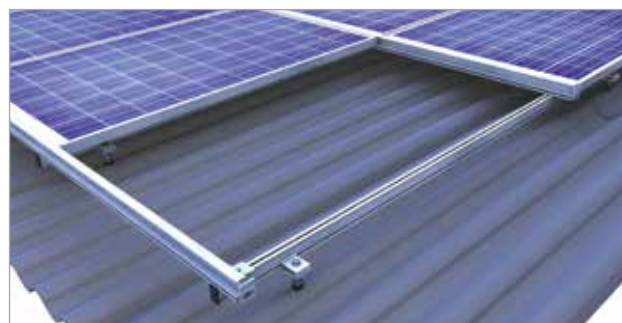

Insertion system: In portrait



Clamping system: Cross-rail in landscape

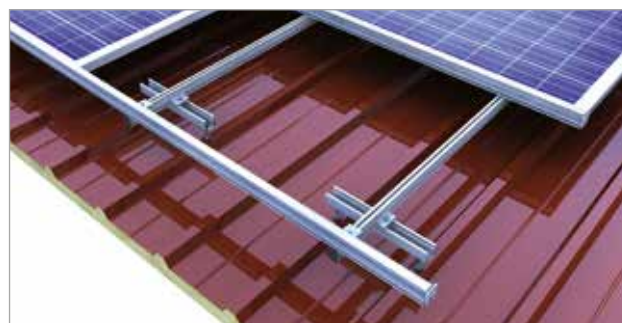

Insertion system: In landscape with bridge

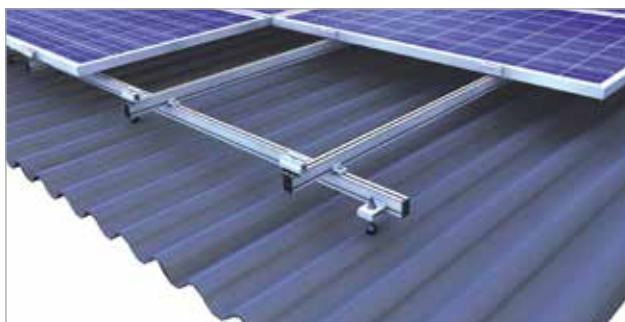

Clamping system: Cross-rail in landscape



Insertion system: In landscape

Your benefits

- Clamping and insertion systems for mounting modules in portrait and in landscape
- Stock screw with click adapter for the rail groove
- Side-mounting on the rail with a view of the mounting spot
- Clamping system with click mechanism, impossible to lose during mounting



novotegra top-fix – single-rail clamping system with modules installed in landscape

SIMPLE MOUNTING SYSTEM TECHNOLOGY

When mounting on corrugated and sandwich roofs, you fix the photovoltaic installation directly to the purlins of the roof construction. For wooden purlins, you need the stock screw set for wood and for steel purlins the stock screw set for steel. The centric connection of the C-rails to the stock screw transfers the load centrally on the stock screw – this means that it is not additionally subjected to bending stress.

C-rails are always mounted using the same principle: The classic screw connection with a locking nut ensures a quick, strong and permanently reliable connection for both single-rail and cross-rail connections. At the same time, the interior of the rail acts as a cable channel with enough room for cables and plugs. The connection of the stock screw to the rail bottom makes height adjustment possible, and the installation can be levelled – this way you can achieve a homogenous module field, even on uneven roofs.

All end and middle clamps are pre-assembled and also available in a black anodised variant. Be it modules installed in portrait or landscape or a singlerail or cross-rail installation, thanks to reliable clamping technology, modules can be fixed to C-rails quickly and securely. The end clamps close the module field flush to the C-rails, making the substructure nearly invisible – for visually perfect installations.

YOUR BENEFITS

- Centric load distribution
- The C-rail also acts as a cable channel
- For wooden and steel purlins
- Secure, stable and durable
- High-quality production and proven clamping technology
- Only three clamps for all frame heights
- Also suitable for trapezoidal roofs
- Excellent rear ventilation of the module
- Simple, Eurocode-compliant layout with our Solar-Planit online tool



Centric load distribution in to the stock screw



Cross-rail connection C-rail



Middle clamp on C-rail

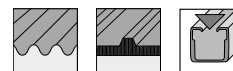

CLAMPING SYSTEM

Middle clamp or end clamp

Page 113



Item no. 03-000302



Item no. 03-000299



Item no. 03-000301



Item no. 03-000298

NOVOTEGRA TOP-FIX

End cap

Page 110

Item no. 03-000259



Connector

Page 103

Item no. 03-000001



Rail

Page 98

Item no. 03-000291



Stock screw

Page 89

Item no. 03-000222





novotegra side-fix – single-rail clamping system modules installed in landscape

EASY AND STABLE, PROVEN AND FLEXIBLE

Our mounting system with stock screws is installed on sandwich and corrugated roofs. The stock screw provides a high degree of flexibility: It is available in various diameters for diverse construction heights, insulation thicknesses and wooden and steel purlins. The rails are mounted using a simple click-in method from the side. Together with the reliable module clamping technology, this is a very secure and stable attachment for photovoltaic installations which has proven itself over years of use.

With novotegra, you can achieve the perfect system layout – for every single requirement of sandwich and corrugated roofs. With the clamping technology, the modules can be installed either vertically or horizontally, and the substructure can be installed on a single rail or in a cross-rail connection. The rails are available for various spans. They can be extended using plug-in connectors – even overhangs are possible.

With its click-in mechanism, the clamping system comes with an extremely comfortable and secure mounting technology for attaching modules to the grooved guide-rails. Using only two different clamping types, available in either blank aluminium or black, you can attach all frame heights.

Our mounting system will win you over with its top-grade production quality; our components are made of durable, corrosion-resistant materials.

YOUR BENEFITS

- Base plate height-adjustable on the stock screw
- N-rail to base plate clip-in installation
- For wooden and steel purlins
- Quick and efficient mounting
- High-quality production and proven clamping technology
- Installation-friendly clamps with a click-in mechanism
- Only two clamps for all frame heights
- Also suitable for trapezoidal roofs
- Excellent rear ventilation of the module
- Simple, Eurocode-compliant layout with our Solar-Planit online tool



Base plate stock screw in the groove



Cross-rail connection N-rails

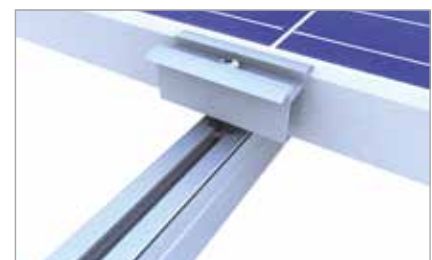

Middle clamp on N-rail

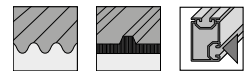

CLAMPING SYSTEM

Middle clamp or end clamp

Page 113 / 114



NOVOTEGRA SIDE-FIX

End cap

Page 111

Item no. 03-000529



Connector

Page 104

Item no. 03-000524



Rail

Page 98

Item no. 03-000965



Stock screw

Page 89

Item no. 03-000561



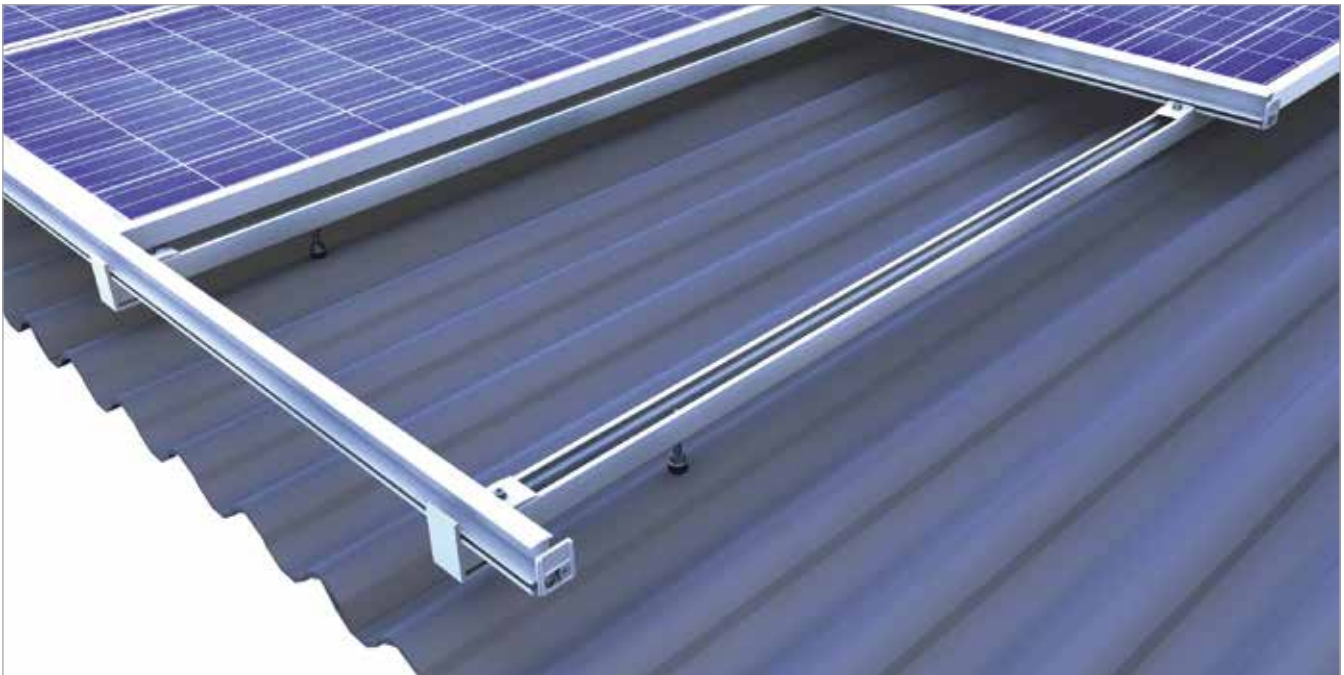

novotegra top-fix – insertion system with modules installed in portrait

EASY, STABLE AND FLEXIBLE

Whether you have a purlin roof with wooden or steel purlins, or a roof covering with corrugated or sandwich elements, with our stock screw set you can use our insertion system quickly and easily in your projects.

The insertion rails are available in either blank aluminium or black to match the frame colour. The well-thought-out technology ensures security and mounting efficiency. As a floating installation, the module frame – vertical or horizontal – transfers the load to the rails. Insert the modules in the blink of an eye and lay the cables, including plugs, in the lower rail of the cross connection. The combination of the C-rail as a supporting rail and the cable channel makes it unique – tidy and efficient.

The connection of the C-rail to the stock screws using a traditional screw connection on the rail bottom enables continuous adjustment and levelling of the lower rail position. The centre connection of the C-rails to the stock screw transfers the load centrally on to the stock screw, meaning that it is not additionally subjected to bending stress – the stock screw set is available in various lengths and widths, perfect for any roof.

The installation is completed with end caps and edge stops and can also be equipped with a snow guard – design and quality, that is what our insertion system stands for.

YOUR BENEFITS

- High-quality installation aesthetics
- Tension-free module mounting
- Quick and efficient thanks to insertion technology and pre-assembled parts
- Centric load distribution
- The C-rail also acts as a cable channel
- For wooden and steel purlins
- Secure, stable and durable
- Also suitable for trapezoidal roofs
- Simple, Eurocode-compliant layout with our Solar-Planit online tool



C-rail for various spans



C-rail connector extern

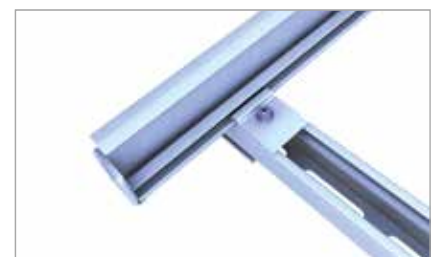

Fixation insertion rail to C-rail

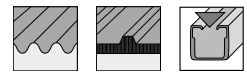

INSERTION SYSTEM

Insertion rail	 Item no. 03-000492	Page 96
Connector	 Item no. 03-000648	Page 102
Edge stop	 Item no. 03-000691	Page 109

NOVOTEGRA TOP-FIX

Cross-rail connector	 Item no. 03-000321	Page 107
End cap	 Item no. 03-000259	Page 110
Connector	 Item no. 03-000001	Page 103
Rail	 Item no. 03-000291	Page 98
Stock screw	 Item no. 03-000222	Page 89



novotegra side-fix – insertion system with modules installed in portrait

IDEAL FOR CORRUGATED AND SANDWICH ROOFS

High quality, upheld for years and thought through down to the last detail: The insertion mounting system makes secure and stable attachment of photovoltaic installations possible on any corrugated or sandwich roof. The insertion rails, in either blank aluminium or black, use floating, tension-free installation of the modules, holding them gently. They enable very fast module installation both vertically and horizontally. If desired, the insertion rails can also be equipped with a snow guard – as additional protection against roof avalanches.

Our stock screw sets for steel and wooden purlins enable mounting on various coverings and construction heights. Depending on the purlin distancing, the N-rail - diameter matching the required span - as lower rail in the cross connection transfers the load securely and stably to the stock screw.

The pre-assembled stock screw base plates enable easy clip-in mounting from the side into the groove – this gives you a good view of the attachment point. The insertion rails are then connected to the grooved guide rails with the preassembled cross-rail connector set – finished.

Our insertion system for corrugated and sandwich roofs is suitable for very heavy loads and ensures excellent rear ventilation of the photovoltaic installation. All components are made of durable, corrosion-free materials.

YOUR BENEFITS

- Attractive and unmistakable appearance
- Floating and tension-free module installation
- Quick and efficient thanks to insertion technology and pre-assembled parts
- Base plate height-adjustable on the stock screw
- N-rail to base plate clip-in installation
- For wooden and steel purlins
- Secure, stable and durable
- Also suitable for trapezoidal roofs
- Simple, Eurocode-compliant layout with our Solar-Planit online tool



N-rail on stock screw bridge



N-rail for various spans

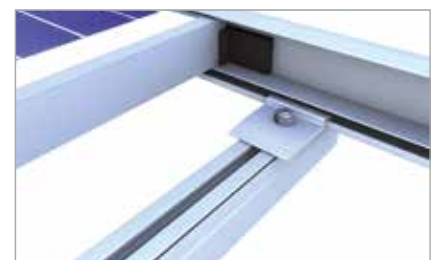



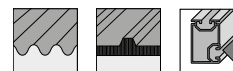

EPDM T protection module in insert rail

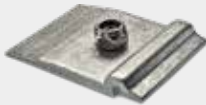

INSERTION SYSTEM

Insertion rail	 Item no. 03-000492	Page 96
Connector	 Item no. 03-000648	Page 102
Edge stop	 Item no. 03-000691	Page 109

NOVOTEGRA SIDE-FIX

Cross-rail connector	 Item no. 03-000409	Page 107
End cap	 Item no. 03-000529	Page 111
Connector	 Item no. 03-000524	Page 104
Rail	 Item no. 03-000965	Page 98
Stock screw	 Item no. 03-000561	Page 89

Mounting solutions for corrugated and sandwich roof

Further applications



Elevation: Cross-rail south-facing

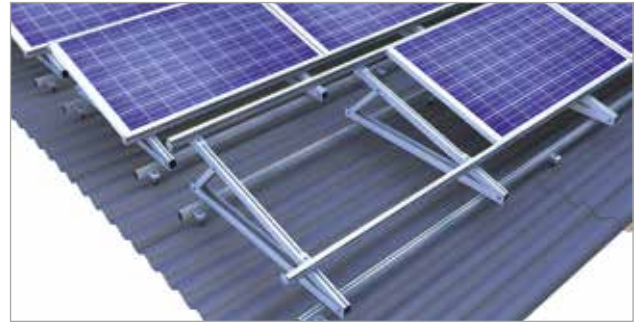

Elevation: South-facing with triangle on east-west roof



Elevation: South-facing with clamping system

Combination matrix for mounting system components

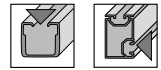

The following table illustrates the possible combinations of profile rails and roof attachments. These combinations apply for both the clamping systems (page 40 et seq.) and the insertion systems (page 44 et seq.).

		PROFILE RAIL			
		 N-RAIL ECO 03-000679	 N-RAIL STANDARD 03-000965	 C-RAIL 47 03-000291	 C-RAIL 71 03-000147
ROOF ATTACHMENT	 Stock screw set HP (for wood) M10 200 mm GPS1 03-000561 ff	✓	✓		
	 Base plate aluminium Stock screw M10 / M12 03-000699 ff	✓	✓		
	 Stock screw bridge short up to 200 mm 03-000446	✓	✓		
	 Stock screw bridge long up to 360 mm 03-000447	✓	✓		
	 Stock screw set HP (for wood) M10 03-000222 ff			✓	✓
	 Stock screw set HP (for wood) M12 03-000211 ff			✓	✓
	 Stock screw set SP (for steel) 8,0-M10 03-000199 ff			✓	✓
	 Stock screw set HP (for wood) 8,4-M10 03-000894 ff			✓	✓

All individual products can be found in chapter 5 from page 86 or on our website: solar-distribution.baywa-re.de/en/



Low installation workload – novotegra
for seamed metal roofs



Mounting solutions for seamed metal roof

Main applications



Clamping system: In portrait on standing seam



Insertion system: In portrait on standing seam



Clamping system: In portrait on round seam



Insertion system: Installation on standing seam in landscape



Clamping system: In portrait on standing seam copper roof

Your benefits

- Seam clamps for standing and round seams as well as profile sheet roofs
- Clamping systems with only three different clamps for all frame heights
- Rail with an integrated cable channel and room for plugs
- Quick mounting with only a handful of components thanks to a rail connection from above
- Insertion systems for module mounting in portrait or in landscape



Single-rail clamping system with modules installed in portrait

PERFECT FOR SEAMED METAL ROOFS

Be it a standing seam roof, a rounded seam roof or a profiled sheet roof, such as a Zambelli RibRoof or Domico GBS: Our novotegra clamping system, which has proven itself over years of service, ensures the reliable, stable and secure attachment of your photovoltaic installation on any seamed metal roof.

With the roof seam clamping technology, our mounting system is attached directly to the roof seam: The load is transferred centric in to the seam. Our clamping system for seamed metal roofs can also be used on standing seam roofs made of copper. They have a high production quality and comprise durable and corrosion-resistant components – perfect for the individual requirements of the photovoltaic installation on site.

Our clamping system is quick and easy to fix to the seamed metal roof. It comprises only three components: the C-rails, the seamed metal and the module clamps. The modules are installed vertically. The module clamps are available in three sizes – and in either blank aluminium or black. Mounting is done comfortably from above. The rails can also be extended with connectors as needed. Our mounting system for seamed metal roofs provides excellent rear ventilation of the modules and – with decent system components and homogenous module fields – attractive aesthetics.

YOUR BENEFITS

- Only a handful of components – entirely pre-assembled
- Quick mounting from above
- The C-rail also acts as a cable channel
- Only three clamps for all frame heights
- Secure, stable and durable
- For all conventional seamed metal and profile sheet roofs
- Also suitable for standing seam roofs made of copper
- Excellent rear ventilation
- Simple, Eurocode-compliant layout with our Solar-Planit online tool



Clamp with saddle for copper standing seam roofs



C-rail connection directly on the seam clamp



Flush closure end clamp with C-rail



CLAMPING SYSTEM

Middle clamp or
end clamp

Page 113



Item no. 03-000302



Item no. 03-000299



Item no. 03-000301



Item no. 03-000298

ATTACHMENT SYSTEM

Connector

Page 103

Item no. 03-000925



Rail

Page 98

Item no. 03-000291



Seam clamp

Page 91

Item no. 03-000219



VA saddle
(only for copper roofs)

Page 91

Item no. 03-000338





Single-rail insertion system with modules installed in portrait

PERFECT AESTHETIC AND HIGH EFFICIENCY – THE INSERTION SYSTEM FOR STANDING SEAM ROOFS

Proven clamping technology on standing seams and elegant system aesthetics thanks to our insertion system – the combination of extended standing seam clamps and proven insertion rails makes it possible.

Whether on a gabled roof or a mono-pitch roof, with our insertion system for standing seam roofs, you can install the modules in portrait or landscape on the roof coverage. You can choose between blank aluminium and black insertion rails – we have both versions ready for you and suitable for all module frame heights.

The design of the standing seam clamp allows for gentle fastening to the standing seam flanging and at the same time for simple direct fastening of the insertion rail with the proven holding bracket on the standing seam clamp. This makes our system efficient in assembly and economical because there is no need for a cross rail. We make sure the system looks good as well: the edge stop forms the closure at the edge of the system and also secures the modules in place.

Fewer components, completely pre-assembled – designed for quick and easy assembly.

YOUR BENEFITS

- Discreet system aesthetics with insertion system
- Proven module insertion technology
- Insertion rails match colour of module frame
- Fewer components – quick assembly
- Cost-optimised single-rail system
- Completely pre-assembled seam clamp with connector for insertion rail
- Clamping technology with clamping points on the seam flanging
- Secure, stable and durable
- Simple, Eurocode-compliant layout with our Solar-Planit online tool



Clamp for insertion system on standing seam roof

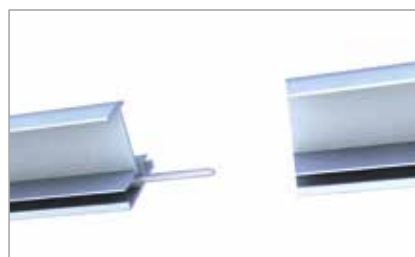

Insertion rail connection



Module security at low roof inclination



INSERTION SYSTEM

Insertion rail

Page 96

Item no. 03-000492



Connector

Page 102

Item no. 03-000647



Edge stop

Page 109

Item no. 03-000691



ATTACHMENT SYSTEM

Roof attachment

Page 91

Item no. 03-001028



3

Flat roof



Minimal ballasting
possible – novotegra for
flat roof south-facing system

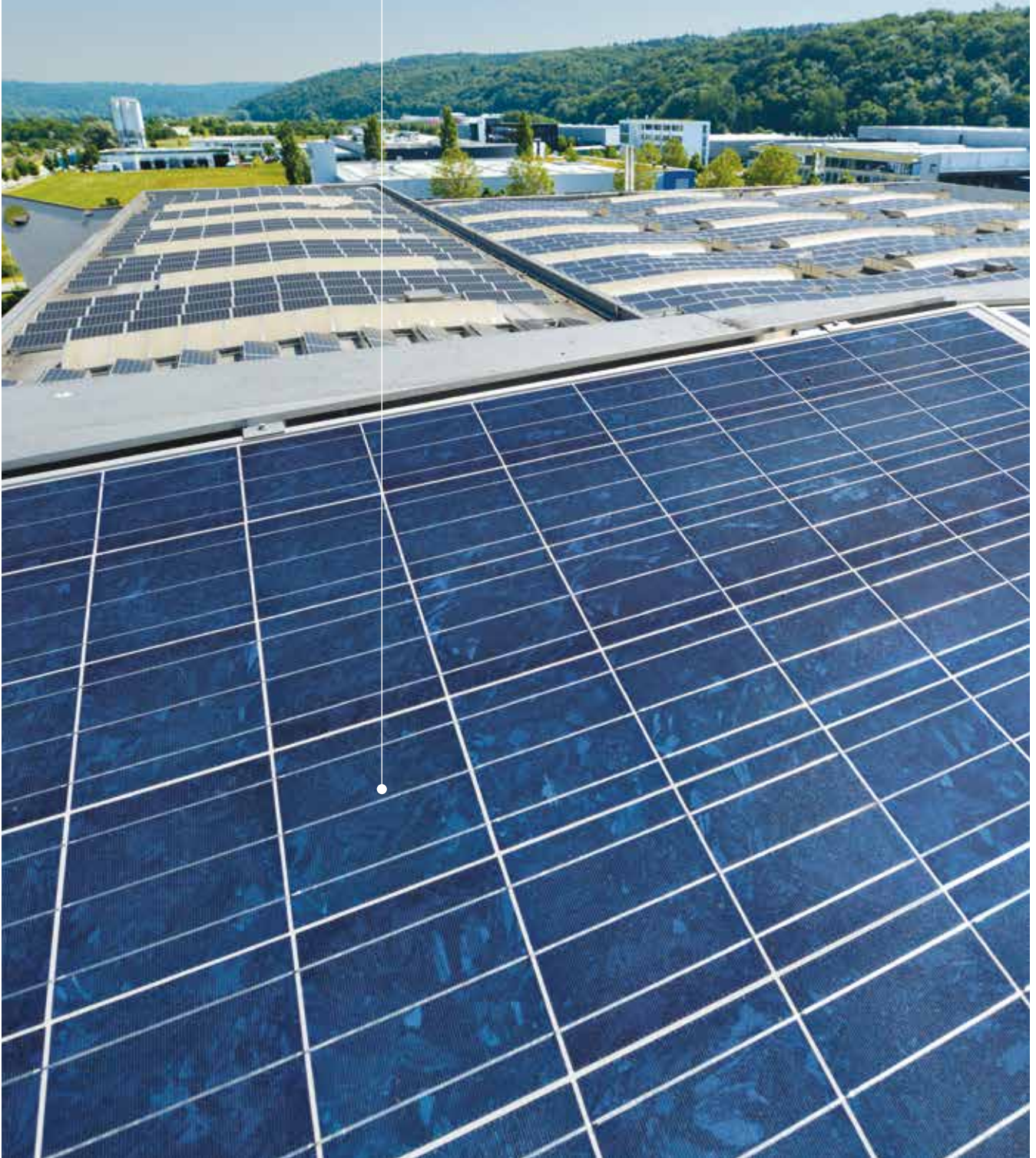

Mounting solutions for flat roof

Main applications



Foil roof: East-West system II



Foil roof: South system closed II



Gravel: East-West system I with cross rail



Gravel: South system I with cross rail



Foil roof: East-West system II with 3. base trough



Foil roof: South system closed II with 3. base trough

Your benefits

- Aerodynamic system tested in a wind tunnel – reliable security!
- Only a handful of components which are quickly and easily assembled – a cost-effective system
- Minimal need for ballasting due to load redistribution through wide base trough with rounded edges
- Alternative solutions with a stable cross-rail system and elevation triangles



Flat roof system east-west II

OUR SOLUTION FOR THE EAST-WEST DIRECTION

With our east-west II mounting system, you can optimise the use of the surface area of your flat roof: Compared to south-facing elevations, you can install nearly twice the module surface area. Electricity production is thus distributed more evenly throughout the entire day. The east-west II mounting system is a very secure and stable system for flat roofs with a pitch of up to 5° – and, what is more, it is quick and easy to assemble.

The mounting system is fixed on the roof with its own weight and, if necessary, ballast stones, although the optimised aerodynamics of our system require little to no ballasting: an advantage for flat roofs with low load reserves.

The mounting system consists of only a few components. The substructure is installed in a modular grid. The base foot and the module support are clicked together, and the module fastened by the short side of the frame. The base trough, which can be used as a cable channel, has rounded edges and a separation layer to protect the roof membrane. The system is installed on foil and bitumen roofs and can also be installed on gravel roofs.

Our various supports allow us to tailor solutions to the specific loads – even with heavy load requirements. Per default, we can subject the east-west II mounting system to loads of 2.4 kN/m², and with a module clamp on the long side, even up to 4.8 kN/m².

YOUR BENEFITS

- Secure, stable and quick to install
- Wind-tunnel tested aerodynamics
- No penetration of the roof membrane
- Minimal ballasting
- Optimal angle of inclination of 13°
- More module surface area possible
- Wide base trough with rounded edges
- Ballast trough for large-format stones
- Double support for heavy loads
- Rail with pads for cross drainage
- Only three clamps for all frame heights
- Simple, Eurocode-compliant layout with our Solar-Planit online tool

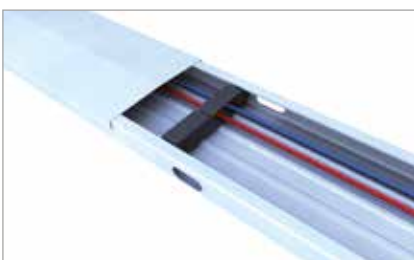

Base rail with cover and cable holder





Base foot in base trough with connector



Wind deflector East-West for roof obstacles



BASIC COMPONENTS

<p>Base trough</p>		<p>Page 100</p>
<p>Connector set base trough</p>		<p>Page 105</p>
<p>Aluminium edge protector self-adhesive</p>		<p>Page 124</p>
<p>Flat roof mounting screw</p>		<p>Page 94</p>
<p>Base foot</p>		<p>Page 117</p>

Item no. 03-000989

Item no. 03-000370

Item no. 03-000407

Item no. 03-000383

Item no. 03-000343

EAST-WEST VARIANT

<p>Module support</p>		<p>Page 117</p>
<p>Ballast redistribution</p>		<p>Page 101</p>
<p>Module bracket</p>		<p>Page 117 / 118</p>

Item no. 03-000442

Item no. 03-000314

Item no. 03-000324

Item no. 03-000326

Item no. 03-000310



Flat roof system closed II

OUR SOLUTION FOR THE SOUTH-FACING DIRECTION

Our "Flat Roof Closed II" system – the perfect solution for the south-facing elevation of your modules on flat roofs with a pitch of up to 5°! We had our system tested by Wacker engineers in a boundary layer wind tunnel with high wind peaks. The result confirms our quality which has proven itself for years: with our flat-roof system, you are choosing unparalleled security and stability.

The closed II system convinces with its quick and easy installation, consists of only a handful of components and click-in system parts – the roof is not punctured during installation. The optimised aerodynamics required little to no ballasting with stones – perfect for your flat roof. This is made possible by our wind deflector which is installed in an overlapping fashion on the closed II elevation and fixed to the supports and rails. This increases the overall stability and ensures optimised load transfer through its attachment to the base rails.

The wide base rail has rounded edges and is pre-assembled with a continuous separation layer or individual pads for cross drainage, as desired. With a suitable cover and cable holder, it can also act as the cable channel for the cables on the base rails. Per default, this mounting system can support loads of up to 2.4 kN/m²; and can be expanded to loads of up to 4.8 kN/m² if necessary.

YOUR BENEFITS

- Secure, stable and quick to install
- Wind-tunnel tested aerodynamics
- No penetration of the roof membrane
- Minimal ballasting
- Load redistribution across the wind deflector and base troughs
- Optimal angle of inclination of 13°
- Roof edge clearance of only 0.5 m
- Wide base trough with rounded edges
- Ballast trough for large-format stones
- Only three clamps for all frame heights
- Simple, Eurocode-compliant layout with our Solar-Planit online tool



Base trough extension



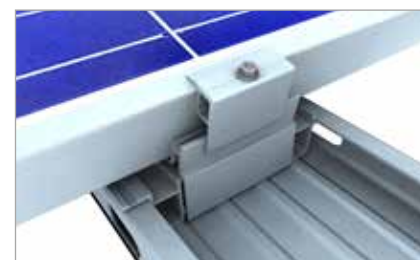

Wind deflector and module support



Module clamp on the long frame side base foot



BASIC COMPONENTS

<p>Base trough</p>		<p>Page 100</p>
<p>Connector set base trough</p>		<p>Page 105</p>
<p>Aluminium edge protector self-adhesive</p>		<p>Page 124</p>
<p>Flat roof mounting screw</p>		<p>Page 94</p>
<p>Base foot</p>		<p>Page 117</p>

Item no. 03-000879

Item no. 03-000370

Item no. 03-000407

Item no. 03-000383

Item no. 03-000343

SOUTH VARIANT

<p>Module support</p>		<p>Page 117</p>
<p>Ballast redistribution</p>		<p>Page 118</p>
<p>Module bracket</p>		<p>Page 117 / 118</p>

Item no. 03-001243

Item no. 03-000331

Item no. 03-000324

Item no. 03-000326

Item no. 03-000310



Flat roof system east-west I for gravel

OUR FLEXIBLE SOLUTION FOR EAST-WEST-FACING SYSTEMS

Do you value flexible assembly and simple ballasting for your flat roof project? Then we have exactly the right solution with our flat roof east-west I system with 13° elevation angle.

With our base trough in the gravel rail version, you use the existing gravel to ballast the PV system. The gravel is simply poured into the 230 x 90 mm gravel rail as ballast. Our base profile is used as a module-bearing rail; it is then fastened flexibly as a cross rail to the bottom gravel rail using thin sheet screws. Reliable, solid and effective – this describes our cross-rail solution for gravel roofs.

The flexible installation means you can also use the east-west I system with the normal base trough with pre-assembled separation layer. Or you can insert the base trough with pads for horizontal drainage. For both base trough types, we have the right support set for you to elevate the modules on the C-rails.

The module bracket set back for connecting to frame holes on the module elevate the module securely in the base profile using form closure. The module bracket set back for clamping the modules are clicked into the C-rails and can be attached to the clamping points provided by the module manufacturer. The C-rail can be used at the same time as a cable channel for the string cables.

YOUR BENEFITS

- More kilowatts per roof surface
- Simple ballasting using existing gravel
- Stability and flexibility thanks to cross system
- Optimal module clamping at assembly holes
- Tested in a wind tunnel
- Optimised 13° elevation for roof inclination up to 5°
- Edge spacing of just 0.5 m possible
- No penetration of the roof membrane
- Can also be used on foil roofs with normal base trough
- C-rail with optional cover as a cable channel for string cables



Module support and C-rail







Base profile fastening to base trough



Module bracket set front



BASIC COMPONENTS

<p>Separation layer</p>		<p>Page 124</p>
<p>Base trough</p>		<p>Page 101</p>
<p>Flat roof mounting screw</p>		<p>Page 94</p>
<p>Base profile</p>		<p>Page 101</p>
<p>Base profile connector</p>		<p>Page 106</p>

EAST-WEST VARIANT

<p>Support</p>		<p>Page 121</p>
<p>Ballast redistribution</p>		<p>Page 98</p>
<p>Rail connector</p>		<p>Page 104</p>
<p>Module bracket</p>		<p>Page 119 / 121</p>

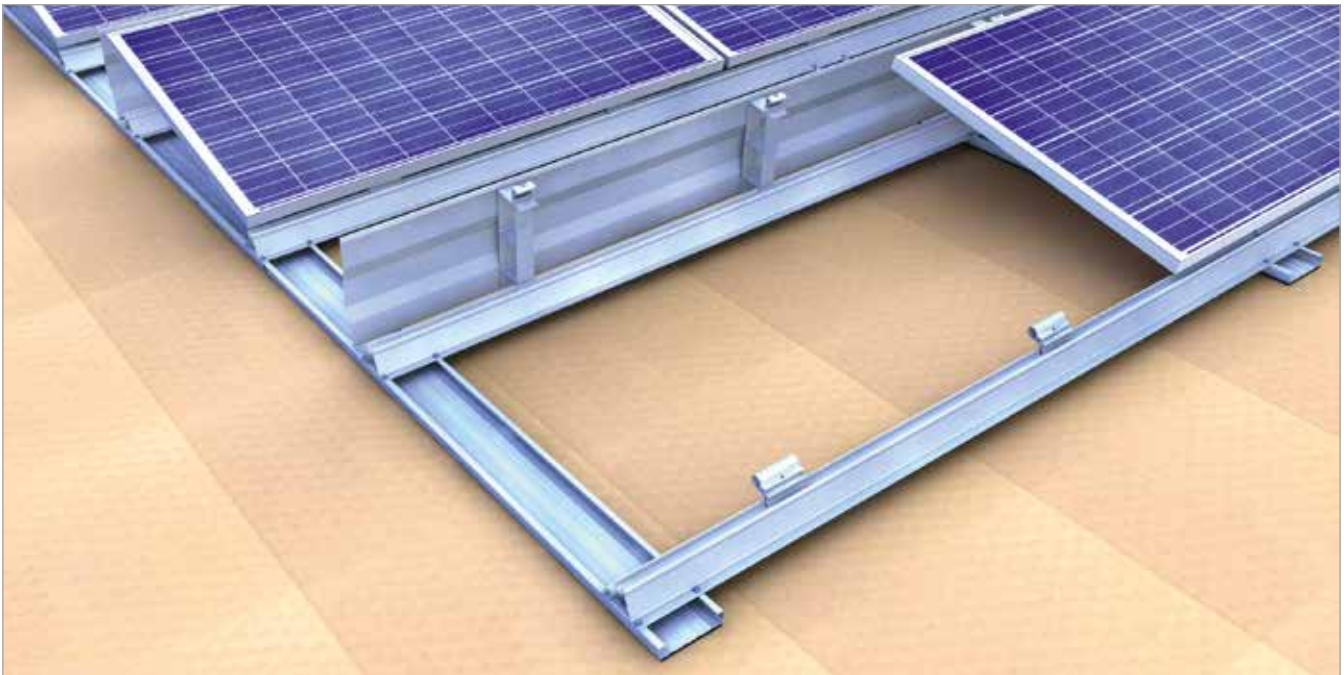

Flat roof system closed I

OUR FLEXIBLE SOLUTION FOR SOUTH-FACING SYSTEMS

Flexible, stable, proven – that's our closed flat roof system I for south-facing roofs! It is easy to mount, versatile and extremely stable. The aerodynamic flat roof system has been tested in the Wacker Ingenieure boundary layer wind tunnel and combines maximum safety with outstanding stability and flexible assembly. Whether it is mounted on a foil or gravel roof, whether snow loads above 2.4 kN/m² or ideal module clamping in 1/4-point are expected – the south system closed I is the ideal solution for demanding flat roof systems.

The substructure is constructed as a cross-rail system with a base trough and module-bearing rail on top. Here, the base trough serves as a base for the ballast and at the same time fastens the module-bearing rails. Our proven base profile is used as a module-bearing rail. Wind and snow loads on the module are safely transferred by the module supports to the base profile. Form closure instead of a screw connection – secure and stable, quick and simple!

The module bracket set front, which is fastened at the frame holes and therefore at the ideal clamping point for the modules, serves as the front bearing on the base profile. The module support set elevates the module, while also being used to support and clamp the module and to fasten the wind deflector.

YOUR BENEFITS

- Tested in a wind tunnel
- Optimised 13° elevation for roof inclination up to 5°
- Edge spacing of just 0.5 m possible
- No penetration of the roof membrane
- Individual adjustment to the roof
- Flexibility thanks to cross system
- Stable cross-rail system
- Can also be used with base trough to fill with gravel
- Optimal module clamping at assembly holes
- Use of proven system components

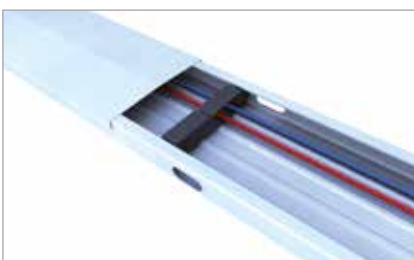

Base rail with cover and cable holder







Module support and wind deflector closed I



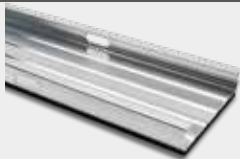
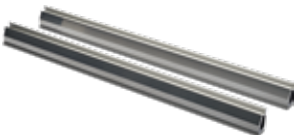

Module bracket set front in base profile



BASIC COMPONENTS

<p>Base trough</p>	<p>Item no. 03-000989</p>		<p>Page 100</p>
<p>Connector set base trough</p>	<p>Item no. 03-000370</p>		<p>Page 105</p>
<p>Aluminium edge protector self-adhesive</p>	<p>Item no. 03-000407</p>		<p>Page 124</p>
<p>Flat roof mounting screw</p>	<p>Item no. 03-000383</p>		<p>Page 94</p>
<p>Base profile</p>	<p>Item no. 03-000193</p>		<p>Page 101</p>
<p>Base profile connector</p>	<p>Item no. 03-000021</p>		<p>Page 106</p>

SOUTH VARIANT

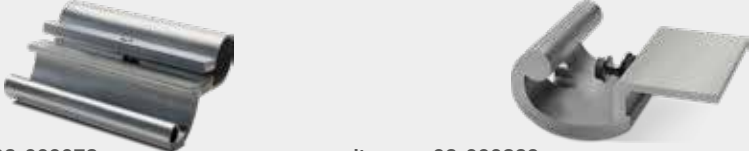
<p>Module support</p>	<p>Item no. 03-000330</p>		<p>Page 120</p>
<p>Wind deflector</p>	<p>Item no. 03-000013</p>		<p>Page 121</p>
<p>Module bracket</p>	<p>Item no. 03-000078</p>		<p>Page 119</p>

4

Custom solutions



Using facade surfaces optimally

CLEAR ADDED VALUE FOR YOUR FACADE

With the novotegra facade mounting system, you use the exterior wall of a building to generate electricity: The photovoltaic installation is hung vertically in front of the facade – but it does not touch the building and is well-ventilated from behind. Our facade mounting system is installed on a solid exterior wall out of, for example, brick, stone or concrete – and exclusively on cold facades, meaning on walls without external insulation.

Regardless of whether the exterior wall is on an industrial building or a single-family home: with our photovoltaic mounting system, we create modern, highly-aesthetic facades which give buildings visual added value. All visible mounting system components are available in blank aluminium or black anodised and can be combined with blue or black modules.

The modules are placed in the rail with their entire frame length and held in place gently, firmly and securely. The insertion rails make module mounting quick and easy, even when installed vertically. The small handful of individual components and pre-assembled parts make assembly even easier. With the novotegra facade mounting system, you can mount all framed modules in portrait as well as landscape.

Furthermore you can complete your facade system on all sides with a perforated sheet cladding that prevents birds and small animals from accessing the installation but still ensures excellent rear ventilation.

YOUR BENEFITS

- The facade is used to generate electricity
- Creates modern, visually attractive facades
- Flexible system size:
From a single module to the entire facade surface
- A construction with excellent rear ventilation which hangs in front of the building but does not touch it
- For solid exterior walls
- For cold facades without insulation



Few components - simple and fast installation



Very good rear ventilation of the modules



Dowels with technical approval



INSERTION SYSTEM

Insertion rail	 Item no. 03-000540	Page 96
Connector	 Item no. 03-000499	Page 102
Edge stop	 Item no. 03-000693	Page 109

ATTACHMENT SYSTEM

Cross-rail connector	 Item no. 03-000409	Page 107
Slip guard	 Item no. 03-000404	Page 123
Socket insertion rail	 Item no. 03-000581	Page 122
Perforated sheet	 Item no. 03-000549	Page 123
Adapter plate	 Item no. 03-000385	Page 123
Connector perforated sheet	 Item no. 03-000497	Page 123

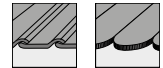

The in-roof system solution – PV generator and roof coverage in one

INSTEAD OF TILES AND CO: THE INSERTION SYSTEM

It simply looks great: With the Arres in-roof system for mounting photovoltaic modules, your roof turns into an aesthetic, homogeneous surface. The photovoltaic installation replaces the roof covering on the entire roof surface – or only in selected areas of the roof. Easy-to-handle blind modules and visually matching, high-quality skylights complete the in-roof system; all components are manufactured in black. Our in-roof mounting system ensures security and a high production quality and durability. It is suitable for any roof and is easy and – compared to other in-roof systems on the market – very quick to install.

The photovoltaic modules are mounted directly on the roof battens without hooks. The special module frames developed specifically for the in-roof system come from Switzerland, where the modules and frames are assembled. Our in-roof system fulfills the same water-resistance requirements as roof tiles – which has been confirmed through analogue tests by the test and inspection institute in Sursee. It can be used for loads of up to 5.4 kN/m^2 ; with heavier loads possible if additional supportive roof battens are used. The modules are mounted horizontally and their frames are scaled over one another.

Stable blind modules, which can easily be fit using a circular saw or a jigsaw, ensure a closed roof surface and an aesthetic result. A snow guard can also be integrated with snow guard blind modules. The visually matching skylights developed for the Arres in-roof system are available in various sizes and as a double window. The high-quality energy-saving windows, which are equipped with a supportive gas pressure spring, comprise a wood-glass construction. Blind modules and windows can be seamlessly integrated in the module grid.

For our in-roof mounting system we offer modules in three different performance classes – to meet all customer needs. The selection is yours.

YOUR BENEFITS

- Highly homogenous and aesthetic surface
- Flexible thanks to various module types
- Visually attractive integration of obstacles with blind modules
- Visually matching high-quality skylights
- Quick mounting – no hooks
- High-quality production and durability
- Excellent rear ventilation of the module
- Snow guard for blind module

novotegra Facade system
Modern, attractive and efficient.

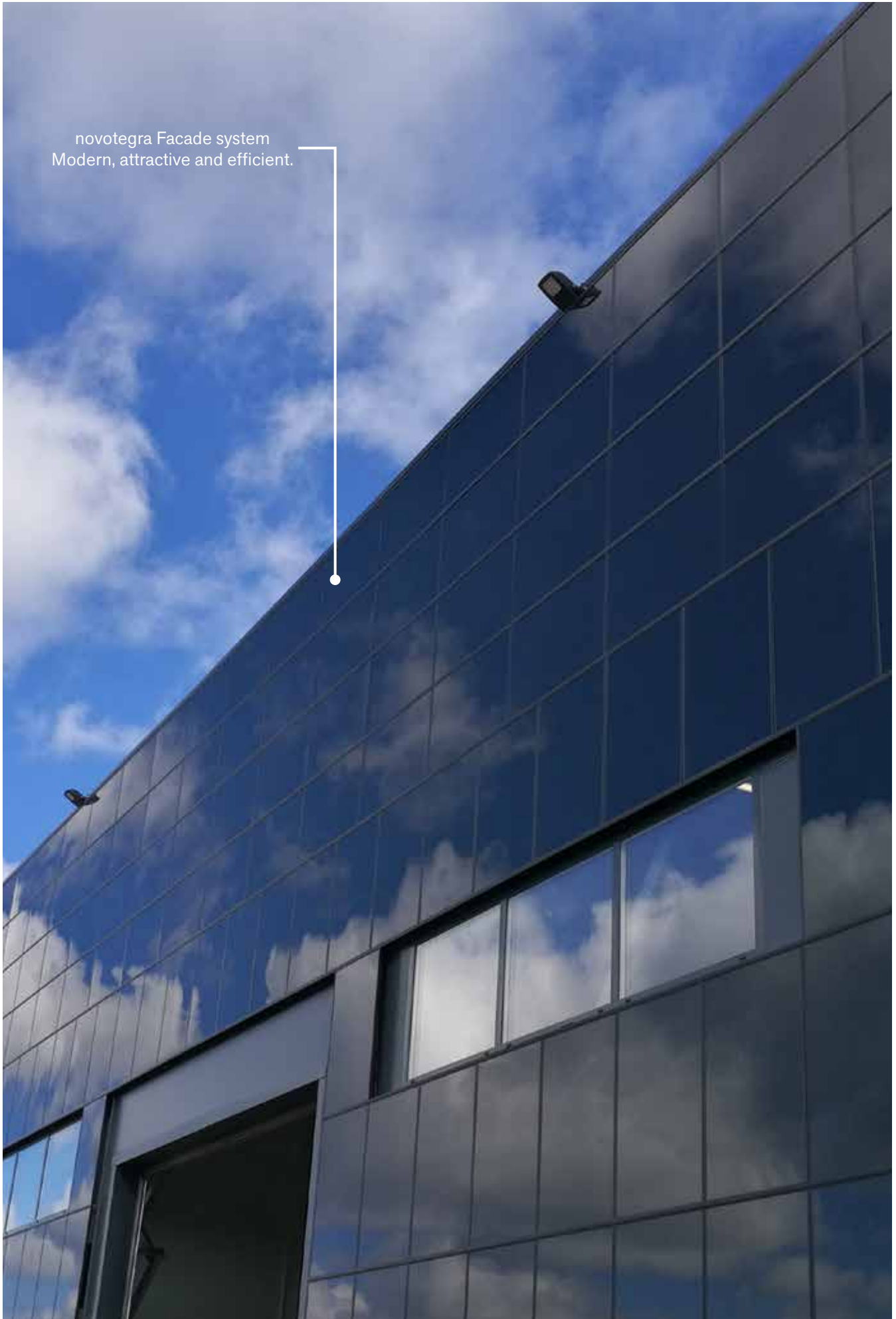

5

Single items

Roof hook tile roof and beavertail



Roof hooks for mounting C-rails as vertical and horizontal rails, optimised for narrow rafters, rail-roof hook connection height-adjustable up to 30 mm, roof hook-base profile connection height-adjustable for 18 – 30 mm, 24 – 30 mm or 31 – 40 mm batten, for tile overlap up to approx. 80 mm.

Item no.	Designation	a in mm	b in mm	c in mm	Material
03-001109	Flex roof hook set 18 M10	120	80	23 – 47	Alu / A2SS
03-001149	Flex roof hook set 30 M10	120	80	40 – 52	Alu / A2SS
03-001151	Flex roof hook set 40 M10	120	80	50 – 62	Alu / A2SS

Double roof hook tile roof and beavertail



Roof hooks for mounting C-rails as horizontal rails, optimised for narrow rafters and heavy loads, rail-roof hook connection height-adjustable up to 30 mm, roof hook-base profile connection height-adjustable for 24 – 30 mm or 31 – 40 mm batten, for tile overlap up to approx. 80 mm.

Item no.	Designation	a in mm	b in mm	c in mm	Material
03-001150	Flex double roof hook set 30 M10	230	80	40 – 52	Alu / A2SS
03-001152	Flex double roof hook set 40 M10	230	80	50 – 62	Alu / A2SS

Roof hook tile roof



Roof hooks for mounting C-rails as vertical and horizontal rails, rail-roof hook connection height-adjustable up to 35 mm, roof hook-base profile connection height-adjustable for 24 – 30 mm or 31 – 40 mm batten, for tile overlap up to approx. 80 mm.

Item no.	Designation	a in mm	b in mm	c in mm	Material
03-000254	Roof hook set ZD 30 M12	155	126	43 – 49	Alu / A2SS
03-000256	Roof hook set ZD 40 M12	155	126	57 – 63	Alu / A2SS

Double roof hook tile roof



Roof hooks for mounting C-rails as horizontal rails, optimised for heavy loads, rail-roof hook connection height-adjustable up to 35 mm, roof hook-base profile connection height-adjustable for 24 – 30 mm or 31 – 40 mm batten, for tile overlap up to approx. 80 mm.

Item no.	Designation	a in mm	b in mm	c in mm	Material
03-000255	Double roof hook set ZD 30 M12	245	125	43 – 49	Alu / A2SS
03-000257	Double roof hook set ZD 40 M12	245	125	57 – 63	Alu / A2SS

Roof hook beavertail



Roof hooks for mounting C-rails as vertical and horizontal rails on roofs with beavertail tiles, rail-roof hook connection height-adjustable up to 35 mm, roof hook-base profile connection height-adjustable for 24 – 30 mm batten, for beavertail double tile formation.

Item no.	Designation	a in mm	b in mm	c in mm	Material
03-000258	Roof hook set BS 30 M12	160	95	42 – 48	Alu / A2SS

Double roof hook beavertail



Roof hooks for mounting C-rails as horizontal rails on roofs with beavertail tiles, optimised for heavy loads, rail-roof hook connection height-adjustable up to 35 mm, roof hook-base profile connection height-adjustable for 24 – 30 mm batten, for beavertail double tile formation.

Item no.	Designation	a in mm	b in mm	c in mm	Material
03-000267	Double Roof hook set BS 30 M12	260	95	42 – 48	Alu / A2SS

Roof hook tile roof

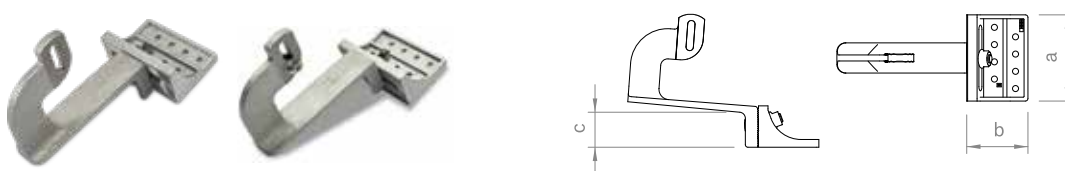

Roof hooks for mounting N-rails as vertical rails, rail-roof hook connection height-adjustable in slot 8.5 × 35 mm up to 26 mm, brackets on both sides 32.5 mm, in height 15 mm in slot adjustable, tile overlap up to approx. 100 mm for 30 mm roof battens, optionally pre-assembled with slot bolt M8.

Item no.	Designation	a in mm	b in mm	c in mm	Material
03-000756	Roof hook adjustable 633 vertical	100	70	41 – 56	Alu cast
03-000949	Roof hook set adjustable 633 vertical M8	100	70	41 – 56	Alu cast / A2SS

Roof hook tile roof

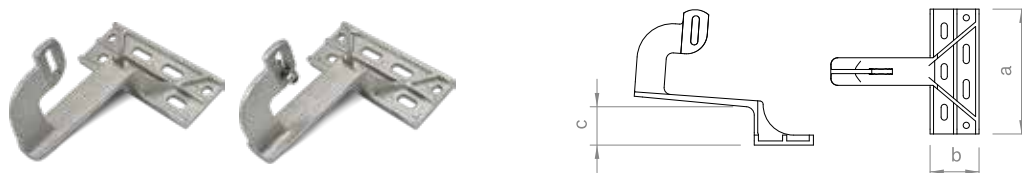

Roof hooks for mounting N-rails as vertical rails, rail-roof hook connection height-adjustable in slot 8.5 × 35 mm with fluting up to 26 mm, for tile overlap up to approx. 100 mm and 30 mm roof battens, optionally pre-assembled with slot bolt M8.

Item no.	Designation	a in mm	b in mm	c in mm	Material
03-000731	Roof hook ZD 533 vertical	181	71	46	Alu cast
03-000612	Roof hook set ZD 533 vertical M8	181	71	46	Alu cast / A2SS

Roof hook tile roof



Roof hooks for mounting N-rails as horizontal rails, rail-roof hook connection height-adjustable in slot 8.5 × 35 mm with fluting up to 26 mm, for tile overlap up to approx. 100 mm and 30 mm roof battens, optionally pre-assembled with Slot bolt M8.

Item no.	Designation	a in mm	b in mm	c in mm	Material
03-000611	Roof hook ZD 544 horizontal	181	71	46	Alu cast
03-000613	Roof hook set ZD 544 horizontal M8	181	71	46	Alu cast / A2SS

Roof hook beavertail

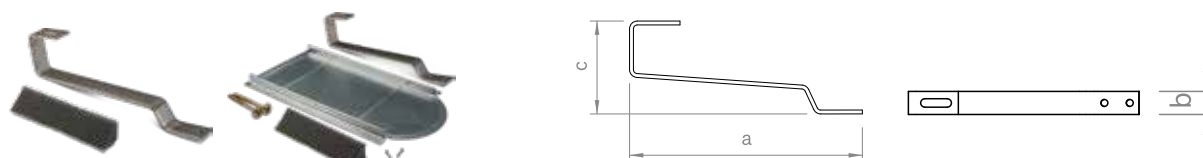

Roof hooks for mounting N-rails as vertical and horizontal rails on roofs with beavertail tiles, rail-roof hook connection with L-adapter in slot 11 × 41 mm, for 24 mm roof battens. As a set with underlay plate, screws and sealing wedge, for beavertail double tile formation.

Item no.	Designation	a in mm	b in mm	c in mm	Material
03-000410	Roof hook BS C-shape A2SS	300	30	120	A2SS
03-000411	Roof hook set BS C-shape A2SS with sheet	300	30	120	A2SS / St. galv.

Roof hook slate

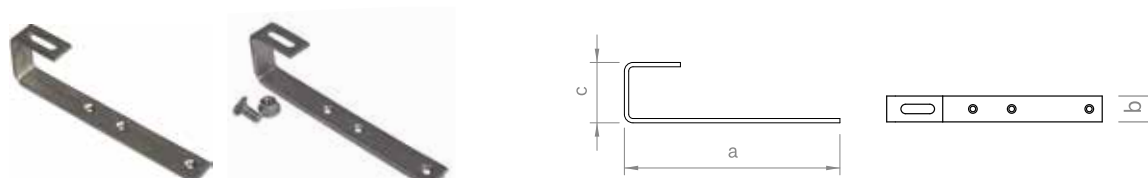

Roof hooks for mounting N-rails or C-rails as vertical and horizontal rails on roofs with slate or shingle roofing, rail-roof hook connection with L-adapter in slot 11 × 41 mm or as a set with round-head screw M10, with flat foot area.

Item no.	Designation	a in mm	b in mm	c in mm	Material
03-000694	Roof hook S C-shape A2SS	250	30	70	A2SS
03-001219	Roof hook set S C-shape A2SS M10	250	30	70	A2SS

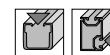

Stock screws (for wood)

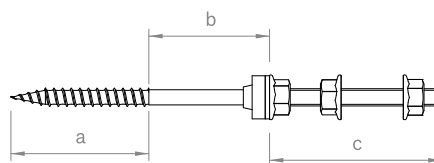

Stock screw for timber purlins with hexagon drive 7 AF or 9 AF, for mounting C-rails, base plates or stock screw bridges, with EPDM seal and 18 AF locking nuts.

Item no.	Designation	a in mm	b in mm	c in mm	Material
03-000222	Stock screw set (for wood) M10 200 mm	75	25	100	A2SS/EPDM
03-000223	Stock screw set (for wood) M10 250 mm	75	75	100	A2SS/EPDM
03-000224	Stock screw set (for wood) M10 300 mm	75	75	150	A2SS/EPDM
03-000211	Stock screw set (for wood) M12 200 mm	75	25	100	A2SS/EPDM
03-000210	Stock screw set (for wood) M12 250 mm	75	75	100	A2SS/EPDM
03-000216	Stock screw set (for wood) M12 300 mm	75	75	150	A2SS/EPDM

Stock screws N-rail (for wood)

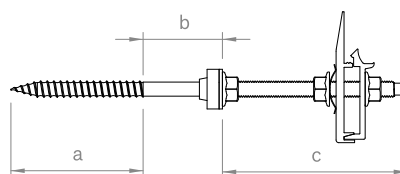

Stock screw for timber purlins with hexagon drive 7 AF or 9 AF, base plate with click mechanism for mounting N-rails, pre-assembled with EPDM seal and 17 AF or 18 AF locking nuts.

Item no.	Designation	a in mm	b in mm	c in mm	Material
03-000561	Stock screw set (for wood) M10 200mm GPS1	70	10	120	A2SS/Alu/EPDM
03-000562	Stock screw set (for wood) M12 200mm GPS1	75	15	110	A2SS/Alu/EPDM
03-000563	Stock screw set (for wood) M12 250mm GPS1	90	10	150	A2SS/Alu/EPDM
03-000564	Stock screw set (for wood) M12 300mm GPS1	100	40	160	A2SS/Alu/EPDM

Stock screws (for wood)

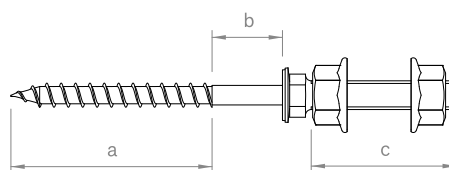

Stock screw for timber purlins with hexagon drive 5 AF, for mounting C-rails, base plates or stock screw bridges, with 18 AF locking nuts, combinable with EPDM round seal d = 25 mm.

Item no.	Designation	a in mm	b in mm	c in mm	Material
03-000894	Stock screw set (for wood) 8.4-M10 160mm	70	10	70	A2SS
03-000895	Stock screw set (for wood) 8.4-M10 190mm	90	20	70	A2SS
03-000940	Stock screw set (for wood) 8.4-M10 210mm	100	30	70	A2SS
03-000941	Stock screw set (for wood) 8.4-M10 240mm	120	40	70	A2SS
03-000942	Stock screw set (for wood) 8.4-M10 260mm	130	50	70	A2SS



Stock screws (for steel)



Stock screw for steel purlins with hexagon drive 5 AF, for mounting C-rails, base plates or stock screw bridges, with 18 AF locking nuts, combinable with EPDM round seal $d = 25$ mm.

Item no.	Designation	a in mm	b in mm	c in mm	Material
03-000199	Stock screw set (for steel) 8.0-M10 140 mm	65	10	50	A2SS
03-000202	Stock screw set (for steel) 8.0-M10 185 mm	65	55	50	A2SS
03-000203	Stock screw set (for steel) 8.0-M10 220 mm	65	90	50	A2SS
03-000943	Stock screw set (for steel) 8.0-M10 260 mm	65	130	50	A2SS

Base plates for stock screw

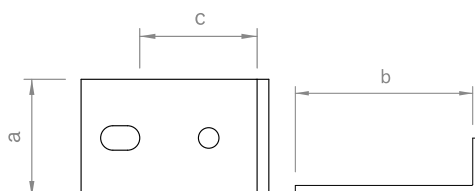

Base plate for stock screws with slot 20×10.5 or 20×12.5 mm, for mounting N-rails with slot bolts or slot nuts.

Item no.	Designation	a in mm	b in mm	c in mm	Material
03-000597	Base plate Alu for stock screw M10	60	90	60	Alu
03-000699	Base plate Alu for stock screw M12	60	90	60	Alu

Stock screw bridges

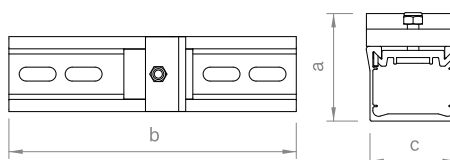

Stock screw bridge two stock screws with slots 25×12 mm, adjustable slides for variable positioning of mounting rails, for raised bead intervals of 110–210 mm or 170–350 mm, completely pre-assembled.

Item no.	Designation	a in mm	b in mm	c in mm	Material
03-000446	Stock screw bridge short up to 220 mm	75	250	65	Alu / A2SS
03-000447	Stock screw bridge long up to 360 mm	75	390	65	Alu / A2SS

Standing seam clamps



Clamp with grub screw for standing seam roofs and an 18 AF locking nut for fixing C-rails, optionally with stainless steel saddle for mounting on copper roofs.

Item no.	Designation	a in mm	b in mm	c in mm	Material
03-000219	Standing seam clamp set M8	7.4	30	17	Alu / A2SS
03-000369	Standing seam clamp set M8 for copper	7.4	30	17	Alu / A2SS

Standing seam clamp insertion system

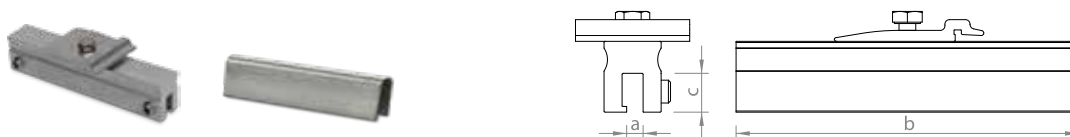

Clamp with grub screws for standing seam roofs, grub screw with hexagon AF 5 drive, pre-assembled with cross rail connector IR and hexagon screw AF 13 for direct fixing of insertion rails. An additional stainless steel saddle is required for mounting on copper roofs.

Item no.	Designation	a in mm	b in mm	c in mm	Material
03-001028	Standing seam clamp set 150 M8 IR	7.4	150	17	Alu / A2SS
03-001135	A2SS-saddle for standing seam clamp 150	7.4	150	17	A2SS

Rounded seam clamp



Clamp with grub screw and cylinder head screw with hexagon drive AF 5 for round seam roofs and an 18 AF locking nut for fixing C-rails.

Item no.	Designation	a in mm	b in mm	c in mm	Material
03-001069	Rounded seam clamp set M8	24	30	36	Alu / A2SS

Profiled metal sheet clamp for Zambelli and Domico metal sheets



Clamp for Zambelli RibRoof 465 or Domico GBS metal profile roofs, with two grub screws for attaching the clamp to the profile sheet as well as an 18 AF locking nut for fixing C-rails, an additional stainless steel saddle is required for sheet thickness ≤ 0.7 mm.

Item no.	Designation	a in mm	b in mm	c in mm	Material
03-001059	Profiled metal sheet clamp set ZD M8	18.8	30	26	Alu / A2SS
03-000198	A2SS-saddle f. profiled metal sheet clamp	16	30	26	A2SS

Profiled metal sheet clamp for Zambelli metal sheets

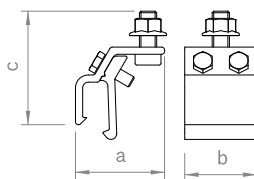

Clamp for Zambelli RibRoof 500 metal profile roofs, with two screws for attaching the clamp to the profile sheet with 13 AF hexagon drives as well as an 18 AF locking nut for fixing C-rails.

Item no.	Designation	a in mm	b in mm	c in mm	Material
03-000201	Profiled metal sheet clamp for Zambelli metal sheets	62	50	80	Alu / A2SS

Trapezoidal sheet brackets

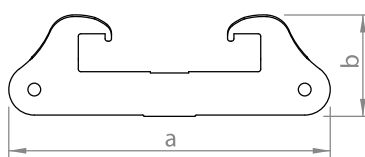

Bracket with EPDM seal for fixing on the trapezoidal sheet, with two thin sheet screws with 8 AF hexagon drive, for bead heights from 25 mm or 35 mm, for framed or frameless module insertion rails.

Item no.	Designation	a in mm	b in mm	c in mm	Material
03-000459	Trapezoidal sheet bracket IR set 40 × 126 mm	126	40		A2SS
03-000451	Trapezoidal sheet bracket IR FL set 45 × 141 mm	141	45		A2SS

Roof hook mounting screws

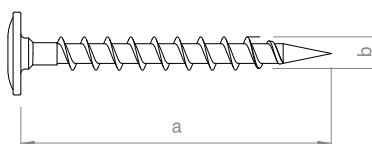
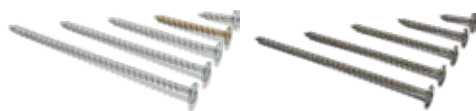

6mm wood screw with flange head and Torx drive 25, can be used for various roof hooks.

Item no.	Designation	a in mm	b in mm	c in mm	Material
03-000268	Roof hook mounting screw 6 × 30	30	6		St. galv.
03-000269	Roof hook mounting screw 6 × 60	60	6		St. galv.
03-000271	Roof hook mounting screw 6 × 90	90	6		St. galv.
03-000272	Roof hook mounting screw 6 × 120	120	6		St. galv.
03-000273	Roof hook mounting screw 6 × 150	150	6		St. galv.
03-000270	Roof hook mounting screw 6 × 30 A2SS	30	6		A2SS
03-000274	Roof hook mounting screw 6 × 60 A2SS	60	6		A2SS
03-000278	Roof hook mounting screw 6 × 90 A2SS	90	6		A2SS
03-000279	Roof hook mounting screw 6 × 120 A2SS	120	6		A2SS
03-000280	Roof hook mounting screw 6 × 150 A2SS	150	6		A2SS



Roof hook mounting screws

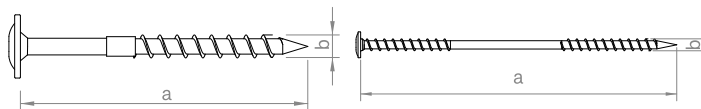

8 mm wood screw with flange head and Torx drive 40, can be used for various roof hooks, with underhead thread for lengths longer than 180 mm.

Item no.	Designation	a in mm	b in mm	c in mm	Material
03-000281	Roof hook mounting screw 8 × 100	100	8		St. galv.
03-000282	Roof hook mounting screw 8 × 140	140	8		St. galv.
03-000283	Roof hook mounting screw 8 × 180	180	8		St. galv.
03-000303	Roof hook mounting screw 8 × 220	220	8		St. galv.
03-000304	Roof hook mounting screw 8 × 260	260	8		St. galv.
03-000305	Roof hook mounting screw 8 × 300	300	8		St. galv.
03-000306	Roof hook mounting screw 8 × 340	340	8		St. galv.



Roof hook S C-shape mounting screws

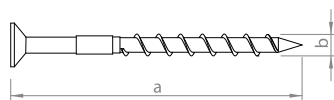

6mm wood screw with countersunk head and AW 30 drive, can be used for roof hooks S C-shape.

Item no.	Designation	a in mm	b in mm	c in mm	Material
03-000486	Roof hook mounting screw 6x80 countersunk head	80	6		St. galv.

Direct mounting screws trapezoidal sheet

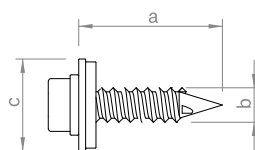

Thin sheet screw for chipless attachment of short rails on the trapezoidal sheet, with 16 mm or 11 mm sealing washer depending on the fixing variation on the raised bead, 8 AF hexagon drive.

Item no.	Designation	a in mm	b in mm	c in mm	Material
03-000880	Trapez. mounting screw cl 6.0x25 E16	25	6	16	A2SS
03-000893	Trapez. mounting screw cl 5.5x25 E11	25	5.5	11	A2SS

Direct mounting set trapezoidal sheet

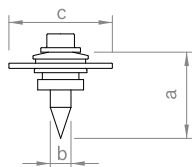

Mounting set for chipless fixing of C-rails on the trapezoidal sheet, pre-assembled thin sheet screw with washer and EPDM seal, 8 AF hexagon drive.

Item no.	Designation	a in mm	b in mm	c in mm	Material
03-000197	C-rail direct mounting set cl	25	6	30	A2SS/EPDM

Direct mounting set trapezoidal sheet

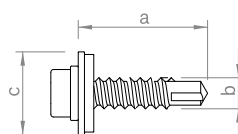

Mounting set consisting of 2 self-drilling screws with 8 AF hexagon drive and an EPDM sealant strip 130x45 mm for fixing base profiles on the trapezoidal sheet.

Item no.	Designation	a in mm	b in mm	c in mm	Material
03-000062	Direct base profile mounting set	25	6	16	A2SS/EPDM

Indirect mounting set base profile

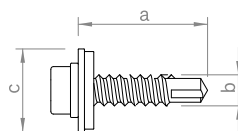

Mounting set consisting of 4 self-drilling screws with 8 AF hexagon drive for fixing the base profile on the C-rail.

Item no.	Designation	a in mm	b in mm	c in mm	Material
03-000065	Indirect mounting set for base profile	25	6	16	A2SS

Flat roof mounting screws

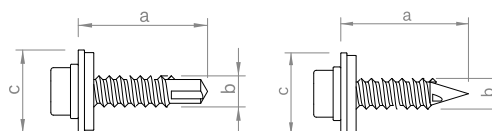

Self-drilling screw or thin sheet screw with 8 AF hexagon drive for connecting flat roof components.

Item no.	Designation	a in mm	b in mm	c in mm	Material
03-000132	Flat roof mounting screw	25	6	16	A2SS
03-000383	Flat roof mounting screw cl 5.5	25	5.5	16	A2SS

Fixing anchor mounting triangle



Stainless steel anchor with an 18 AF locking nut for cracked and uncracked concrete, fixing height of 15–35 or 50–70 mm, total dowel length of 95 or 130 mm, for fixing of mounting triangles.

Item no.	Designation	a in mm	b in mm	c in mm	Material
03-000968	Fixing anchor 15-35 95 mm A4SS for concrete	95	10		A2SS
03-000592	Fixing anchor 50-70 130 mm A4SS for concrete	130	10		A2SS



Insertion rails framed modules

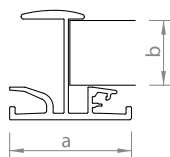

Insertion rail for inserting framed modules with a frame height of 30 - 50 mm, available in blank or black anodised variations.

Item no.	Designation	a in mm	b in mm	c in mm	Material
03-001233	Insertion rail 30 6.00 m	56	30		Alu
03-001146	Insertion rail 32 6.00 m	56	32		Alu
03-000720	Insertion rail 33 6.00 m	56	33		Alu
03-000489	Insertion rail 35 6.00 m	56	35		Alu
03-000522	Insertion rail 36 6.00 m	56	36		Alu
03-000491	Insertion rail 38 6.00 m	56	38		Alu
03-000492	Insertion rail 40 6.00 m	56	40		Alu
03-000515	Insertion rail 41 6.00 m	56	41		Alu
03-000516	Insertion rail 42 6.00 m	56	42		Alu
03-000962	Insertion rail 43 6.00 m	56	43		Alu
03-000517	Insertion rail 45 6.00 m	56	45		Alu
03-000518	Insertion rail 46 6.00 m	56	46		Alu
03-000519	Insertion rail 50 6.00 m	56	50		Alu
03-001234	Insertion rail 30 6.00 m black	56	30		Alu
03-001147	Insertion rail 32 6.00 m black	56	32		Alu
03-000721	Insertion rail 33 6.00 m black	56	33		Alu
03-000521	Insertion rail 35 6.00 m black	56	35		Alu
03-000490	Insertion rail 36 6.00 m black	56	36		Alu
03-000539	Insertion rail 38 6.00 m black	56	38		Alu
03-000540	Insertion rail 40 6.00 m black	56	40		Alu
03-000541	Insertion rail 41 6.00 m black	56	41		Alu
03-000542	Insertion rail 42 6.00 m black	56	42		Alu
03-000543	Insertion rail 43 6.00 m black	56	43		Alu
03-000544	Insertion rail 45 6.00 m black	56	45		Alu
03-000545	Insertion rail 46 6.00 m black	56	46		Alu
03-000963	Insertion rail 50 6.00 m black	56	50		Alu



Insertion rail frameless modules

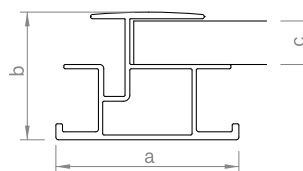

Insertion rail for inserting frameless modules with a glass thickness of approx. 7 mm, EPDM T-pieces are also required for securing laminated modules.

Item no.	Designation	a in mm	b in mm	c in mm	Material
03-000626	Insertion rail FL 6.05 m	69	48	17	Alu

Insertion rails plus snowguard

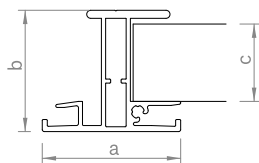

Insertion rail for inserting framed modules with a frame height of 35 mm or 40 mm for heavy snow loads, with the option of attaching a snow guard system.

Item no.	Designation	a in mm	b in mm	c in mm	Material
03-000973	Insertion rail Plus 35 6.00 m	69	55	35	Alu
03-000624	Insertion rail Plus 40 6.00 m	69	60	40	Alu

Support rail module insertion system

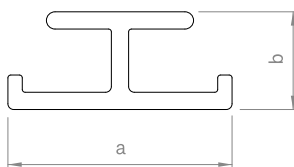

Support rail to brace modules between the insertion rails of a module row in case of heavy snow loads.

Item no.	Designation	a in mm	b in mm	c in mm	Material
03-000555	Support rail IR 6.00 m	39	17		Alu

Snowguard insertion system

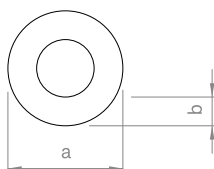

Round pipe in combination with the mounting set snowguard for use on insertion rail Plus as a snow stop system.

Item no.	Designation	a in mm	b in mm	c in mm	Material
03-000406	Snowguard IR 20x5 Alu round pipe 6.00 m	20	5		Alu
03-000408	Snowguard IR 20x5 Alu round pipe 0.80 m	20	5		Alu



C-rails

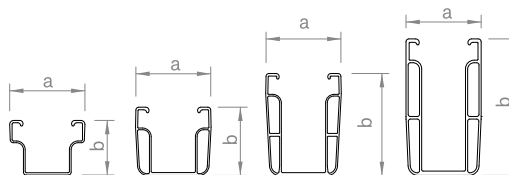

Mounting rail with cable channel, for use as a module support rail in clamping systems or as a cross rail, available in different dimensions for various spans and loads depending on structural requirements, rail bottom with slots 75x15mm in 100mm grid for easy fixing from above.

Item no.	Designation	a in mm	b in mm	c in mm	Material
03-001113	C-rail 38-1,6 2.10m	52	38		Alu
03-001074	C-rail 38-1,6 6.12m	52	38		Alu
03-000882	C-rail 47-2 2.10m	52	47		Alu
03-000293	C-rail 47-2 3.06m	52	47		Alu
03-000292	C-rail 47-2 4.20m	52	47		Alu
03-000291	C-rail 47-2 6.12m	52	47		Alu
03-000147	C-rail 71-2 6.12m	52	71		Alu
03-000025	C-rail 95-3 6.12m	52	95		Alu



N-rails

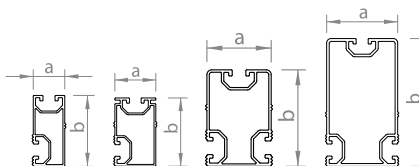

Mounting rail with groove, for use as a module support rail in clamping systems or as a cross rail, available in different dimensions for various spans and loads depending on structural requirements, side groove with fluting for easy fixing from the side.

Item no.	Designation	a in mm	b in mm	c in mm	Material
03-000679	N-rail Eco 22x50 6.00m	22	50		Alu
03-000965	N-rail Standard 20x50 6.00m	30	50		Alu
03-000680	N-rail Premium 40x60 6.00m	40	60		Alu
03-000681	N-rail L 50x90 6.00m	50	90		Alu

Short rails trapezoidal module landscape

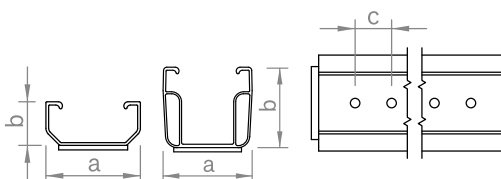

Short rail with 5.2mm perforation and pre-assembled sealant strip for mounting modules in landscape on trapezoidal sheet. Chipless mounting is accomplished using the trapezoidal sheet mounting screw.

Item no.	Designation	a in mm	b in mm	c in mm	Material
03-000841	Short rail C24 with EPDM 125mm	52	24	20	Alu/EPDM
03-001108	Short rail C47 with EPDM 200mm	52	47	20	Alu/EPDM

Short rails corrugated module landscape

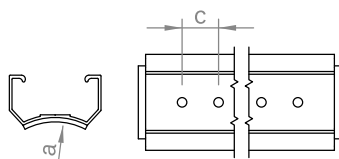

Short rail with 5.2 mm perforation and pre-assembled sealant strip for mounting modules in landscape on corrugated sheet, radius 39.4 mm. Chipless mounting is accomplished using the trapezoidal sheet mounting screw.

Item no.	Designation	a in mm	b in mm	c in mm	Material
03-001223	Short rail C33 R39.4 with EPDM 125 mm	39.4	33	20	Alu/EPDM

Short rail trapezoidal and corrugated module portrait

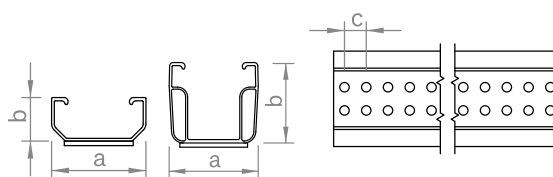

Short rail with 5.2 mm perforation and pre-assembled sealant strip for mounting modules in portrait on trapezoidal or corrugated sheet. Chipless mounting is accomplished using the trapezoidal sheet mounting screw.

Item no.	Designation	a in mm	b in mm	c in mm	Material
03-001081	Short rail C24 with EPDM 385 mm	52	24	12	Alu/EPDM
03-000873	Short rail C47 with EPDM 385 mm	52	47	12	Alu/EPDM

Elevation profile pairs

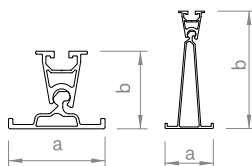

Articulated jointed rail pairs as foot and head rails, for variable module elevation at an angle of approx. 3 – 18° by combining two rail pairs.

Item no.	Designation	a in mm	b in mm	c in mm	Material
03-000646	Elevation profile pair H45 6.00 m	56	45		Alu
03-000470	Elevation profile pair H136 6.00 m	56	136		Alu

Base troughs flat roof

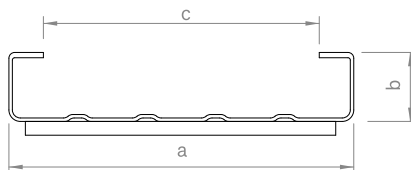
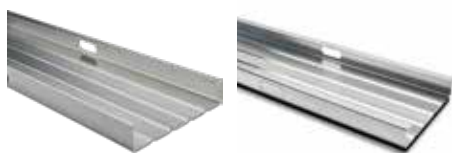

Base trough for flat roof elevations for click-fit of the base foots and module supports (flat roof system II) or for fixing the base profile (flat roof system I) and inserting the ballast. Constructed as a base trough without or with a pre-assembled separation layer.

Item no.	Designation	a in mm	b in mm	c in mm	Material
03-000711	Base trough 150-30 3.00m	150	30	120	Alu
03-000087	Base trough 150-30 6.00m	150	30	120	Alu
03-000988	Base trough 150-30 w/protection layer 3.00m	150	30	120	Alu/PE
03-000989	Base trough 150-30 w/protection layer 6.00m	150	30	120	Alu/PE

Base troughs cross drainage flat roof

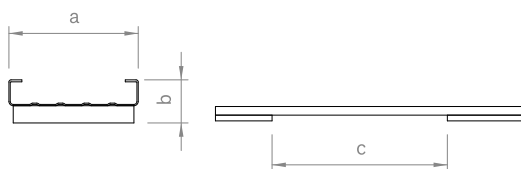

Base trough for flat roof elevations for click-fit of the base foots and module supports (flat roof system II) or for fixing the base profile (flat roof system I) and inserting the ballast. Pre-assembled with PE pads, grid 610 mm, as separation or drainage layer when placed transversely to the roof pitch.

Item no.	Designation	a in mm	b in mm	c in mm	Material
03-000920	Base trough 150-30 w/cross drainage 3.00m	150	50	610	Alu/PE
03-000879	Base trough 150-30 w/cross drainage 6.00m	150	50	610	Alu/PE

Coupling profile

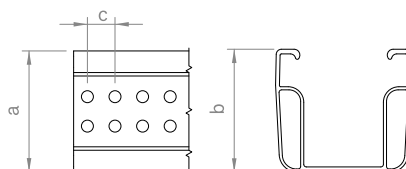

Coupling profile for reducing the ballast of adjacent module fields with expansion gaps in between on flat roof elevations through coupling of the bordering base troughs.

Item no.	Designation	a in mm	b in mm	c in mm	Material
03-000929	Coupling profile C47 385 mm	52	47	12	Alu

Gravel base trough

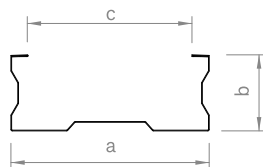

Base trough for flat roof elevations to fix the base profiles and for ballasting with existing gravel.

Item no.	Designation	a in mm	b in mm	c in mm	Material
03-00092	Base trough 230-90 6.00 m	230	90	190	Alu

Base profile elevation

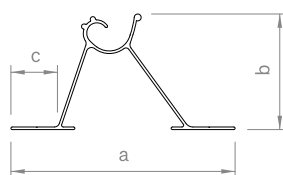

Module support rail for module elevation on flat roofs as well as for trapezoidal sheet, corrugated and sandwich roofs.

Item no.	Designation	a in mm	b in mm	c in mm	Material
03-000193	Base profile 6.12 m	130	67	27	Alu
03-000194	Base profile 5.06 m	130	67	27	Alu
03-000195	Base profile 3.37 m	130	67	27	Alu

Support brace east-west II

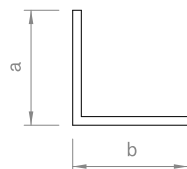

Support brace for load transfer, fixed on the flat roof module support sets east-west II.

Item no.	Designation	a in mm	b in mm	c in mm	Material
03-000314	Support brace 20 × 20 × 1.5 5.15 m	20	20		Alu
03-001247	Support brace 20 × 20 × 1.5 4.25 m	20	20		Alu
03-000722	Support brace 20 × 20 × 1.5 1.75 m	20	20		Alu

Rail connector insertion rail



Connector insertion rail for framed modules, l = 150 mm, available in blank or black anodised variations.

Item no.	Designation	a in mm	b in mm	c in mm	Material
03-000648	Rail connector set IR	65	18		Alu / A2SS
03-000499	Rail connector set IR black	65	18		Alu / A2SS

Rail connector insertion rail trapezoidal

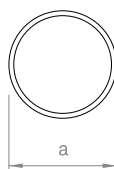

Connector insertion rail for framed modules, l = 100 mm, for direct mounting on trapezoidal sheet.

Item no.	Designation	a in mm	b in mm	c in mm	Material
03-000647	Rail connector IR 5x100 A2SS	5			A2SS

Rail connector insertion rail frameless modules

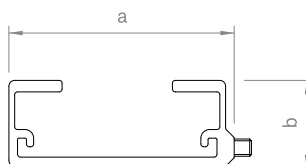

Connector insertion rail for frameless modules, l = 150 mm.

Item no.	Designation	a in mm	b in mm	c in mm	Material
03-000649	Rail connector set IR FL	78	31		Alu / A2SS

Rail connector insertion rail plus

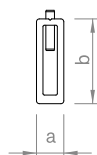
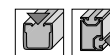

Connector insertion rail Plus for framed modules, l = 200 mm.

Item no.	Designation	a in mm	b in mm	c in mm	Material
03-000471	Rail connector set IR Plus	10	30		Alu



Rail connector snowguard insertion rail plus



Connector for snow stop IR 20 x 5, l = 200mm.

Item no.	Designation	a in mm	b in mm	c in mm	Material
03-000494	Rail connector set snowguard IR	8			Alu

Rail connector C-rail 38

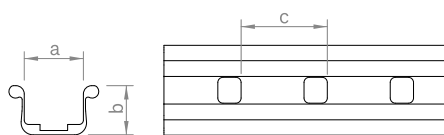

Connector C-rail 38, l = 325mm, with two round-head screws and locking nuts with 18 AF hexagon drive, available as expansion joint construction with four round-head screws.

Item no.	Designation	a in mm	b in mm	c in mm	Material
03-001105	Rail connector set C38	35	28.5	50	Alu/A2SS
03-001106	Expansion joint C38	35	28.5	50	Alu/A2SS

Rail connector C-rail profile chambers

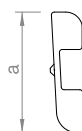

Connector C-rail 47, l = 200mm, screw connection with four self-drilling screws with 8 AF hexagon drive.

Item no.	Designation	a in mm	b in mm	c in mm	Material
03-000925	Rail connector set C47 S	30			Alu/A2SS

Rail connector C-rail 47

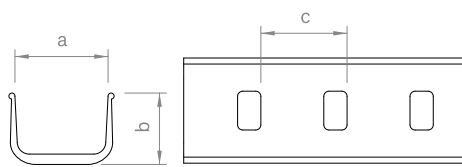

Connector C-rail 47, l = 325mm, with two round-head screws and locking nuts with 18 AF hexagon drive, available as expansion joint construction with four round-head screws.

Item no.	Designation	a in mm	b in mm	c in mm	Material
03-000001	Rail connector set C47	52	40	50	Alu/A2SS
03-000138	Expansion joint C47	52	40	50	Alu/A2SS

Rail connector C-rail 71

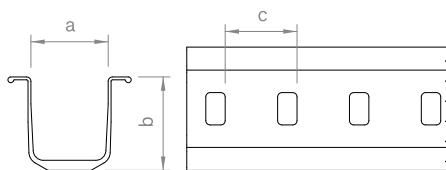

Connector C-rail 71, l = 490 mm, with four round-head screws, washers and locking nuts with 18 AF hexagon drive, available as expansion joint construction.

Item no.	Designation	a in mm	b in mm	c in mm	Material
03-000151	Rail connector C-rail 71	52	67	50	Alu / A2SS
03-000265	Rail connector C-rail 71	52	67	50	Alu / A2SS

Rail connector C-rail 95

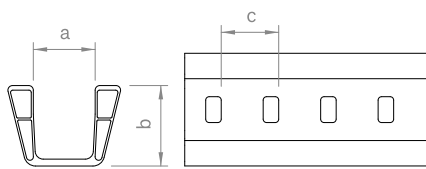

Connector C-rail 95, l = 500 mm, with four round-head screws, washers and locking nuts with 18 AF hexagon drive, available as expansion joint construction.

Item no.	Designation	a in mm	b in mm	c in mm	Material
03-000130	Rail connector set C95	52	70	50	Alu / A2SS
03-000173	Expansion joint C95	52	70	50	Alu / A2SS

Rail connector N-rail

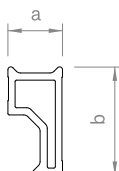

Connector N-rail, l = 200 mm or l = 150 mm, screw connection with two self-drilling screws with 8 AF hexagon drive.

Item no.	Designation	a in mm	b in mm	c in mm	Material
03-000500	Rail Connector set N Eco	19	38	200	Alu / A2SS
03-000524	Rail Connector set N Standard	27	41	150	Alu / A2SS

Rail connector N-rail

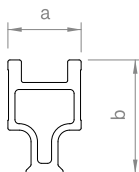

Connector N-rail, l = 150 mm or l = 400 mm, screw connection with two or four self-drilling screws with 8 AF hexagon drive.

Item no.	Designation	a in mm	b in mm	c in mm	Material
03-000523	Rail Connector set N Premium	36	56	150	Alu / A2SS
03-000501	Rail Connector set N L	45	85	400	Alu / A2SS

Rail connector elevation profile pair H45

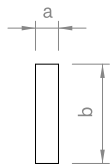

Connector elevation profile pair H45, l = 160 mm.

Item no.	Designation	a in mm	b in mm	c in mm	Material
03-000496	Rail Connector set elevation profile pair H45	5	22		Alu

Rail connector elevation profile pair H136

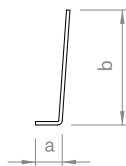

Connector elevation profile pair H136, l = 150 mm, screw connection with four thin sheet screws with 8 AF hexagon drive.

Item no.	Designation	a in mm	b in mm	c in mm	Material
03-000525	Rail Connector set elevation profile pair H136	12	50		Alu/A2SS

Base trough connector 150-30 I

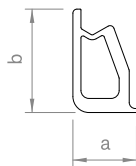

Connector Base trough 150-30, l = 380 mm.

Item no.	Designation	a in mm	b in mm	c in mm	Material
03-000370	Base trough connector set 150-30 I	16	26		Alu

Base trough expansion joint

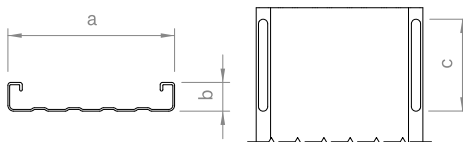

Base trough expansion joint 150-30, l = 380 mm, single-sided with slots.

Item no.	Designation	a in mm	b in mm	c in mm	Material
03-000128	Base trough expansion joint 150-30	150	25	80	Alu

Angled base trough connector 150-30

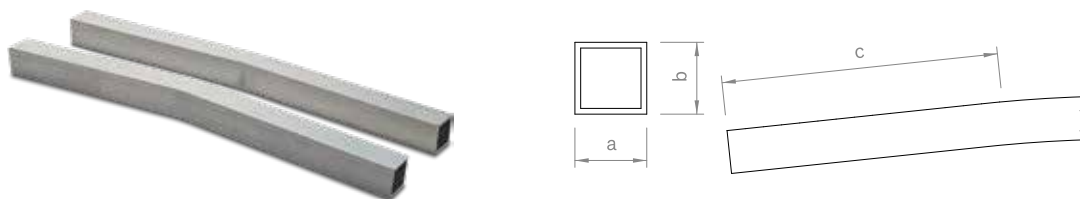

Connector base trough, $l = 380$ mm, for ridge and throat formation $2^\circ - 5^\circ$.

Item no.	Designation	a in mm	b in mm	c in mm	Material
03-000161	Angled base trough connector 150-30 3°	25	25	180	Alu

Base profile connector

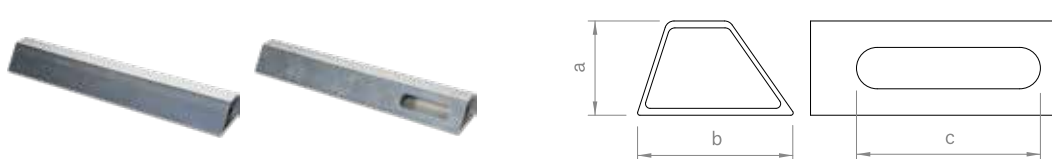

Connector base profile, $l = 380$ mm, available as expansion joint construction single-sided with slots.

Item no.	Designation	a in mm	b in mm	c in mm	Material
03-000021	Base profile connector	41	68		Alu
03-000129	Base profile expansion joint	41	68	80	Alu

Angled base profile connector (rise)

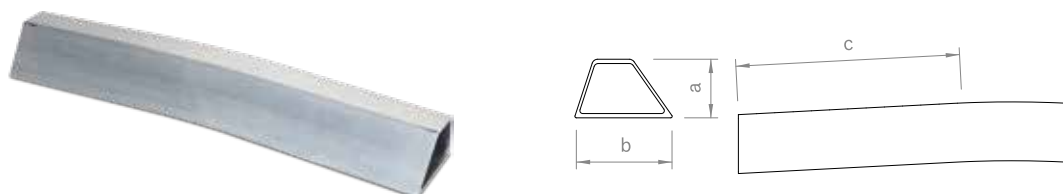

Connector base profile, $l = 380$ mm, for ridge formation $2^\circ - 5^\circ$.

Item no.	Designation	a in mm	b in mm	c in mm	Material
03-000162	Angled base profile connector 3° (rise)	41	68	150	Alu

Angled base profile connector (dip)

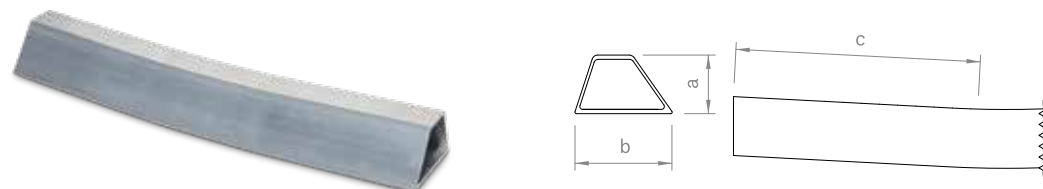

Connector base profile, $l = 380$ mm, for throat formation $2^\circ - 5^\circ$.

Item no.	Designation	a in mm	b in mm	c in mm	Material
03-000163	Angled base profile connector 3° (dip)	41	68	150	Alu

Connection insertion rail on C-rail

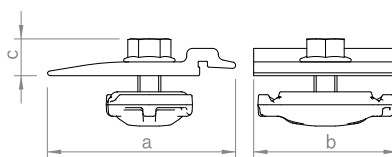

Connector for fixing insertion rails on C-rails and mounting triangles, locking nut with 13 AF hexagon drive, completely pre-assembled.

Item no.	Designation	a in mm	b in mm	c in mm	Material
03-000321	Cross rail connector set C IR M8	66	50	13	Alu / A2SS

Connection insertion rail on N-rail

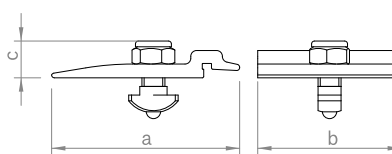

Connector for fixing insertion rails on N-rails, slot bolt M8 and locking nut with 13 AF hexagon drive, completely pre-assembled.

Item no.	Designation	a in mm	b in mm	c in mm	Material
03-000409	Cross rail connector set N IR M8	66	50	13	Alu / A2SS

Connection C-rail on C-rail

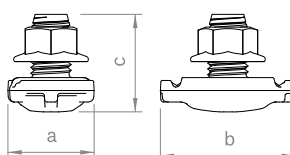

Connector for fixing C-rails to create a cross rail configuration, locking nut M14 with 18 AF hexagon drive.

Item no.	Designation	a in mm	b in mm	c in mm	Material
03-000226	Cross rail connector set C M14	30	46	34	Alu / A2SS

Connection N-rail on N-rail

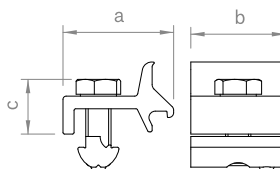

Connector for fixing N-rails to create a cross rail configuration, slot bolt M8 13 AF hexagon drive and slot nut, I = 30 mm or I = 65 mm.

Item no.	Designation	a in mm	b in mm	c in mm	Material
03-000599	Cross rail connector set N 30 mm M8	35	30	22	Alu / A2SS
03-000904	Cross rail connector set N 65 mm M8	35	65	22	Alu / A2SS

Connection N-rail on C-rail

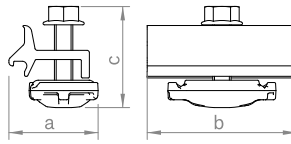

Connector fixing N-rails on C-rails to create a cross rail configuration, locking nut with 13 AF hexagon drive, completely pre-assembled.

Item no.	Designation	a in mm	b in mm	c in mm	Material
03-000919	Cross rail connector set NC M8	38	65	44	Alu / A2SS

Edge stops insertion rail

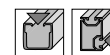

Edge stop for insertion rails, fixing with tapping screw Torx drive 30.

Item no.	Designation	a in mm	b in mm	c in mm	Material
03-000691	Edge stop set IR	49	49		Alu / A2SS
03-000693	Edge stop set IR black	49	49		Alu / A2SS

Edge stop insertion rail frameless modules



Edge stop for insertion rail FL with EPDM seal, fixing with self-drilling screw 8 AF hexagon drive.

Item no.	Designation	a in mm	b in mm	c in mm	Material
03-000692	Edge stop set IR FL	70	50	50	Alu / A2SS

Edge stop insertion rail plus



Edge stop for insertion rails Plus, fixing with self-drilling screw Torx drive 30.

Item no.	Designation	a in mm	b in mm	c in mm	Material
03-000732	Edge stop set IR Plus	75	75		Alu / A2SS

Module protections insertion rail

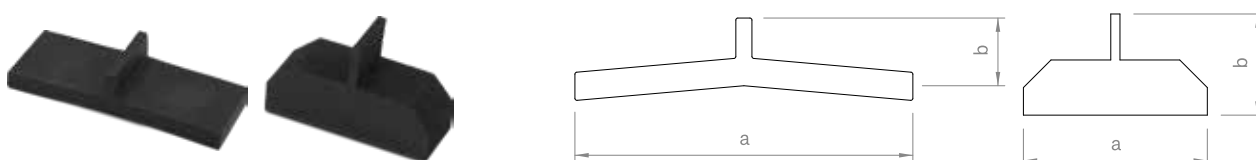
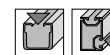

EPDM-T protection for fixing modules in insertion rails with minimal module slope, for framed or unframed modules.

Item no.	Designation	a in mm	b in mm	c in mm	Material
03-000631	EPDM-T protection IR	84	17		EPDM
03-000630	EPDM-T protection IR FL	40	22		EPDM

Module slip guards portrait orientation



Slip guard for fixing modules with and without mounting holes for mounting modules in portrait.

Item no.	Designation	a in mm	b in mm	c in mm	Material
03-000006	Module slip guard set M6	25			A2SS
03-000007	Module slip guard set M8	25			A2SS
03-000372	Module slip guard set box frame	20			A2SS

Slip guards and end caps C-rail



Slip guard for fixing modules mounted in landscape or as an end cap for the C-rail, available in blank or black.

Item no.	Designation	a in mm	b in mm	c in mm	Material
03-000259	Slip Guard/ End Cap Set C47	53	80	80	Alu/ A2SS
03-000260	Slip guard/ End Cap Set C47 black	53	80	80	Alu/ A2SS
03-000261	Slip Guard/ End cap C71	53	100	80	Alu/ A2SS
03-000262	Slip guard/ End Cap Set C71 black	53	100	80	Alu/ A2SS
03-000263	Slip Guard/ End Cap Set C95	53	130	80	Alu/ A2SS
03-000264	Slip Guard/ End cap Set C95 black	53	130	80	Alu/ A2SS

End caps C-rail

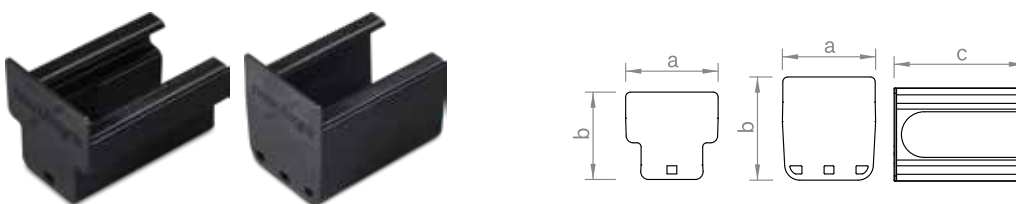

End cap in black for C-rail 38 and C-rail 47, UV and weather resistant.

Item no.	Designation	a in mm	b in mm	c in mm	Material
03-001110	End cap C-rail C38 black	57	54	80	PP
03-001111	End cap C-rail C47 black	57	63	80	PP

End caps N-rail

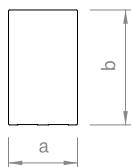

End cap in black for N-rails, UV and weather resistant.

Item no.	Designation	a in mm	b in mm	c in mm	Material
03-000527	End cap N-rail Eco	22	50		PA 6.6
03-000529	End cap N-rail Standard	30	50		PA 6.6
03-000528	End cap N-rail Premium	40	60		PA 6.6

Slip guard short profile trapezoidal

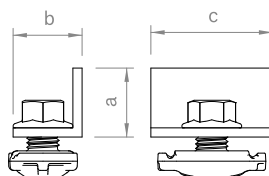

Slip guard with 18 AF locking nut for securing the modules mounted in landscape on short rails.

Item no.	Designation	a in mm	b in mm	c in mm	Material
03-000233	Slip guard set for short profile M14	30	30	53	Alu/A2SS

Edge stop elevation profile pair

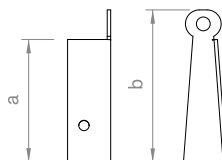

Edge stop for elevation profile pair H136, fixing with 8 AF hexagon drive thin sheet screw.

Item no.	Designation	a in mm	b in mm	c in mm	Material
03-000593	Edge stop set elevation profile pair H136	71	88		Alu/A2SS

Top cover C-rail

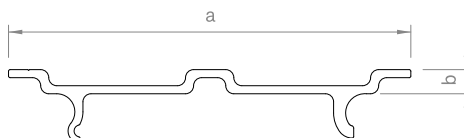

Cover to clip on to the C-rail if using as cable channel.

Item no.	Designation	a in mm	b in mm	c in mm	Material
03-000134	Top cover C-rail 2.00 m	50	3		Alu

Adapter top cover C-Rail

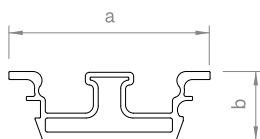

Adapter for the optional fixing of the C-rail top cover if using as cable channel.

Item no.	Designation	a in mm	b in mm	c in mm	Material
03-000319	Adapter top cover C-Rail	50	17		Alu

Top cover base trough

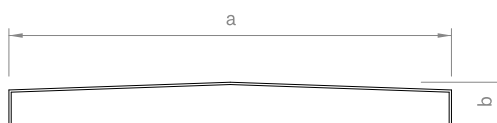

Cover for the base trough if using as cable channel.

Item no.	Designation	a in mm	b in mm	c in mm	Material
03-000133	Top cover base trough 150-30 3.00m	154	15		Alu

Middle clamps C-rail

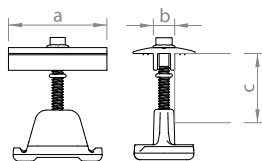

Middle clamp for fixing the modules on the C-rail. Clamping screw with 8 AF hexagon drive. For frame heights of 28–33 mm, 34–42 mm or 43–52 mm, available in blank or black anodised variations.

Item no.	Designation	a in mm	b in mm	c in mm	Material
03-000302	Middle clamp 28-33 Set C black	52	11.4	28–33	Alu/A2SS
03-000301	Middle clamp 28-33 Set C	52	11.4	28–33	Alu/A2SS
03-000276	Middle clamp 34-42 Set C black	52	11.4	34–42	Alu/A2SS
03-000275	Middle clamp 34-42 Set C	52	11.4	34–42	Alu/A2SS
03-000286	Middle clamp 43-52 Set C black	52	11.4	43–52	Alu/A2SS
03-000285	Middle clamp 43-52 Set C	52	11.4	43–52	Alu/A2SS

End clamps C-rail

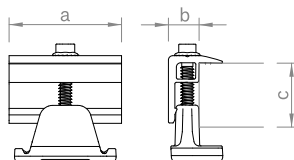

End clamp for fixing the modules on the C-rail. Clamping screw with 8 AF hexagon drive. For frame heights of 28–33 mm, 34–42 mm or 43–52 mm, available in blank or black anodised variations.

Item no.	Designation	a in mm	b in mm	c in mm	Material
03-000299	End clamp 28-33 Set C black	52	14	28–33	Alu/V2A
03-000298	End clamp 28-33 Set C	52	14	28–33	Alu/V2A
03-000284	End clamp 34-42 Set C black	52	14	34–42	Alu/V2A
03-000277	End clamp 34-42 Set C	52	14	34–42	Alu/V2A
03-000288	End clamp 43-52 Set C black	52	14	43–52	Alu/V2A
03-000287	End clamp 43-52 Set C	52	14	43–52	Alu/V2A

Middle clamps N-rail

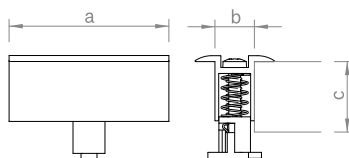

Middle clamp with spring mechanism for fixing the modules on the N-rail. Clamping screw with AW 30 drive. For frame heights of 31–40 mm or 41–50 mm, available in blank or black anodised variations.

Item no.	Designation	a in mm	b in mm	c in mm	Material
03-000569	Middle clamp 31-40 Set N black	80	20	31–40	Alu/V2A
03-000570	Middle clamp 31-40 Set N	80	20	31–40	Alu/V2A
03-000571	Middle clamp 41-50 Set N black	80	20	41–50	Alu/V2A
03-000572	Middle clamp 41-50 Set N	80	20	41–50	Alu/V2A

End clamps N-rail

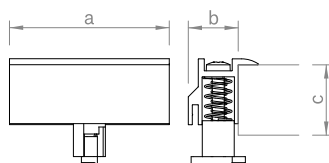

End clamp with spring mechanism for fixing the modules on the N-rail. Clamping screw with AW 30 drive. For frame heights of 31 – 40 mm or 41 – 50 mm, available in blank or black anodised variations.

Item no.	Designation	a in mm	b in mm	c in mm	Material
03-000964	End clamp 31-40 Set N black	80	25	31 – 40	Alu / A2SS
03-000551	End clamp 31-40 Set N	80	25	31 – 40	Alu / A2SS
03-000552	End clamp 41-50 Set N black	80	25	41 – 50	Alu / A2SS
03-000553	End clamp 41-50 Set N	80	25	41 – 50	Alu / A2SS

Spacers end clamps N-rail

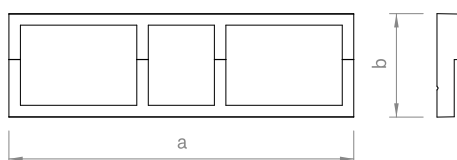

Spacer for the end clamps of the N-rail, height is dependent on the frame height.

Item no.	Designation	a in mm	b in mm	c in mm	Material
03-000614	Spacer end clamp N 31-32 mm	60	11		PA 6.6
03-000615	Spacer end clamp N 33-35 mm	60	15		PA 6.6
03-000616	Spacer end clamp N 36-38 mm	60	18		PA 6.6
03-000617	Spacer end clamp N 39-40 mm	60	20		Alu
03-000618	Spacer end clamp N 41-42 mm	60	22		PA 6.6
03-000619	Spacer end clamp N 43-46 mm	60	25		PA 6.6
03-000620	Spacer end clamp N 47-48 mm	60	29		PA 6.6
03-000621	Spacer end clamp N 49-50 mm	60	30		Alu

Middle clamp frameless 6.8 - 8.0 C-rail

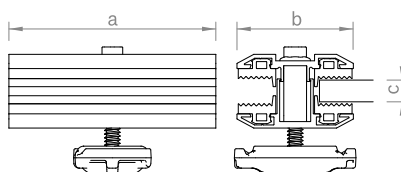

Middle clamp for fixing frameless modules on the C-rail, permissible glass thickness 6.8–8.0 mm, completely pre-assembled. Clamping screw with AF 8 hexagon drive.

Item no.	Designation	a in mm	b in mm	c in mm	Material
03-000312	Middle clamp FL 6.8-8.0 mm Set C	80	45	6.8 – 8.0	Alu / EPDM

End clamp frameless 6.8–8.0 C-rail

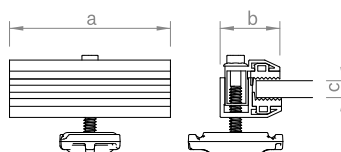

End clamp for fixing frameless modules on the C-rail, permissible glass thickness 6.8–8.0mm, completely pre-assembled. Clamping screw with AF 8 hexagon drive.

Item no.	Designation	a in mm	b in mm	c in mm	Material
03-000317	End clamp FL 6.8–8.0mm Set C	80	30.5	6.8–8.0	Alu/EPDM

Middle clamp frameless 6.8–8.0 N-rail

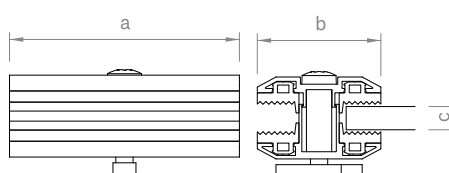

Middle clamp for fixing frameless modules on the N-rail, permissible glass thickness 6.8–8.0mm, completely pre-assembled. Clamping screw with AW 30 drive.

Item no.	Designation	a in mm	b in mm	c in mm	Material
03-000547	Middle clamp FL 6.8–8.0mm Set N	80	45	6.8–8.0	Alu/EPDM

End clamp frameless 6.8–8.0 N-rail

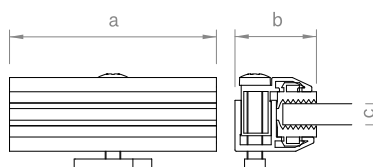

End clamp for fixing frameless modules on the N-rail, permissible glass thickness 6.8–8.0mm, completely pre-assembled. Clamping screw with AW 30 drive.

Item no.	Designation	a in mm	b in mm	c in mm	Material
03-000532	End clamp FL 6.8–8.0mm Set N	80	30.5	6.8–8.0	Alu/EPDM

Middle clamp frameless 6.8–6.9 N-rail

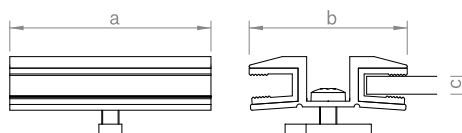

Middle clamp for fixing frameless modules on the N-rail, permissible glass thickness 6.8–6.9mm, completely pre-assembled. Clamping screw with AW 30 drive.

Item no.	Designation	a in mm	b in mm	c in mm	Material
03-000533	Middle clamp FL 6.8–6.9mm Set N	70	54	6.8–6.9	Alu/EPDM

End clamp frameless 6.8-6.9 N-rail

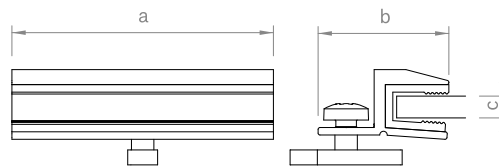

End clamp for fixing frameless modules on the N-rail, permissible glass thickness 6.8-6.9mm, completely pre-assembled. Clamping screw with AW 30 drive.

Item no.	Designation	a in mm	b in mm	c in mm	Material
03-000531	End clamp FL 6.8-6.9mm Set N	70	34.5	6.8-6.9	Alu/EPDM

Base foot

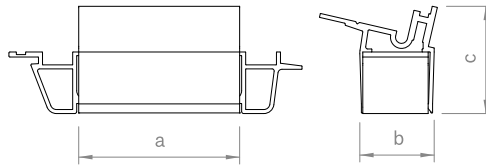

Front module support of the flat roof system generation II, to clip into the base trough.

Item no.	Designation	a in mm	b in mm	c in mm	Material
03-000343	Base foot set 13° 150-30	80	37	53	Alu

Module support closed II

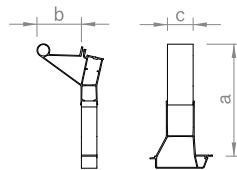

Rear module support of the closed flat roof system II, to clip into the base trough and to fix the wind deflector 13° on it.

Item no.	Designation	a in mm	b in mm	c in mm	Material
03-001243	Module support set 13° 150-30	260	104	60	Alu

Module support east-west II

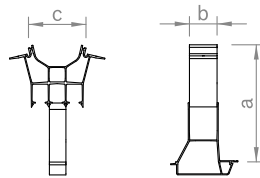

Rear module support for flat roof system east-west II, to clip into the base trough and to connect the support brace, constructed as a one-hip or two-hip support.

Item no.	Designation	a in mm	b in mm	c in mm	Material
03-000442	Module support set 13° 150-30 e/w single	255	60	125	Alu
03-000443	Module support set 13° 150-30 e/w double	255	60	125	Alu

Flat roof mid clamp (short side)

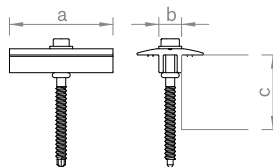

Middle clamp for flat roof system generation II, for fixing modules on the short side of the frame. Clamping screw with 8 AF hexagon drive, for frame heights of 28–42 mm or 43–52 mm, completely pre-assembled.

Item no.	Designation	a in mm	b in mm	c in mm	Material
03-000324	Flat Roof Mid Clamp 28-42	52	11.4	28 - 42	Alu / A2SS
03-000323	Flat Roof Mid Clamp 43-52	52	11.4	43 - 52	Alu / A2SS

Flat roof end clamp (short side)

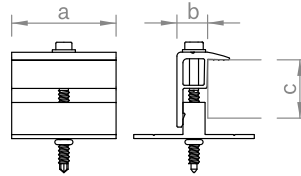

End clamp with T-adapter for flat roof system generation II, for fixing modules on the short side of the frame. Clamping screw with 8 AF hexagon drive, for frame heights of 28 – 33 mm, 34 – 42 mm or 43 – 52 mm, completely pre-assembled.

Item no.	Designation	a in mm	b in mm	c in mm	Material
03-000310	Flat Roof End Clamp (Short side) 28-33	52	14	28 – 33	Alu / A2SS
03-000309	Flat Roof End Clamp (Short side) 34-42	52	14	34 – 42	Alu / A2SS
03-000311	Flat Roof End Clamp (Short side) 43-52	52	14	43 – 52	Alu / A2SS

Flat roof end clamp (long side)

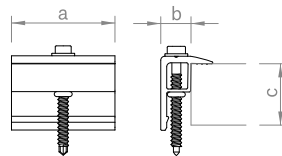

End clamp for flat roof system generation II, for securing modules on the long side of the frame. Clamping screw with 8 AF hexagon drive, for frame heights of 28 – 33 mm, 34 – 42 mm or 43 – 52 mm, completely pre-assembled.

Item no.	Designation	a in mm	b in mm	c in mm	Material
03-000326	Flat Roof End Clamp 28-33	52	14	28 – 33	Alu / A2SS
03-000396	Flat Roof End Clamp 34-42	52	14	34 – 42	Alu / A2SS
03-000397	Flat Roof End Clamp 43-52	52	14	43 – 52	Alu / A2SS

Wind deflector closed II

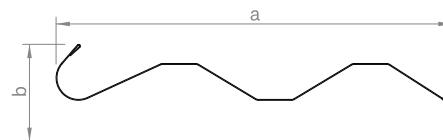

Wind deflector for flat roof system closed II for wind deflection and ballast reduction.

Item no.	Designation	a in mm	b in mm	c in mm	Material
03-000331	Wind Deflector 13° 1.85 m	270	70		Alu
03-001227	Wind Deflector 13° 2.25 m	270	70		Alu

Wind deflector east-west II

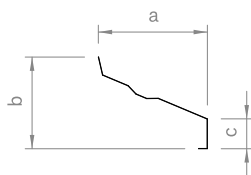

Wind deflector for flat roof system east-west II for mounting areas with missing module due to obstacles.

Item no.	Designation	a in mm	b in mm	c in mm	Material
03-000786	Wind Deflector 13° 1.85 m east-west	241	175	65	Alu

Ballast troughs base trough

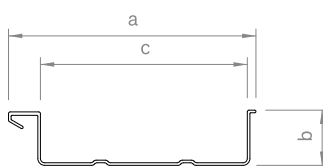

Ballast trough to clip into the base trough and secure placement of large format ballast. Constructed as a ballast trough without or with a pre-assembled separation layer.

Item no.	Designation	a in mm	b in mm	c in mm	Material
03-000131	Ballast trough 120-30 530 mm	144	32	120	Alu
03-000977	Ballast trough 530mm protection layer 6mm	144	32	120	Alu/PE
03-000910	Ballast trough QE 530mm	144	32	120	Alu/PE

Module bracket front mounting hole

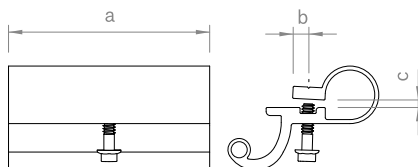

Front module support for flat roof system generation I or elevation on pitched roof, to connect to the module frame holes, completely pre-assembled.

Item no.	Designation	a in mm	b in mm	c in mm	Material
03-000078	Module bracket set front	100	8	4	Alu/A2SS

Module bracket set direct box frame

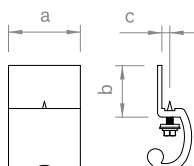

Front module support for flat roof system generation I or elevation on pitched roof, to directly connect to the module frame without frame holes, completely pre-assembled.

Item no.	Designation	a in mm	b in mm	c in mm	Material
03-000239	Module bracket set front direct (box fr.)	50	36	5.5	Alu/A2SS

Module bracket back mounting hole

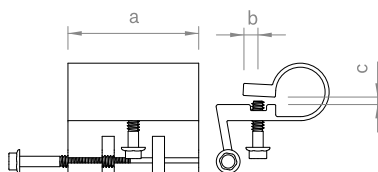

Rear module support for flat roof system open or elevation on pitched roof, to connect to the module frame holes, completely pre-assembled.

Item no.	Designation	a in mm	b in mm	c in mm	Material
03-000061	Module bracket set back	65	8	4	Alu/A2SS

Module support 13° - 40° open

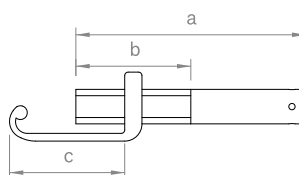

Rear module support for flat roof system open or elevation on pitched roof, in different lengths to elevate modules, continuous adjustable elevation angle, completely pre-assembled.

Item no.	Designation	a in mm	b in mm	c in mm	Material
03-000070	Module support set 200mm	200	100	100	Alu
03-000071	Module support set 280mm	280	100	100	Alu
03-000083	Module support set 360mm	360	100	100	Alu
03-000022	Module support set 440mm	440	100	100	Alu
03-000072	Module support set 520mm	520	100	100	Alu

Module support closed I

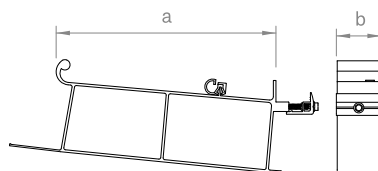

Module support for flat roof system closed I, for fixed elevation of modules at an angle of 13° and to connect the wind deflector 13° on it, securing the modules on the long side of the frame, for frame heights 28–33 mm, 34–42 mm or 43–52 mm, completely pre-assembled.

Item no.	Designation	a in mm	b in mm	c in mm	Material
03-000330	Module support set 13° 28–33 mm	255	50		Alu/A2SS
03-000030	Module support set 13° 34–42 mm	255	50		Alu/A2SS
03-000031	Module support set 13° 43–52 mm	255	50		Alu/A2SS

Module support east-west I

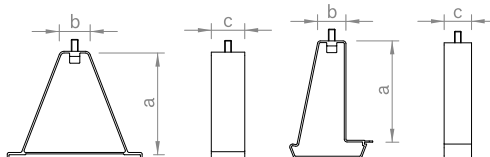

Module support for flat roof system east-west I for placement and fixing of the C-rail 71, available for the base trough 150-30 or the base trough 230-90.

Item no.	Designation	a in mm	b in mm	c in mm	Material
03-000181	Module support set east-west 230	180	50	60	Alu/A2SS
03-000180	Module support set east-west 150	180	50	50	Alu/A2SS

Module bracket back east-west I

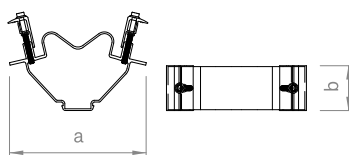

Module support for flat roof system east-west I, to clip into the C-rail, fixing the modules on the long side of the frame, for frame heights 28–33 mm, 34–42 mm or 43–52 mm.

Item no.	Designation	a in mm	b in mm	c in mm	Material
03-000322	Module bracket set back east-west 28–33 mm	159	52		Alu/A2SS
03-000098	Module bracket set back east-west 34–42 mm	159	52		Alu/A2SS
03-000095	Module bracket set back east-west 43–52 mm	159	52		Alu/A2SS

Wind deflector closed I

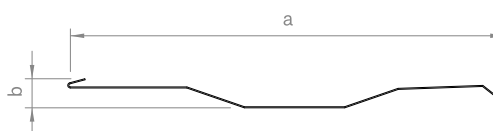

Wind deflector for flat roof system closed I for wind deflection and ballast reduction.

Item no.	Designation	a in mm	b in mm	c in mm	Material
03-000013	Wind deflector 13° 1.72 m	330	23		Alu

Mounting triangles

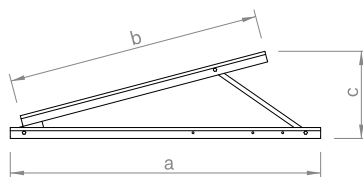

Triangles in different sizes with four variable elevation angles, mountable on flat and pitched roofs, module fixation possible with module clamps or insertion rails.

Item no.	Designation	a in mm	b in mm	c in mm	Material
03-000931	Mounting triangle 15/20/25/30° 1100	1350	1100	285 – 550	Alu/A2SS
03-000932	Mounting triangle 15/20/25/30° 1300	1600	1300	336 – 650	Alu/A2SS
03-000933	Mounting triangle 15/20/25/30° 1500	1900	1500	388 – 750	Alu/A2SS

Cross bracing mounting triangles

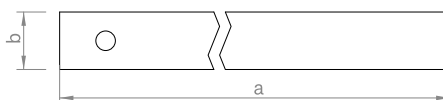

For cross bracing of mounting triangles, consisting of flat aluminium material 25x4, l = 1800mm and two 8 AF hexagon drive self-drilling screws.

Item no.	Designation	a in mm	b in mm	c in mm	Material
03-000685	Cross bracing set elevation triangle rack	1800	25		Alu/A2SS

Facade

Sockets insertion rail

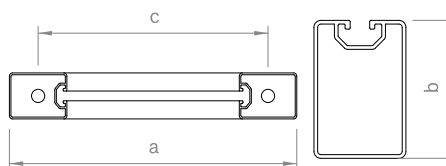

Socket for fixing insertion rails on building facades, drill holes $d = 11.5\text{mm}$, delivered with two facade dowels and the matching screws.

Item no.	Designation	a in mm	b in mm	c in mm	Material
03-000580	Socket set 250mm 11.5	250	60	200	Alu/A2SS
03-000581	Socket set 250mm 11.5 black	250	60	200	Alu/A2SS

Adapter plates module protection and perforated sheet fixing

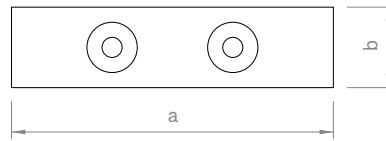

Adapter plate for securing the modules against slipping and for fixing perforated sheets. Prefabricated with two 5 mm drill holes for attachment on the socket as well as two countersunk washers and four countersunk head self-drilling screws with Torx drive 25.

Item no.	Designation	a in mm	b in mm	c in mm	Material
03-000384	Adapter plate set 80 × 20 × 8 mm	80	20		Alu / A2SS
03-000404	Adapter plate set 80 × 20 × 8 mm black	80	20		Alu / A2SS

Adapter plates edge stop and perforated sheet fixing

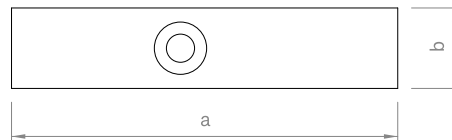

Adapter plate for lateral fixing of perforated sheets and as an edge stop for the modules. Prefabricated with a 7 mm drill hole for a countersunk head sheet screw with Torx drive 30 as well as two countersunk self-drilling screws with Torx drive 25.

Item no.	Designation	a in mm	b in mm	c in mm	Material
03-000385	Adapter plate set 96 × 20 × 3 mm	96	20		Alu / A2SS

Perforated sheets

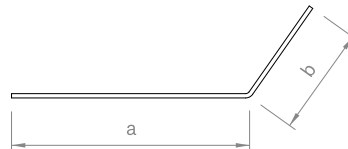
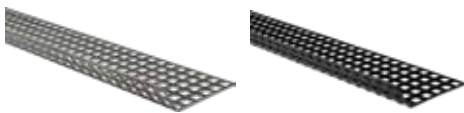

Perforated sheet to close the gap between the facade and module, enables rear ventilation and quick access to the rear of the modules, available in blank or black.

Item no.	Designation	a in mm	b in mm	c in mm	Material
03-000548	Perforated sheet 1500 × 120 mm 125°	83	38		St. galv.
03-000549	Perforated sheet 1500 × 120 mm 125° black	83	38		St. galv.

Connector perforated sheet



Connector for blank and black anodised perforated sheets, prefabricated with two drill holes, set with two countersunk washers and countersunk head self-drilling screws with Torx drive 25.

Item no.	Designation	a in mm	b in mm	c in mm	Material
03-000497	Connector set perforated sheet	65	20		Alu / A2SS

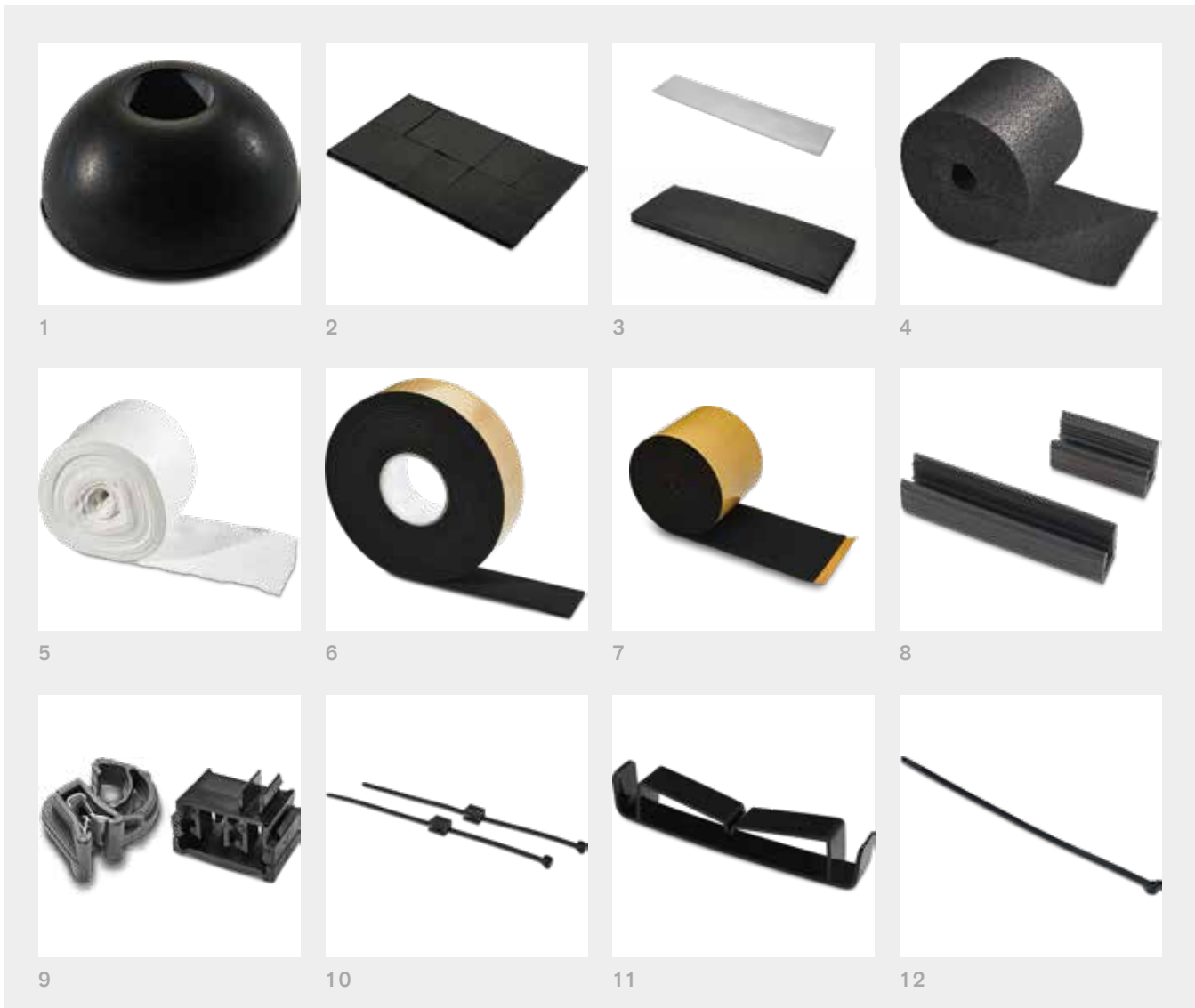

Item no.	Designation	Image number
03-000184	EPDM round seal d = 25 mm	1
03-000082	EPDM sealant strip for C-rail 50x35 mm	2
03-000407	Aluminium edge protector self-adhesive	3
03-000831	PE-Pad 140x390x20 mm	3
03-000105	Protective roof mat 10,000x250x6 mm	4
03-000113	Synthetic fibre strips 50,000x320	5
03-000627	EPDM tape 10,000x54x3 mm IR	6
03-000633	EPDM sealant strip 70x28x2 mm IR	7
03-000628	EPDM edge protection 7 mm laminate, L 40	8
03-000629	EPDM edge protection 7 mm laminate, L 80	8
03-000099	Cable clip d = 10 mm	9
03-000510	Cable collector N-rail PA 4 cables	9
03-000508	Cable-tie clip for profile flange 1-3 mm	10
03-000509	Cable-tie clip for profile flange 3-6 mm	10
03-000175	Base trough cable bracket	11
03-000504	Cable tie black, 140 mm	12
03-000505	Cable tie black, 200 mm	12
03-000506	Cable tie black, 280 mm	12
03-000507	Cable tie black, 360 mm	12

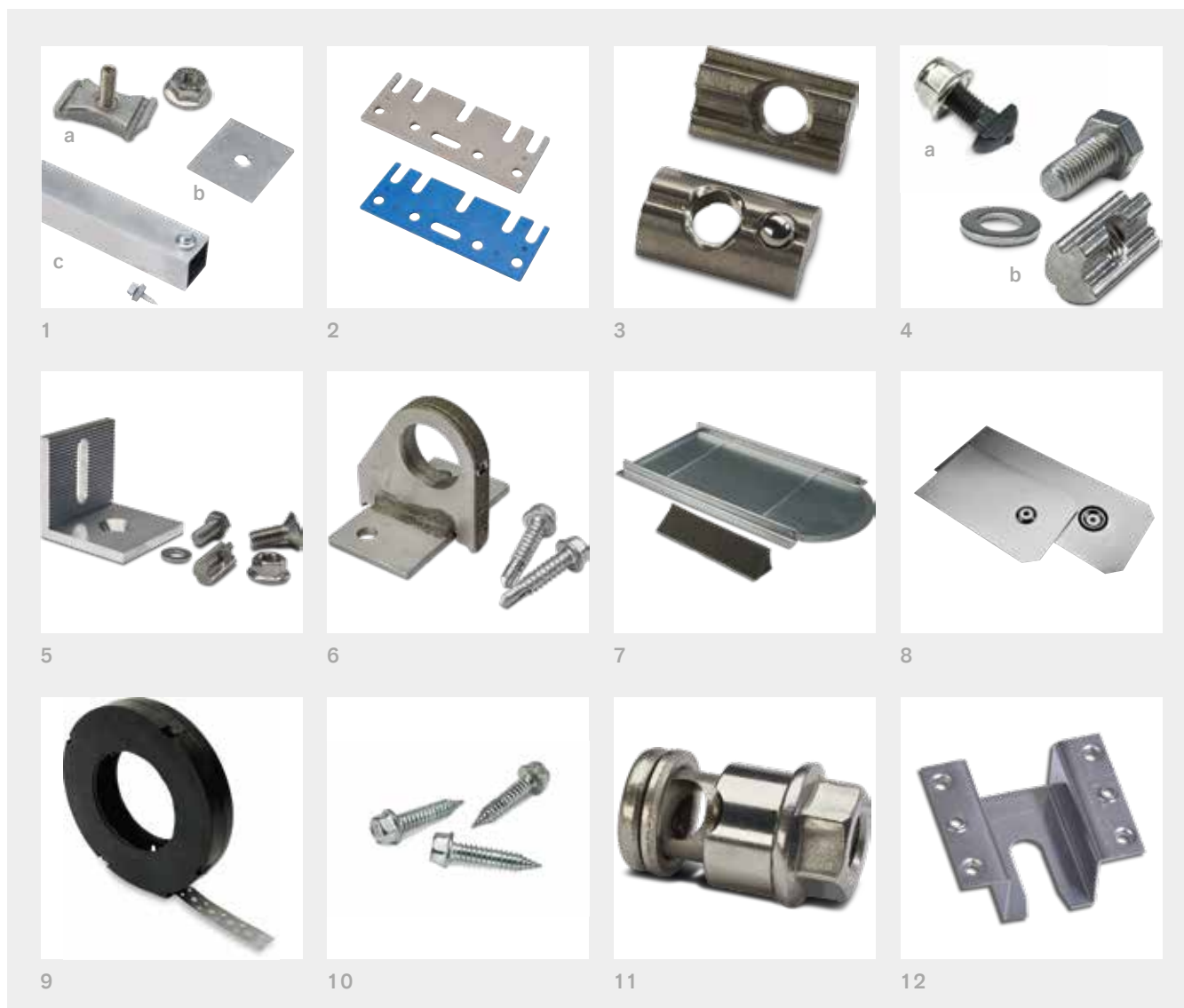

Item no.	Designation	Image number
03-000329	Mounting Set C-Rail M8	1a
03-000373	Plate 50x50x3 D8.5 Alu	1b
03-000337	Mounting-Set Optimizer FR	1c
03-000979	Shim for roof hook PP blue, 2mm	2
03-000980	Shim for roof hook PP grey, 5mm	2
03-000589	Slot nut A2SS with spring ball M8 30mm	3
03-000600	Slot nut Alu with spring ball M8 22mm	3
03-000682	Slot bolt M8 with serrated locking nut	4a
03-000683	L adapter set N-rail to C-shape roof hook	4b
03-000684	Slot nut set with screw M8x18 A2SS	4b
03-000530	Slot nut set with screw M8x16 A2SS	5
03-000476	Mounting set snowguard IR	6
03-000412	Metal sheet zinc-plated, for plain tile	7
03-000535	Metal shingle 280x230 mm, with sealing	8
03-000536	Metal shingle 390x230 mm, with sealing	8
03-000537	Metal shingle 580x230 mm, with sealing	8
03-000924	Perforated Alu-tape 10,000x20x1 mm	9
03-000778	Flat roof mounting screw cl 5.5	10
03-000012	Grounding connector set AF 18	11
03-001185	Contact latch module clamp	12

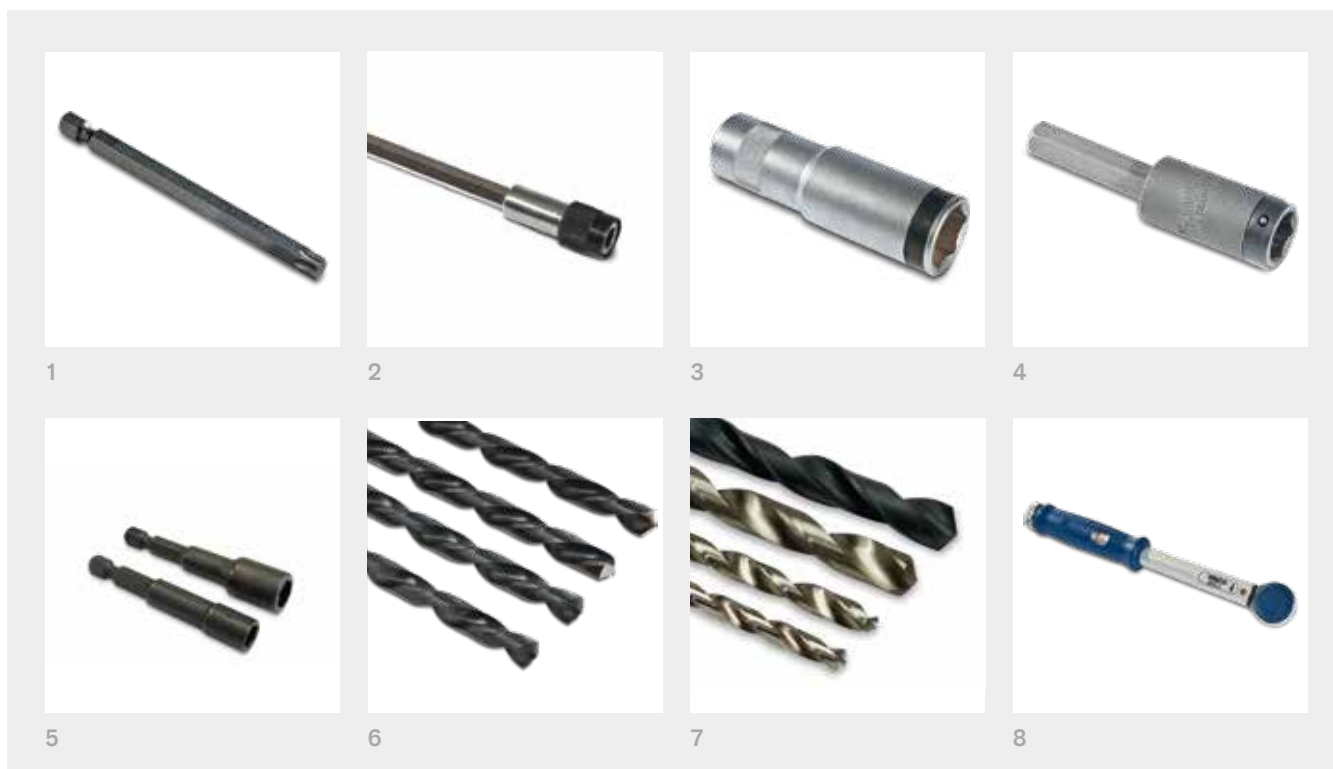

Item no.	Designation	Image number
03-000315	Torx drive TX-25 length = 70 mm	1
03-000104	Torx drive TX-40 length = 70 mm	1
03-000316	Torx drive TX-30 length = 70 mm	1
03-000038	Torx extension 250 mm	2
03-000011	Special long nut socket 18 mm	3
03-000100	Special nut socket 8 mm	4
03-000966	Hexagon drive for stock screw M10	5
03-000930	Hexagon drive for stock screw M12	5
03-000114	Drill bit 6.8 mm length 230 mm	6
03-000115	Drill bit 7.0 mm length 230 mm	6
03-000116	Drill bit 7.2 mm length 230 mm	6
03-000117	Drill bit 7.4 mm length 230 mm	6
03-000245	Drill bit 7.5 mm length 225 mm	7
03-000108	Drill bit 9.0 mm length 230 mm	7
03-000246	Drill bit 14 mm HSS short	7
03-000107	Drill bit 16 mm HSS short	7
03-000036	Torque wrench 1/4", 4-20 Nm	8

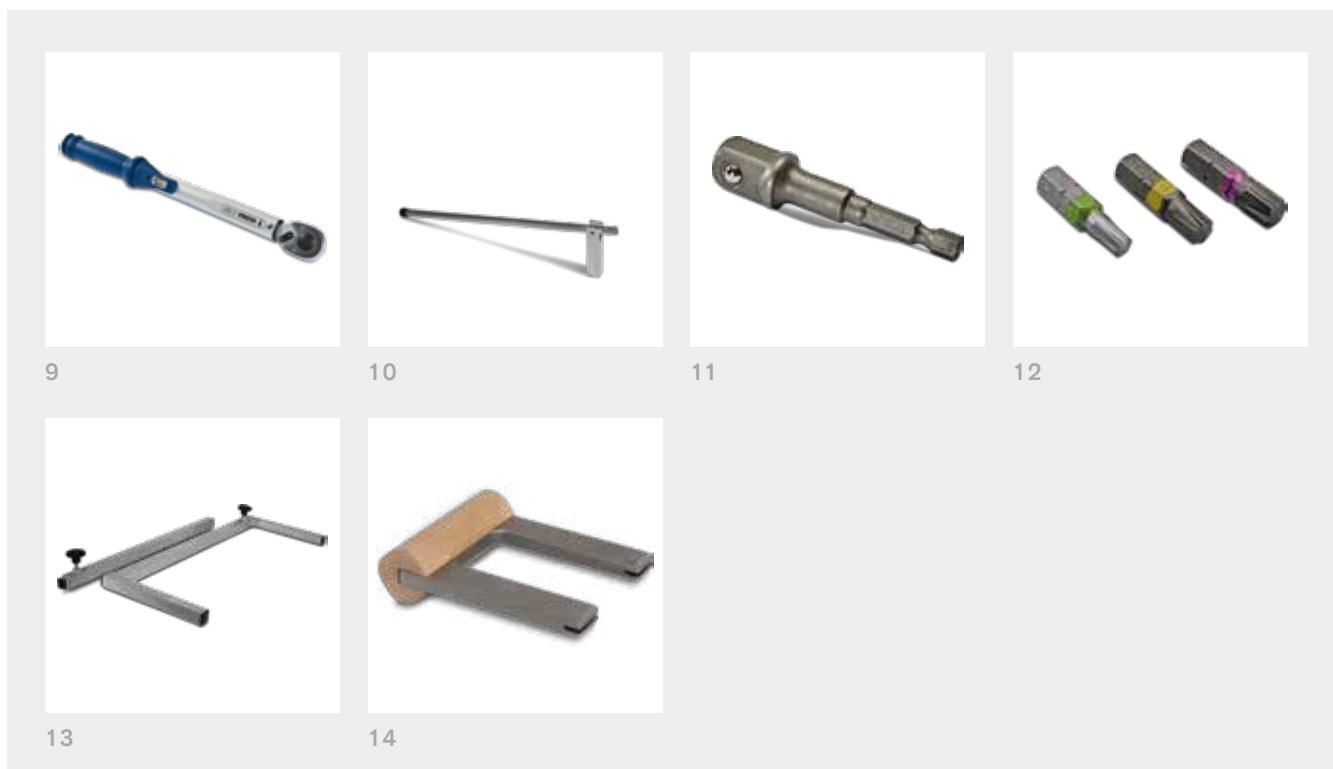

Item no.	Designation	Image number
03-00037	Torque wrench 1/2", 20-100 Nm	9
03-000362	Mounting and removal tool 150-30	10
03-000602	Adapter 1/4" hexagonal to 1/2" square	11
03-000604	Bit for triple-square screws, size AW25	12
03-000603	Bit for triple-square screws, size AW30	12
03-000605	Bit for triple-square screws, size AW40	12
03-000576	Assembling jig 800 - 1200 mm, C-shaped	13
03-000574	Assembling jig 1300 - 1700 mm, C-shaped	13
03-000577	Assembling jig 800 - 1200 mm, bar type	13
03-000575	Assembling jig 1300 - 1700 mm, bar type	13
03-000579	Assembling jig set 800 - 1200 mm, 2-piece	13
03-000578	Assembling jig set 1300 - 1700 mm, 2-piece	13
03-000462	Mounting tool trapezoidal sheet bracket IR	14
03-000464	Mounting tool trapezoidal sheet bracket IR FL	14
03-000463	Mounting tool trapezoidal sheet bracket elevation profile pair	14



More kilowatts per roof surface
with the flat roof system
from novotegra.

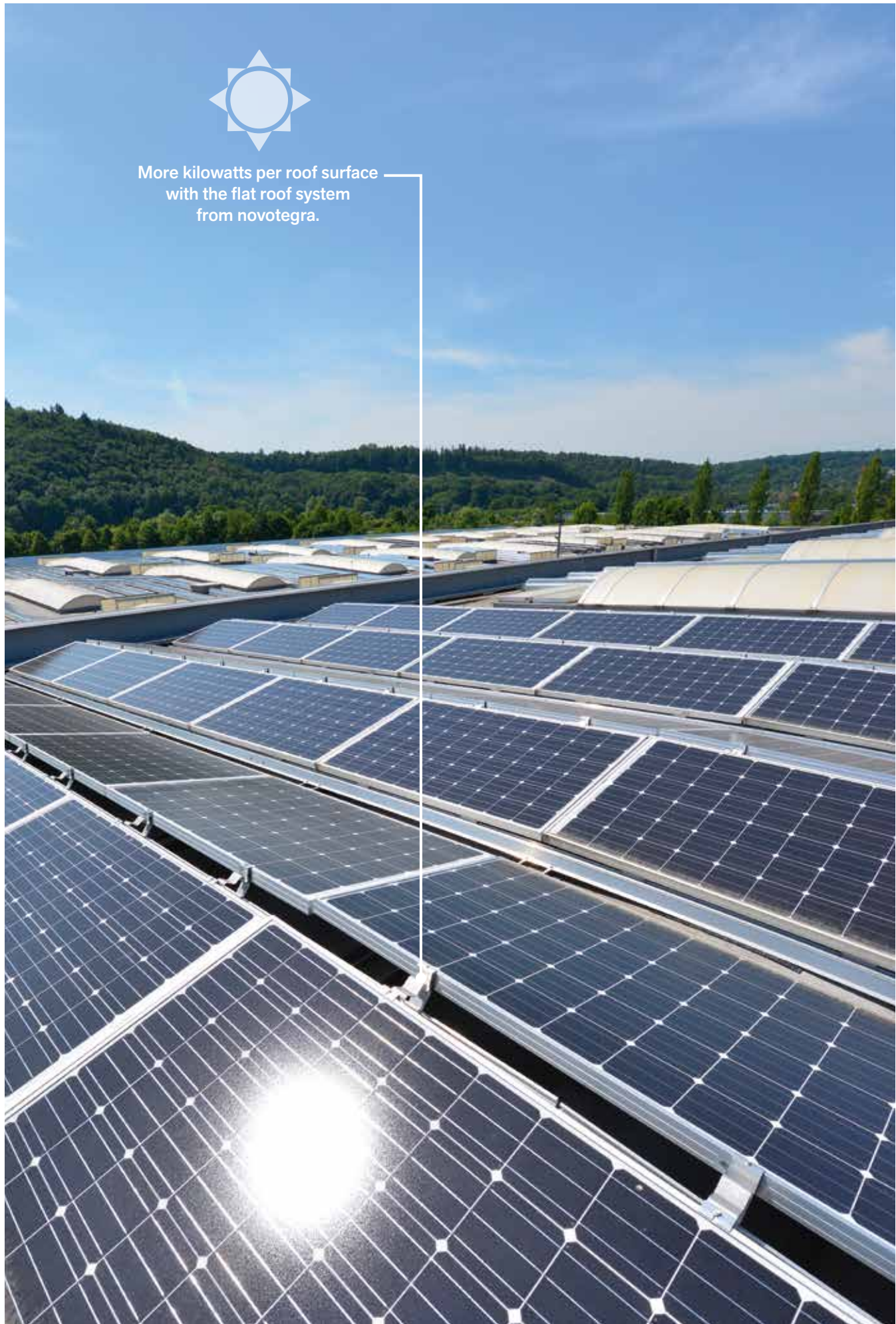

Terms of Guarantee

Product Guarantee for the novotegra Mounting System from BayWa r.e. Solar Energy Systems GmbH

TERMS OF GUARANTEE

Under the following conditions, BayWa r.e. Solar Energy Systems GmbH guarantees that under normal conditions of installation, application, operation and maintenance the components of the novotegra mounting system are free of construction, processing and material defects, for 10 years from the date of receipt.

Only BayWa r.e. Solar Energy Systems GmbH may approve the warranty claim, and only through an independent test on-site. In the case of an approved warranty claim the liability is effected solely through a replacement delivery of the defective component. An approved warranty claim does not lead to an extension of the guarantee period, nor restart it. Subsequent to an accepted warranty claim, no further commitments and liabilities for additional and subsequent damages for BayWa r.e. Solar Energy Systems GmbH exist. Thus a limitation of the legal warranty claims and the legal product liability is not given.

WARRANTY CLAIM

In order to file a claim within 10 years, you must notify BayWa r.e. Solar Energy Systems GmbH in writing within two weeks of the detection of the fault and supply the purchase date, the original order confirmation and delivery note from BayWa r.e. Solar Energy Systems GmbH as proof of purchase. The guarantor is BayWa r.e. Solar Energy Systems GmbH, Eisenbahnstrasse 150, 72072 Tuebingen. The areas covered by this guarantee are based upon German law principles. Furthermore, our general terms and conditions apply in addition to this guarantee.

EXCLUSIONS

Warranty claims under this guarantee cannot be made in the case of:

- Faulty or incorrect installation according to the installation instructions.
- Unauthorised modifications or repairs.
- Inappropriate installation or use of the mounting system.
- Inappropriate transportation, storage or handling of the components.
- Optical deficiencies in so far as the appearance does not have any influence on the performance of the component.
- Incorrect installation according to the static calculations, or installation instructions of other components (for example, the solar module).
- Failure to comply with universally valid norms that have to be respected during installation.
- Damage through e.g. smoke, exceptional thermal stress, salt loading or other chemical products.
- Forces of nature (natural hazard), force majeure, vandalism, destruction through external influences and / or persons / animals.

The cost to BayWa r.e. Solar Energy Systems GmbH for the removal and return of the defective component as well as for the re-assembly of the delivered component are excluded from this guarantee.

Hand-in-hand for your success

Are you looking for a mounting system for a flat roof with a low load reserve,
or want to find out which modules combine best with a certain inverter?
We are happy to help you plan your installation and support you with
our professional expertise.

BayWa r.e. Solar Energy Systems GmbH

Eisenbahnstraße 150, 72072 Tuebingen, Germany
Phone: +49 7071 98987 0
solarenergysystems@baywa-re.com

Sales Office Tuebingen

Eisenbahnstraße 150, 72072 Tuebingen, Germany
Phone: +49 7071 98987 300
tue.solarenergysystems@baywa-re.com

Sales Office Duisburg

Aakerfährstraße 40, 47058 Duisburg, Germany
Phone: +49 203 298776 0
dui.solarenergysystems@baywa-re.com

Sales Office Nuremberg

Wiesentalstraße 32–34, 90419 Nuremberg, Germany
Phone: +49 911 216646 0
nue.solarenergysystems@baywa-re.com

Sales Office Brunswick

Heinrich-Büssing-Ring 25, 38102 Braunschweig, Germany
Phone: +49 531 12177 100
bsg.solarenergysystems@baywa-re.com

Sales Office Munich

Am Haag 10, 82166 Gräfelfing, Germany
Phone: +49 89 383932 3680
mue.solarenergysystems@baywa-re.com

BayWa r.e. Solar Systems Danmark

Kullinggade 31E, 5700 Svendborg, Denmark
Phone: +45 62 21 10 00
solarsystemer@baywa-re.com

BayWa r.e. Solar Systems Filial

Frihamnsallén 8, 211 20 Malmö, Sweden
Phone: +45 62 21 10 00
biuro.ses@baywa-re.com

BayWa r.e. Solar Energy Systems GmbH s. z. o. o.

Krakowska 390, 32-080 Zabierzów, Poland
Phone: +48 574 186 300
biuro.ses@baywa-re.com

You can find all of our subsidiaries and sales offices on our website at www.baywa-re.com under “Locations”.

Imprint

BayWa r.e. renewable energy GmbH

Arabellastraße 4 | 81925 Munich | Phone: +49 89 38 39 32-0 | info@baywa-re.com | www.baywa-re.com

Concept and text BayWa r.e. Solar Energy Systems GmbH, Tuebingen

Design concept Strichpunkt GmbH, Stuttgart | Berlin

Graphics mds Agenturgruppe GmbH

Photography Ben Wiesenfarth, Constance; Reiner Pfisterer, Ludwigsburg

Reproduction BayWa r.e. Solar Energy Systems GmbH, Tuebingen

Printing Mayer & Söhne Druck- und Mediengruppe GmbH & Co. KG, Aichach, Version CA-094.04

Copyright April 2019 BayWa r.e. renewable energy GmbH, Munich. Subject to changes and errors excepted.

Reproduction only permissible on an excerpt basis and with prior written consent from BayWa r.e. renewable energy GmbH.



Remain flexible with a strong network

BAYWA R.E. RENEWABLE ENERGY

BayWa r.e. was founded as a fully owned subsidiary of BayWa AG in 2009. The company combines all of the Group's activities in the field of renewable energies: photovoltaic, wind, biomass and geothermal energy. Today, BayWa r.e. is one of the world's most stable project developers and system providers of PV plants and decentralized energy solutions. The company is currently active in Germany, numerous European countries, USA, Asia-Pacific and Africa.

R.E.THINK ENERGY

BayWa r.e.'s goal is to promote the expansion of renewable energies worldwide. We develop innovative solutions that secure our quality of life. Thanks to the size, global network and financial strength of BayWa AG, we are optimally prepared to fulfill this mission.

BAYWA AG: ACTING FOR THE FUTURE

BayWa is a group with worldwide operations in the core competencies of trading, logistics and services in the segments of Agriculture, Energy, and Building Materials. The head office of the parent company, which was founded in 1923, is located in Munich. The international activities focus on Europe as well as on the US and New Zealand. The company is SDAX listed. BayWa's goal is to shape the future of human needs in an innovative and lasting manner based on trust in its role as a strong partner.



BayWa r.e. Solar Energy Systems GmbH
Eisenbahnstrasse 150
72072 Tuebingen, Germany
Phone +49 7071 98987-0
Fax +49 7071 98987-10
solarenergysystems@baywa-re.com

www.baywa-re.com
solar-distribution.baywa-re.de/en/
novotegra.de