

# 比亚迪储能

## Build Your Dreams

储能行业引领者



Scan the QR Code  
for more information

### Contact

**North America - Michael**  
☎ +1 213-748-3980  
✉ michael.liu@byd.com

**Asia Pacific-Bin Guo**  
☎ +86 18666281028  
✉ guo.bin@fdbatt.com

**Europe(UK) -Luby**  
☎ +86 15725321970  
✉ luby.ni@fdbatt.com

**Middle East&Africa - Helen**  
☎ +86 13556263099  
✉ helen.yu1@fdbatt.com

**ASEAN Countries - Sium Zhang**  
☎ +86 18576670975  
✉ sium.zhang@fdbatt.com

**Southern Europe - Domingo**  
☎ +86 13424216758  
✉ Domingo.zhu@fdbatt.com

**South America - Camilo**  
☎ +86 18026914654  
✉ camilo.ling@fdbatt.com

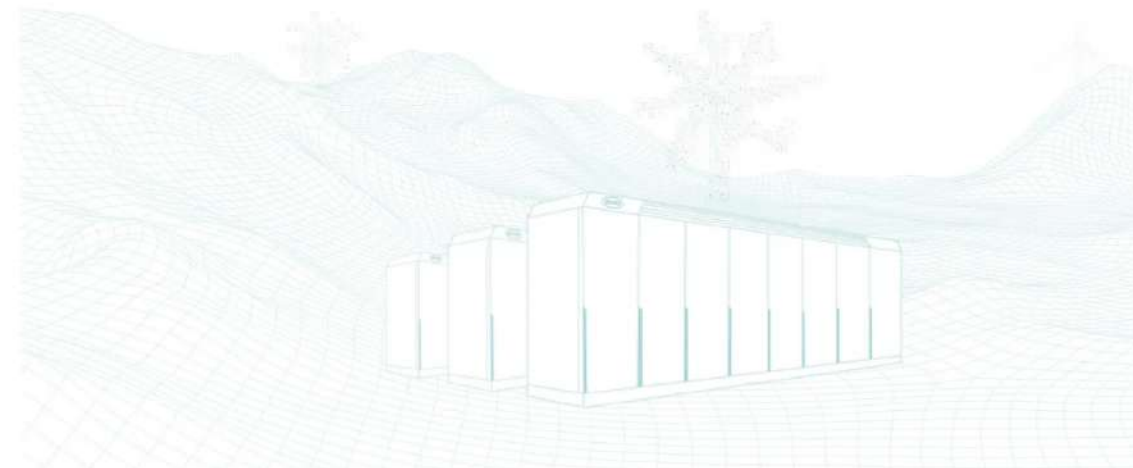

# CONTENTS

## 01 ABOUT US

---

- P 03 About BYD
- P 05 About BYD Energy Storage
- P 07 BYD Energy Storage Milestones

## 02 ADVANTAGES

---

- P 11 R&D Innovation
- P 13 Manufacturing
- P 17 Awards & Honors
- P 18 Cooperation Partners
- P 19 Industrial Landscape

## 03 PRODUCTS

---

- P 23 All-scenarios Application Products
- P 25 Large-scale Energy Storage Products
- P 39 C&I Energy Storage Products
- P 43 Residential Energy Storage Products

## 04 PROJECT CASES

---

- P 49 Project Case-UK
- P 51 Project Case-China
- P 52 Project Case-US

## 05 SERVICE

---

- P 55 Service Concept
- P 55 Global Service Center
- P 56 Battery Recycling

# ABOUT US

01

About BYD

About BYD Energy Storage

BYD Energy Storage Milestones

## About BYD



### TECHNOLOGICAL INNOVATIONS FOR A BETTER LIFE

BYD Company Limited ("BYD") was established in February, 1995 with its headquarter in Shenzhen, Guangdong Province. BYD employs 450,000 people and operates across four industries: Auto, Rail Transit, New Energy and Electronics. BYD is listed in Hongkong and Shenzhen. In 2008, BYD proposed Three Green Dreams of Solar, Energy Storage and EV. BYD is committed to the interconnection with all links from energy absorption, storage to application and continues to provide technological innovations for a better life.

# About BYD Energy Storage

**2008**  
Since

**400**  
Cities

**14<sup>GWh</sup>**  
Delivered

**“0”**  
“0” Safety Accident  
In 16 Years

BYD Energy Storage was established in 2008. As a global pathfinder, leader and expert in battery energy storage system, BYD Energy Storage specializes in the R&D, manufacturing, marketing, service and recycling of the energy storage products. Built on the state-of-the-art battery technology, BYD Energy Storage has provided safe and reliable energy storage system solutions for hundreds of Grid-scale, C&I and residential energy storage projects worldwide, covering 400+ cities, 70+ countries and regions, 6 continents, including the U.S., U.K., Germany, France, Switzerland, Italy, Japan. Total global shipment volume has reached 14GWh+ (As of Dec.31, 2022) . BYD Energy Storage will collaborate with you for a clean and sustainable future.

# BYD Energy Storage Milestones



# ADVANTAGES

02

R&D Innovation

Manufacturing

Awards & Honors

Cooperation Partners

Industrial Landscape

Technology Based,  
Innovation Oriented

## R&D Innovation

27 Years  
Experience



37000+  
Patent System

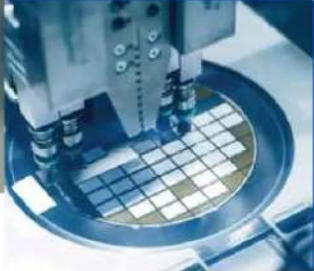

45000+  
R&D Personnel



## MULTIPLE SAFETY TESTS



External Fire Exposure



Vibration



Nail Penetration



Impact



Heating



Crush

## Magic Cloud e.0

/Algorithm and Control Platform



### Remote Upgrading

OTA remote upgrading, access to latest services

### One-key Remote Start

Commissioning free, less site work

### Smart Algorithm

SOX calculation with high precision based on the mass data analysis and smart BMS with the cloud-terminal computing power

### Cloud Fault Diagnosis

System fault diagnosis with one touch, intelligently push the solutions to realize the fast commissioning and maintenance



# Manufacturing

## No Worries to Use Batteries

BYD Blade Battery is the world's only battery which has passed the nail penetration test, ends the industry pain points and establishes the safety benchmark.

## Ultra Safety & Ingenious Design



### Ultra Low Cost

Compared with the traditional battery pack, the space utilization rate is increased by 20%, and the comprehensive LCOE is reduced by 30%



### Ultra Safety

Intelligent chip control, active and passive protection to deal with various emergencies



### Ultra Long Lifecycle

LFP chemistry, life up to 12000 cycles



### Ultra High Strength

Honeycomb-like aluminum plate structure design to ensure structural strength



### Ultra High Energy Density

No-Pack design, space saving to realize the ultra high energy density



### Ultra Power

Voltage output up to 1500V and peak current up to 238A at full power



### Ultra Low Temperature Performance

Operate efficiently at -30°C and maintain the optimal state

# Manufacturing



## Energy Storage Battery Whole Industrial Chain Layout

All-round R&D layout of energy storage battery based on the R&D of basic materials, battery performance as the center, and innovative technology-oriented.

-   
**Automation**
-   
**Smart**
-   
**Digitization**
-   
**One-stop**

## Awards & Honors



## Cooperation Partners



# Industrial Landscape



# PRODUCTS

# 03

## All-scenarios Application Products

MC CUBE

## Large-scale Energy Storage Products

MC CUBE ESS

CUBE

BYD 20ft ESS

Containerized ESS

Non-isolated Bi-directional PCS

Modularized PCS

## C&I Energy Storage Products

CHESS

CHESS Pro

## Residential Energy Storage Products

Energy Pod

Energy Panel

Safe & Reliable  
Green Development

# MC Cube

MC-B536-E-R4M01  
MC-B466-E-R2M01



World's first BESS using the Blade Battery, highly integrated with ultra high energy density.

## SYSTEM FEATURES



### Safe & Reliable

Pass 10+ destructive tests such as short-circuit, vibration, external fire exposure, four-level active and passive protection



### Flexible & Configurable

Compliant with global energy storage standards, quick connector design to save the time, flexible augmentation, possible for mixed use of new and old batteries



### Cost-efficient & Smart

Maximized the overall energy density, space saving; interconnected with the cloud system for the real-time monitoring

## CIRCUIT DIAGRAM

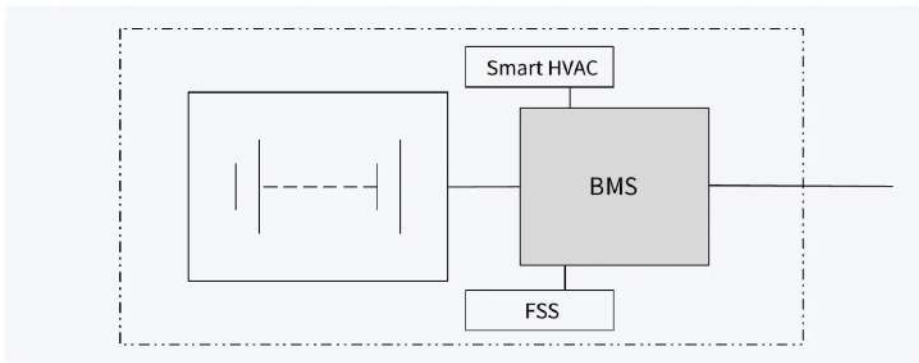

## System Parameters

System Type	MC-B536-E-R4M01	MC-B466-E-R2M01
<b>DC Side</b>		
Cell Type	LFP	LFP
String Type	1P416S	1P416S
System Configuration	1×1P416S	1×1P416S
Battery Capacity (BOL)	536kWh	466kWh
DC Usable Energy (BOL)@FAT	515kWh	447kWh
DC Usable Energy (BOL)@SAT	500kWh	434kWh
Battery Voltage Range	1081.6 ~ 1497.6V	1081.6 ~ 1497.6V
Nominal Power	125kW	217kW
<b>General Parameters</b>		
Dimensions(W×D×H)	1130×1203×2521mm	1130×1203×2521mm
Weight	≈3784kg	≈3817kg
IP Rating	IP55	IP55
Operating Ambient Temperature	-30°C~+55°C 【1】	-30°C~+55°C 【1】
Relative Humidity	5%~100%	5%~100%
Max. Working Altitude	< 2000m	< 2000m
Cooling Concept	Smart Air Cooling	Liquid Cooling
Noise	≤75dB(A)	≤75dB(A)
Fire Suppression System	With fire alarm system(Aerosol optional)	With fire alarm system(Aerosol optional)
Communication Interfaces	CAN	CAN
Communication Protocols	OD	OD
Standard Color	RAL9003	RAL9003
Compliance	UN38.3,UN3536,UL9540A,UL1973,IEC62619	

Note:

【1】 Power derating is performed when the ambient temperature is below -15°C or above 45°C.

# MC Cube ESS

MC10C-B5365-E-R4M01  
MC10C-B4659-E-R2M01



World's first BESS using the Blade Battery, highly integrated with ultra high energy density, flexible configuration and easy for transportation, layout, installation, augmentation and maintenance.

## SYSTEM FEATURES



### Professional & Smart

Vehicle regulation Temperature control/electronic control solution compliant with vehicle standards, cloud-terminal smart battery management algorithm.



### Ultra High Safety

Zero safety accident in 15 years, UL9540A certified.



### Reliable & Stable

Extreme battery strength, long lifecycle. Cloud intelligent service, latest upgrading.

## CIRCUIT DIAGRAM

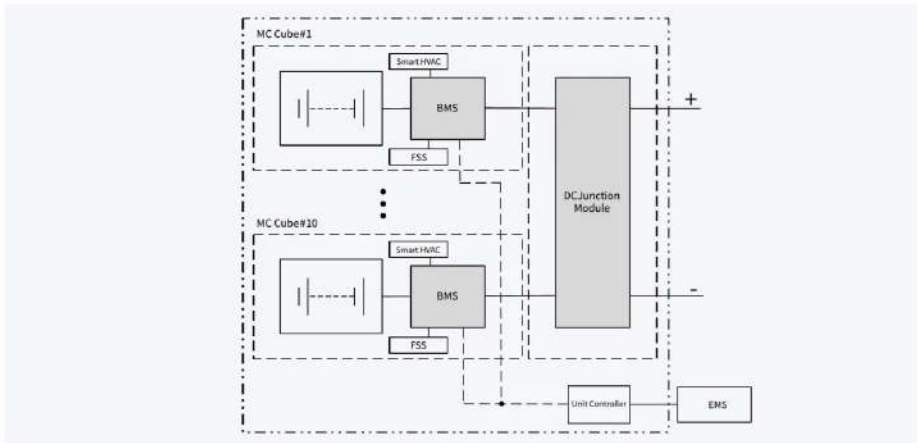

## SYSTEM PARAMETERS

System Type	MC10C-B5365-E-R4M01	MC10C-B4659-E-R2M01
<b>DC Side</b>		
Cell Type	LFP	LFP
String Type	1P416S	1P416S
System Configuration	10×1P416S	10×1P416S
Battery Capacity (BOL)	5365kWh	4659kWh
DC Usable Energy(BOL)@FAT	5099kWh	4428kWh
DC Usable Energy (BOL)@SAT	4946kWh	4295kWh
Battery Voltage Range	1081.6 ~ 1497.6V	1081.6 ~ 1497.6V
Nominal Power	1236kW	2147kW

### General Parameters

Dimensions(W×D×H)	6058×2438×2896mm	6058×2438×2896mm
Weight	≈41035kg	≈41385kg
IP Rating	IP55	IP55
Operating Ambient Temperature	-30°C~+55°C 【1】	-30°C~+55°C 【1】
Relative Humidity	5%~100%	5%~100%
Max. Working Altitude	< 2000m	< 2000m
Cooling Concept	Smart Air Cooling	Liquid Cooling
Noise	≤75dB(A)	≤75dB(A)
Fire Suppression System	With fire alarm system(Aerosol optional)	With fire alarm system(Aerosol optional)
Communication Interfaces	Ethernet	Ethernet
Communication Protocols	Modbus TCP/IP	Modbus TCP/IP
Standard Color	RAL9003	RAL9003
Compliance	UN38.3,UN3536,UL9540A,UL1973,IEC62619	

Note:

【1】 Power derating is performed when the ambient temperature is below -15°C or above 45°C.

# CUBE Pro

CP36-B2800-E-R1M01 & CP32-B2800-E-R2M01 & CP32-B3000-E-R4M01

World's first liquid-cooled battery energy storage system that has passed UL9540A and GB36276 tests.



## SYSTEM FEATURES

**Small Space & High Energy Density**  
Compact mechanical design, minimized footprint.

**Liquid Cooling & Stable System**  
Equipped with an efficient and reliable liquid cooling system, the battery temperature difference is less than 3°C during operation.

**Advanced Technology & Efficient and Safe**  
Using the advanced LFP batteries, longer service life. Equipped with FSS to ensure safe operation.

**Highly Integrated & Easy for Installation**  
Highly integrated system, all-in-one design, integrated local controller, HVAC and FSS, easy for installation and transportation.

## CIRCUIT DIAGRAM

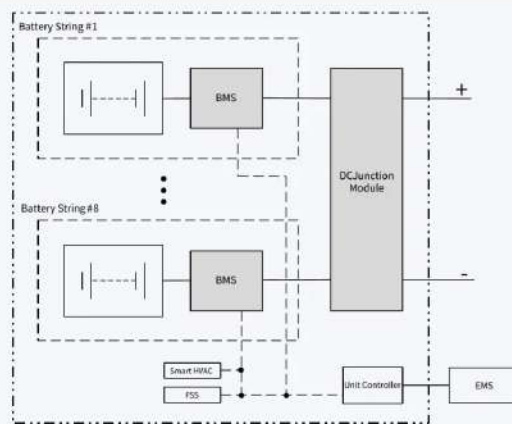

## SYSTEM PARAMETERS

System Type	CP36-B2800-E-R1M01	CP32-B2800-E-R2M01	CP32-B3000-E-R4M01
<b>DC Side</b>			
Cell Type	LFP C15	LFP C15	LFP C15
Pack Type	1P114S	1P114S	1P114S
Rack Size	1P228S (2 packs)	1P342S (3 packs)	1P342S (3 packs)
System Configuration	12×1P228S	8×1P342S	8×1P342S
Battery Capacity (BOL)	2800kWh	2800kWh	3000kWh
DC Usable Energy (BOL)@SAT	2560kWh	2590kWh	2835kWh
DC Energy at Full Power (BOL)@SAT	2430kWh	2590kWh	2750kWh
Battery Voltage Range	638.4~820.8V	934~1231.2V	934~1231.2V
Nominal Power	2430kW	1245kW	625kW
<b>General Parameters</b>			
Dimensions(W×D×H)	11000×1700×2645mm	9800×1700×2645mm	9800×1700×2645mm
Weight	31000kg	29500kg	29000kg
IP Rating	IP55	IP55	IP55
Operating Ambient Temperature range	-30°C~+55°C【1】	-30°C~+55°C【1】	-30°C~+55°C【1】
Relative Humidity	5%~100%	5%~100%	5%~100%
Max. Working Altitude	< 3000m	< 3000m	< 3000m
Cooling Concept	Liquid cooling	Liquid cooling	Liquid cooling
Noise	≤80dB(A)@1m	≤75dB(A)@1m	≤75dB(A)@1m
Fire Suppression System(optional)	Heptafluoropropane/perfluorohexanone/reserved water fire pipeline	Heptafluoropropane/perfluorohexanone/reserved water fire pipeline	Heptafluoropropane/perfluorohexanone/reserved water fire pipeline
Aux. Power Interface	AC400V/50Hz, 3-phase 4-wire	AC400V/50Hz, 3-phase 4-wire	AC400V/50Hz, 3-phase 4-wire
Aux. System Peak Power Requirement @45°C, PF0.8	50.70kW	32.70kW	11.60kW
Communication Interfaces	Ethernet	Ethernet	Ethernet
Communication Protocols	Modbus TCP/IP	Modbus TCP/IP	Modbus TCP/IP
Standard Color	RAL9003	RAL9003	RAL9003
Compliance	UN38.3,UL9540A,UN3536,UL1642,IEC62619,CE Marking,UKCA,IEC63056		

Note:  
【1】 Power derating is performed when the ambient temperature is above 40°C.



# BYD-20ft ESS

CS20H-B3168-E-R2M01  
CS20H-B2982-E-R1M01

The 20-foot container compacts with the dimension of standard shipping container, carries the BMS technology platform of MC Cube products, can be available for 1/2/8 outputs and match with different PCS, fills the 1C/0.5C application of MC Cube products, rationalize the module size to effectively reduce maintenance space.



## SYSTEM FEATURES



**Lower Shipping Cost**  
20 feet standard container size.  
Weight less than 35T.



**Flexible Configuration**  
8 strings of batteries can be independently output.  
Centralized combined application is also available.

## CIRCUIT DIAGRAM

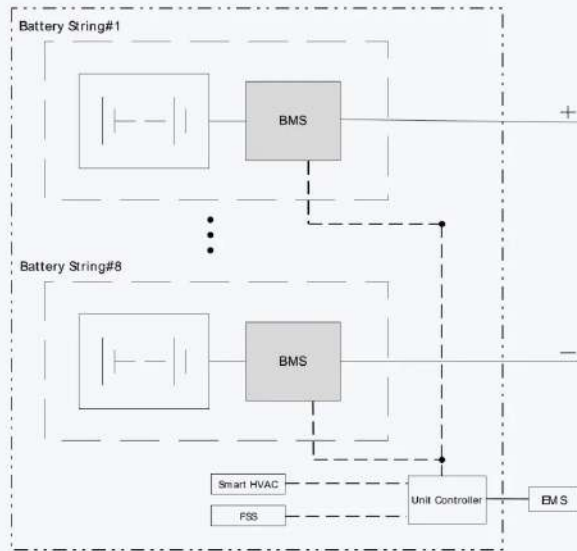

## SYSTEM PARAMETERS

System Type	CS20H-B3168-E-R2M01	CS20H-B2982-E-R1M01
<b>DC Data</b>		
Cell type	LFP C15-340Ah	LFP C15-320Ah
Pack type	1P52S	1P52S
Rack size	1P364S (7 Packs)	1P364S (7 Packs)
System configuration	8 × 1P364S	8 × 1P364S
Battery capacity (BOL)	3168kWh	2982kWh
DC usable energy (BOL) @FAT	2946kWh	2713kWh
DC usable energy (BOL) @SAT	2857kWh	2631kWh
Battery voltage range	946.4 ~ 1310.4V	946.4 ~ 1310.4V
Nominal power	1428.5kW	2631kW

### General Data

	Standard HQ	Standard HQ
Cabinet Type	Standard HQ	Standard HQ
Dimension (W×D×H)	6058×2438×2896mm	6058×2438×2896mm
Weight	< 35T	< 35T
IP rating	IP55	IP55
Anti-corrosion Grade	C4	C4
Operating ambient temperature range	-30°C ~ +55°C [1]	-30°C ~ +55°C [1]
Relative humidity	5% ~ 100%	5% ~ 100%
Max. Working altitude	≤2000m [2]	≤2000m [2]
Cooling concept	Liquid cooling	Liquid cooling
Noise	≤75dBA	≤75dBA
Fire suppression system	NOVEC1230/FM200/Water Sprinkler System [3]	
Auxiliary system nominal power	27kW	52kW
Auxiliary system voltage	400V	400V
Auxiliary system wiring	3P4W	3P4W
Auxiliary system peak power requirement @45°C, PF=0.8	33.75kVA	65kVA
Communication interfaces	Ethernet	Ethernet
Communication protocols	Modbus TCP/IP	Modbus TCP/IP
Standard color	RAL 9003	RAL 9003
Compliance	UN38.3, UN3536, UKCA, CE Marking, IEC62619, IEC63056	

Annotation:

[1] Power derating when environment temperature is lower than -15°C or higher than 40°C.

[2] When the altitude is between 2000-3000m, the output of the system will be de-rated.

[3] FM200/NOVEC1230 and water spray system are optional.

# Containerized ESS (MV)

CS40HN-P4000B4608-E (MV) & CS40HN-P4000B9216-E (MV) & CS40HN-P4000B13824-E (MV) & CS40HN-P4000B18432-E (MV)

Highly integrated battery container, PCS and MV transformer to provide customers with a complete turnkey energy storage system.



## SYSTEM FEATURES



### Highly Integrated & Cost-effective

Integrate core equipment such as PCS, LFP batteries, RMU, transformer, local controller, all-in-one design and total delivery Cell-level precise temperature control, intelligent charge and discharge management, longer battery cycle life.



### Unified Management & Safe and Reliable

Integrate the local controller, unify the communication interfaces and protocols to realize the comprehensive management of equipment. AC side online insulation detection, four-level fuse, five-level linkage protection design. Intelligent fire suppression system, multi-point monitoring and early warning.

## CIRCUIT DIAGRAM

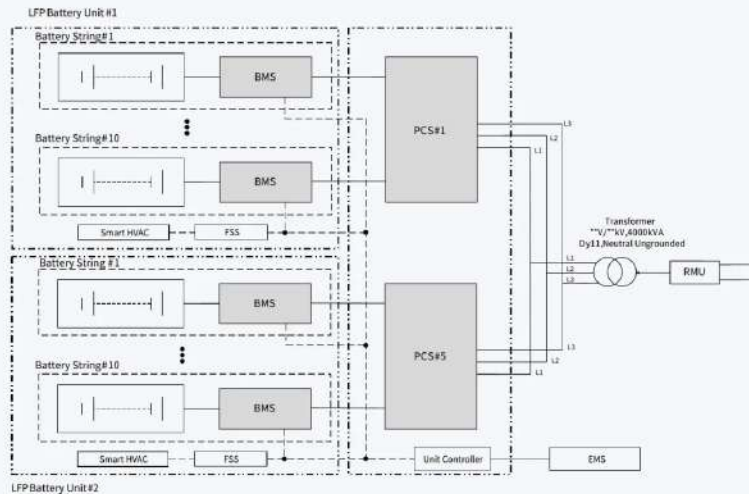

## SYSTEM PARAMETERS

System Type	CS40HN-P4000B4608-E(MV)	CS40HN-P4000B9216-E(MV)	CS40HN-P4000B13824-E(MV)	CS40HN-P4000B18432-E(MV)
<b>DC Side</b>				
Cell Type	LFP C15	LFP C15	LFP C15	LFP C15
Module Type	1P9S	1P9S	1P9S	1P9S
String Type	1P225S (25 Modules)	1P225S (25 Modules)	1P225S (25 Modules)	1P225S (25 Modules)
System Configuration	20x1P225S	40x1P225S	60x1P225S	80x1P225S
Initial Battery Nominal Energy	4608kWh	9216kWh	13824kWh	18432kWh
Battery Voltage Range	630~810V	630~810V	630~810V	630~810V
<b>AC Side</b>				
Nominal Power	4000kVA	4000kVA	4000kVA	4000kVA
AC Usable Energy @FAT	4160kWh	8410kWh	12615kWh	16820kWh
Nominal Voltage/ Voltage Range	400V/360~440V	400V/360~440V	400V/360~440V	400V/360~440V
Power Factor	0.95(lagging)~0.95(leading)	0.95(lagging)~0.95(leading)	0.95(lagging)~0.95(leading)	0.95(lagging)~0.95(leading)
THD	<3% (rated power)	<3% (rated power)	<3% (rated power)	<3% (rated power)
<b>Transformer Output Parameters</b>				
Rated Power	4000kVA	4000kVA	4000kVA	4000kVA
AC Usable Energy (BOL)@FAT	4115kWh	8325kWh	12485kWh	16650kWh
AC Energy at Full Power (BOL)@FAT	3909kWh	8325kWh	12485kWh	16650kWh
Nominal Grid Frequency	50Hz	50Hz	50Hz	50Hz
Grid Frequency Range	47~52Hz	47~52Hz	47~52Hz	47~52Hz
LV / MV Voltage	0.4kV/10~35kV(Dy11)	0.4kV/10~35kV(Dy11)	0.4kV/10~35kV(Dy11)	0.4kV/10~35kV(Dy11)
<b>General Parameters</b>				
Dimensions of Battery Container (W×D×H)	12192x2438x2896mm	12192x2438x2896mm	12192x2438x2896mm	12192x2438x2896mm
Dimensions of MV Container (W×D×H)	12192x2438x2896mm	12192x2438x2896mm	12192x2438x2896mm	12192x2438x2896mm
Battery Container Weight	29000kg	29000kg	29000kg	29000kg
MV Container Weight	16000kg	16000kg	16000kg	16000kg
IP Rating	IP54	IP54	IP54	IP54
Operating Ambient Temperature	-20°C~+45°C【1】	-20°C~+45°C【1】	-20°C~+45°C【1】	-20°C~+45°C【1】
Relative humidity	5%~95%	5%~95%	5%~95%	5%~95%
Max. Working Altitude	3000m	3000m	3000m	3000m
Cooling Concept(PCS)	Forced air cooling	Forced air cooling	Forced air cooling	Forced air cooling
Cooling Concept (Battery Container)	Smart Air Cooling	Smart Air Cooling	Smart Air Cooling	Smart Air Cooling
Fire Suppression System (Battery Container)	Heptafluoropropane or perfluorohexanone	Heptafluoropropane or perfluorohexanone	Heptafluoropropane or perfluorohexanone	Heptafluoropropane or perfluorohexanone
Communication Interfaces	Ethernet	Ethernet	Ethernet	Ethernet
Communication Protocols	Modbus TCP/IP	Modbus TCP/IP	Modbus TCP/IP	Modbus TCP/IP
Compliance	IEC62619,UL1642,UL1973,UL9540A			
Standard Color	RAL9003/RAL6012	RAL9003/RAL6012	RAL9003/RAL6012	RAL9003/RAL6012

Note:

【1】 Power derating is performed when the ambient temperature is above 45°C.

# Containerized ESS (LV)

CS40HN-P4000B4608-E & CS40HN-P4000B9216-E & CS40HN-P4000B13824-E & CS40HN-P4000B18432-E

Highly integrated battery container, PCS to provide customers with AC low-voltage grid-connected energy storage system.



## SYSTEM FEATURES



### Highly Integrated & Cost-effective

Integrate core equipment such as PCS, LFP batteries, RMU, transformer, local controller, all-in-one design and total delivery Cell-level precise temperature control, intelligent charge and discharge management, longer battery cycle life.



### Unified Management & Safe And Reliable

Integrate the local controller, unify the communication interfaces and protocols to realize the comprehensive management of equipment.AC side online insulation detection, four-level fuse, five-level linkage protection design. Intelligent fire suppression system, multi-point monitoring and early warning.

## CIRCUIT DIAGRAM

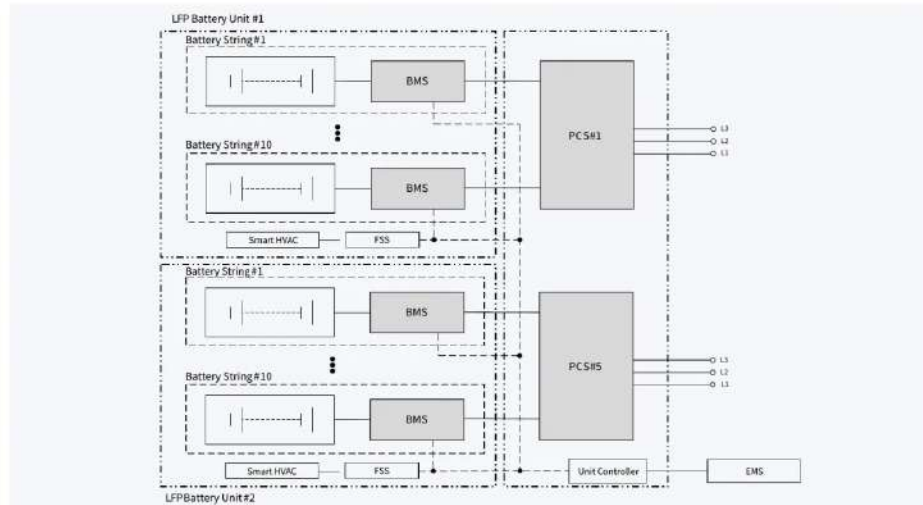

## SYSTEM PARAMETERS

System Type	CS40HN-P4000B4608-E	CS40HN-P4000B9216-E	CS40HN-P4000B13824-E	CS40HN-P4000B18432-E
<b>DC Side</b>				
Cell Type	LFP C15	LFP C15	LFP C15	LFP C15
Module Type	1P9S	1P9S	1P9S	1P9S
String Type	1P225S(25 Modules)	1P225S(25 Modules)	1P225S(25 Modules)	1P225S(25 Modules)
System Configuration	20x1P225S	40x1P225S	60x1P225S	80x1P225S
DC Usable Energy (BOL)@FAT	4245kWh	8582kWh	12872kWh	17163kWh
Battery Voltage Range	630~810V	630~810V	630~810V	630~810V
<b>AC Side</b>				
Nominal Power	4000kVA	4000kVA	4000kVA	4000kVA
AC Usable Energy (BOL)@FAT	4160kWh	8410kWh	12615kWh	16820kWh
AC Energy at Full Power (BOL)@FAT	3952kWh	8410kWh	12615kWh	16820kWh
Nominal Voltage/Voltage Range	400V/360~440V	400V/360~440V	400V/360~440V	400V/360~440V
Nominal Grid Frequency/ Grid Frequency Range	50Hz/47~52Hz	50Hz/47~52Hz	50Hz/47~52Hz	50Hz/47~52Hz
Power Factor	0.95(lagging)~0.95(leading)	0.95(lagging)~0.95(leading)	0.95(lagging)~0.95(leading)	0.95(lagging)~0.95(leading)
THD	<3% (@Nominal)	<3% (@Nominal)	<3% (@Nominal)	<3% (@Nominal)
Isolation Method	Transformer-less	Transformer-less	Transformer-less	Transformer-less
<b>General Parameters</b>				
Dimensions (Container) (W×D×H)	12192x2438x2896mm	12192x2438x2896mm	12192x2438x2896mm	12192x2438x2896mm
Dimensions (PCS) (W×D×H)	1510x1350x2300mm	1510x1350x2300mm	1510x1350x2300mm	1510x1350x2300mm
Battery Container Weight	29000kg	29000kg	29000kg	29000kg
PCS Weight	1350kg	1350kg	1350kg	1350kg
IP Rating	IP54	IP54	IP54	IP54
Operating Ambient Temperature	-20°C~+45°C【1】	-20°C~+45°C【1】	-20°C~+45°C【1】	-20°C~+45°C【1】
Relative Humidity	5%~95%	5%~95%	5%~95%	5%~95%
Max. Working Altitude	< 3000m	< 3000m	< 3000m	< 3000m
Cooling Concept (PCS)	Forced air cooling	Forced air cooling	Forced air cooling	Forced air cooling
Cooling Concept (Battery Container)	Smart Air Cooling	Smart Air Cooling	Smart Air Cooling	Smart Air Cooling
Fire Suppression System	HFC-227ea Fire Extinguishing	HFC-227ea Fire Extinguishing	HFC-227ea Fire Extinguishing	HFC-227ea Fire Extinguishing
Communication Interfaces	Ethernet	Ethernet	Ethernet	Ethernet
Communication Protocols	Modbus TCP/IP	Modbus TCP/IP	Modbus TCP/IP	Modbus TCP/IP
Compliance	IEC62619,UL1642,UL1973,UL9540A			
Standard Color	RAL9003/RAL6012	RAL9003/RAL6012	RAL9003/RAL6012	RAL9003/RAL6012

Note:  
【1】 Power derating is performed when the ambient temperature is above 45°C.

# Non-isolated Bi-directional PCS BEG60KTL-U-R1

String-type energy storage inverter to realize flexible configuration and management of battery system.



## SYSTEM FEATURES

**Efficient Conversion & Smart Air Cooling**  
Max. efficiency 98.76%, smart air cooling, no derating at 45°C.

**Convenient Transportation & Safe and Reliable**  
Modular design, highly reliable transportation and maintenance. Outdoor design and simple site work. High IP rating, full-film capacitors for longer life; RACK-level battery management to reduce the number of batteries connected in series and in parallel.

**Authoritative Certification & Quality Reliable**  
Pass the UL and CSA certification, quality reliable.

## CIRCUIT DIAGRAM

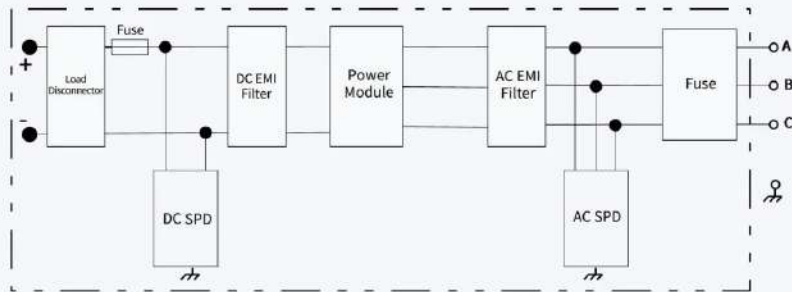

## SYSTEM PARAMETERS

System Type	BEG60KTL-U-R1
<b>DC Side</b>	
DC Voltage	750-1000Vdc
Max. DC Current	80A
<b>AC Side</b>	
Rated AC Voltage	400Vac
Voltage Range	360Vac~440Vac
Max. AC Current	80A
Rated Power	50kVA
Rated Frequency	50Hz
Grid Frequency Range	47~50.5Hz
Power Factor	1(lagging)~1(leading)
THD	<3%@Rated Voltage
Response Time	<50ms
<b>System Parameters</b>	
Isolation Method	Transformer
Max. Efficiency	>98%
IP Rating	IP65
Operating Ambient Temperature	-25°C~+60°C (Start derating operation above +50°C)
Relative Humidity	0~100%(non-condensing)
Max. Working Altitude	<3000m
Noise	<65dB(A)@1m
Cooling Concept	Air Cooling
Display	LED
Communication Interfaces	Ethernet/CAN/RS485
Communication Protocols	ModbusTCP/IP
Dimensions(W×D×H)	930mm×580mm×275mm
Weight	<65 kg
<b>Protection</b>	
Short Circuit Protection	Yes
Overload Protection	Yes
Grid Monitoring	Yes
Over-voltage/Over-current Protection	Yes
Over-temperature Protection	Yes
DC Electrode Positive Protection	Yes
<b>Function</b>	
P/Q	Yes
LVRT	Yes

# Modularized PCS BEM842KTL-E BEM800KTL-E

Modular design, faster maintenance and replacement to improve system utilization.



## SYSTEM FEATURES



### Efficient Conversion

Max. efficiency 98.76%, smart air cooling, no derating at 45°C, THD<2%@rated power.



### Convenient O&M

Modular design, highly reliable O&M, outdoor cabinet design, simple site work.



### Flexible Application

Four-quadrant operation with battery charge and discharge management function, built-in auxiliary power supply, response time ≤ 50ms.



### Safe and Reliable

High IP rating (IP54, C4), full-film capacitors for longer life, RACK-level battery management to reduce the number of batteries connected in series and in parallel.

## CIRCUIT DIAGRAM

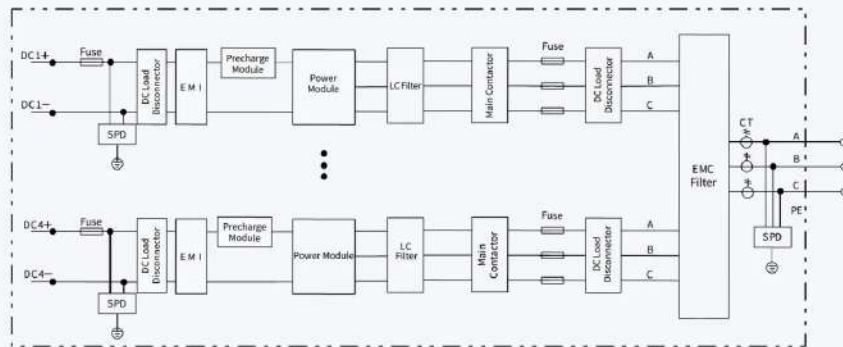

## SYSTEM PARAMETERS

System Type	BEM842KTL-E	BEM800KTL-E
<b>DC Side</b>		
DC Voltage Range	650~850Vdc	650~850Vdc
Max. DC Power	926kW	880kW
DC Input Channels	4	4
<b>AC Side(On-grid)</b>		
Rated AC Power	842kVA	800kVA
Max. AC power	926kW	880kW
Rated Grid Frequency/Grid Frequency Range	50Hz/47~52Hz	50Hz/47~52Hz
Rated AC Voltage/AC Voltage Range	400Vac/360Vac~440Vac	400Vac/360Vac~440Vac
Rated AC Current	1215A	1155A
Max. AC Current	1337A	1270A
THD	<2% (@rated power, Uthd < 1%)	<2% (@rated power, Uthd < 1%)
Power Factor	1(lagging)~1(leading)	1(lagging)~1(leading)
Reactive Power Range	-842kVar~+842kVar	-800kVar~+800kVar
Response Time	<50ms	<50ms
<b>Efficiency</b>		
Max. Efficiency	98.76%(Without aux. power consumption)	98.76%(Without aux. power consumption)
<b>Protection</b>		
Short Circuit Protection	Yes	Yes
Overload Protection	Yes	Yes
Over-voltage/Over-current Protection	Yes	Yes
Grid Monitoring	Yes	Yes
Over-temperature Protection	Yes	Yes
DC Input Protection	Yes	Yes
<b>System Parameters</b>		
Isolation Method	Transformer-less	Transformer-less
Distribution Network Type	IT	IT
IP Rating	IP54	IP54
Operating Ambient Temperature	-20°C~+55°C@>45°C, de-rating 3.125%/K	-20°C~+55°C@>45°C, de-rating 3.125%/K
Relative Humidity	5~95%(non-condensing)	5~95%(non-condensing)
Max. Working Altitude	3000m	3000m
Chemically Active Substances	C4, Referring to IEC 60721-3-4	C4, Referring to IEC 60721-3-4
Noise	<76dB(A)@ 1 m	<76dB(A)@ 1 m
Cooling Concept	Smart forced air cooling	Smart forced air cooling
Aux. Power Consumption (Max./Standby/Stop)	1920W/237W/140W	1920W/237W/140W
Fresh Air Consumption	4000m³/h	4000m³/h
Display	HMI touch display	HMI touch display
Communication Interfaces	Ethernet/CAN	Ethernet/CAN
Communication Protocols	Modbus TCP/IP	Modbus TCP/IP
Dimensions(W×D×H)	1510mm×1350mm×2300mm	1510mm×1350mm×2300mm
Weight	~ 1350kg	~ 1350kg
Compliance	G99/CE	G99/CE
Grid Support	LVRT, P/Q, islanding protection (active and passive detection)	

# CHESS

OSN-P120B274-U  
OSN-P60B274-U



All-in-one C&I Energy Storage System, applicable to diversified scenarios.

## SYSTEM FEATURES



### Smart Management & Production Safety

The battery string is broken into small units that do not exceed the nominal voltage of 374.4V, which is easy to manage and reduces maintenance costs.



### Flexible Configuration & Easy Installation

Using high-capacity LFP battery, improved energy storage, and longer cycle life.



### Hierarchical Linkage & Economical and Reliable

Independent intelligent BMS, matching with battery characteristics, more extensive application scenarios.

## CIRCUIT DIAGRAM

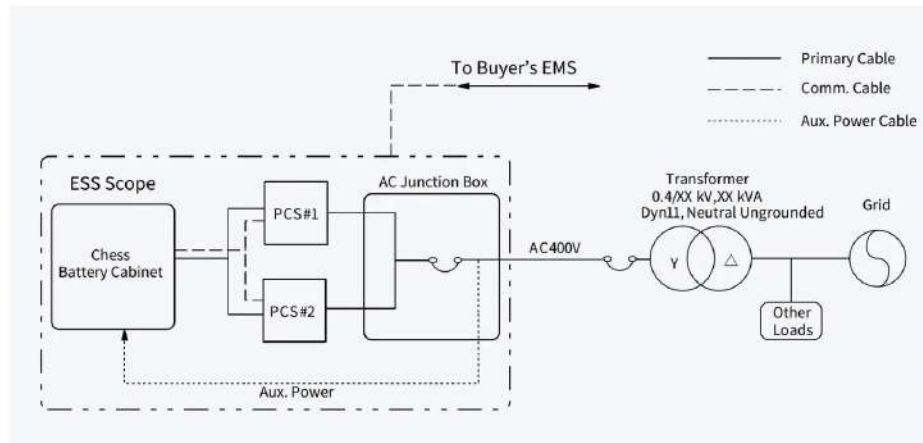

## SYSTEM PARAMETERS

System Type	OSN-P120B274-U	OSN-P60B274-U
<b>DC Side</b>		
Cell Type	LFP C15	LFP C15
Module type	1P9S	1P9S
String Type	1P252S(28 Modules)	1P252S(28 Modules)
System Configuration	1X1P252S	1X1P252S
Battery Nominal Capacity (BOL)	266kWh	266kWh
DC Usable Energy (BOL)@FAT	247kWh	247kWh
Battery Voltage Range	705.6-907.2V	705.6-907.2V
<b>AC Side</b>		
Rated Power	100kVA@400Vac	50kVA@400Vac
AC Usable Energy (BOL) @FAT	240kWh	240kWh
AC Energy at Full Power (BOL)@FAT	240 kWh	240 kWh
Rated Voltage	400V/50Hz	400V/50Hz
Voltage Range	360V ~ 440V	360V ~ 440V
Nominal Grid Frequency	50Hz	50Hz
Grid Frequency Range	47Hz ~ 50.5Hz	47Hz ~ 50.5Hz
Power Factor	1(lagging)~1(leading)	1(lagging)~1(leading)
THD	<3% (@rated power)	<3% (@rated power)
Isolation Method	Transformer-less	Transformer-less
<b>General Parameters</b>		
Dimensions(W×D×H)	1600×1900×2300 mm	1600×1900×2300 mm
Weight	~ 3200kg	~ 3100kg
IP Rating (PCS Cabinet)	IP65	IP65
IP Rating (Battery Cabinet)	IP55	IP55
Operating Ambient Temperature	-20°C~+55°C [1]	-20°C~+55°C [1]
Relative Humidity	5%~100%	5%~100%
Max. Working Altitude	3000m	3000m
Cooling Concept (PCS Cabinet)	Forced air cooling	Forced air cooling
Cooling Concept (Battery Cabinet)	Air-cooled air conditioner	Air-cooled air conditioner
Noise	≤75dB(A)@1m	≤75dB(A)@1m
Fire Suppression System	With fire detection gas fire extinguishing system	With fire detection gas fire extinguishing system
Aux. Power Interface	AC400V/50Hz, 3 phase(L1/L2, 2 wires)	AC400V/50Hz, 3 phase(L1/L2, 2 wires)
Aux. System Peak Power Requirement	3.5kW	3.5kW
Communication Interfaces	Ethernet	Ethernet
Communication Protocols	Modbus TCP/IP	Modbus TCP/IP
Compliance	IEC62619,UL1642,UL1973,UL9540,UL9540A,UL1741 SA	

Note:

[1] Power derating is performed when the ambient temperature is above 55°C.

# CHES Pro XC-B233-E-R1M01

Battery energy storage system for storage and charging, suitable for all kinds of EV charging and battery swapping stations.



## SYSTEM FEATURES



### Liquid Cooling & Excellent Performance

Using liquid cooling technology, cell-level intelligent temperature control ensures smooth operation. Ultra-long cycle life, product performance is greatly improved.



### Highly Integrated & Safe and Reliable

Integrate HVAC, FSS and BMS to monitor the operation status in real time in an all-round way, making it more efficient and safer.



### High-efficiency fast charging & Wide range of applications

Efficient charging and fast discharging, applicable to high-power fast-charging scenarios of electric vehicles. Simple and streamlined scalable design for extensive application scenarios.

## CIRCUIT DIAGRAM

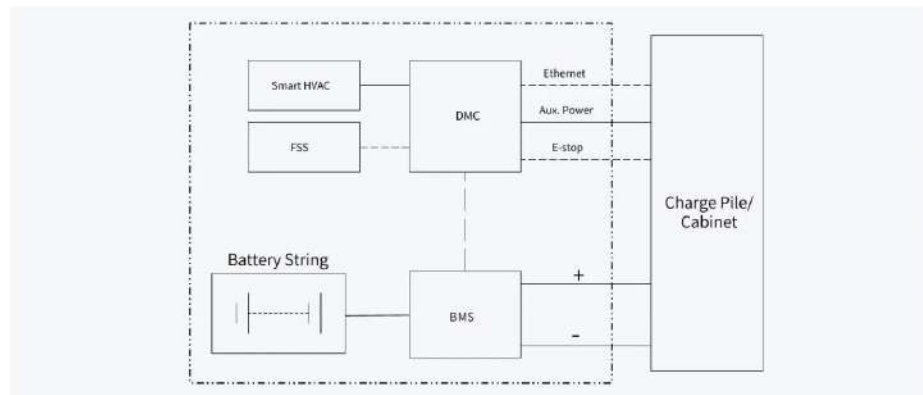

## SYSTEM PARAMETERS

System Type	XC-B233-E-R1M01
<b>DC Side</b>	
Cell Type	LFP C15
Cell Capacity	320Ah
Pack Type	1P57S
String Type	1P228S (4 battery packs)
System Configuration	1P228S
Battery Nominal Capacity (BOL)	233kWh
DC Usable Energy (BOL)@FAT	215kWh
DC Usable Energy (BOL) @SAT (within 3 months after FAT)	208kWh
Battery Voltage Range	592.8~820.8V
Nominal Charge/Discharge Power	100kW/200kW
<b>General Parameters</b>	
Dimensions(W×D×H)	1500×800×2250mm
Weight	≤2600kg
IP Rating	IP54(Electrical parts); IP65(battery part)
Operating Ambient Temperature	-25°C~+55°C 【1】
Storage Temperature	-20~35°C (<12 months); -20~45°C (<3months)
Relative Humidity	5%~95%
Max. Working Altitude	3000m
Cooling Concept	liquid cooling
Noise	≤75dB(A)@1m
Fire Suppression System	Aerosol
Aux. Power Interface	AC230V/50Hz
Aux. System Peak Power Requirement @45°C	5kW
Communication Interfaces	Ethernet
Communication Protocols	Modbus TCP/IP
Compliance	IEC62619,CE Marking
Standard Color	Front: MD458-3JA0-0; Side: RAL9011

Note:

【1】 Power derating is performed when the ambient temperature is above 45°C.

# Energy Pod ES8.6D&ES12.9D&ES17.2D

The Energy Pod DC residential energy storage system adopts high-performance lithium iron phosphate battery, which combine functional integration with modular design. The system includes EMS, and a DC battery box system. The installation and expansion are faster and more convenient. The system supports off-grid and off-grid applications. The entire system is based on the first generation of MiniES products Surface upgrade to meet the diverse needs of different customers.



## SYSTEM FEATURES



### All-in-one design

Highly integrated battery, BMS, wireless installation, and high safety for effectively protecting users.



### Modular design

Flexible capacity configuration, 8.64kWh-17.29kWh optional capacity. The capacity is scaled up to meet the needs of families also at any time.



### Easy to install

A single module weighs around 45kg and has a low installation cost.



### Wireless control

Support APP wireless control, support VPP application, etc.



### 10-year warranty

The battery is a guarantee for ten years.

## 户用 Energy Pod

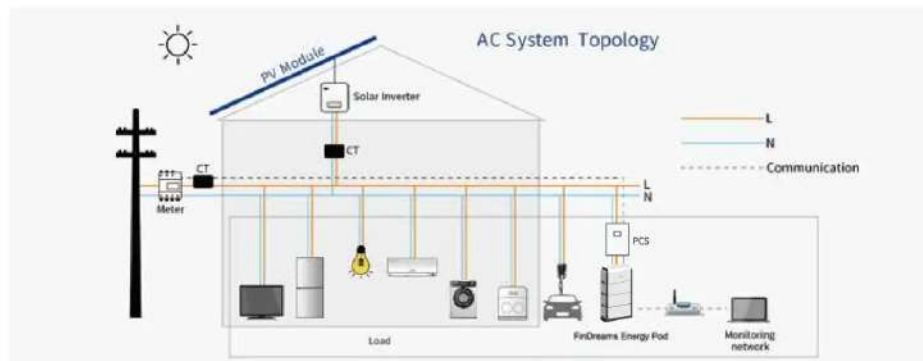

## SYSTEM PARAMETERS

Type	ES8.6D	ES12.9D	ES17.2D
<b>DC Data</b>			
Battery Box Quantity	2	3	4
BMS Box Quantity	1	1	1
Basement	1	1	1
Nominal Battery Capacity@DC side	8.6kWh	12.9kWh	17.2kWh
Available Battery Capacity	8.17kWh	12.255kWh	16.34kWh
Battery Nominal Voltage	204.8Vdc	307.2Vdc	409.6Vdc
Battery Voltage Min	172.8Vdc	259.2Vdc	345.6Vdc
Battery Voltage Max	225.6Vdc	338.4Vdc	451.2Vdc
Weight	≈156kg	≈201kg	≈246kg
Size (L*D*H)	626.6×316.2×948.6mm	626.6×316.2×1218.9mm	626.6×316.2×1489.2mm
Battery Module Weight	≈45kg	≈45kg	≈45kg
Battery Module Size (L*D*H)	626.6×316.2×270.3mm	626.6×316.2×270.3mm	626.6×316.2×270.3mm
Maximum Continuous Charge Power	4.3kW	6.45kW	8.6kW
Maximum Continuous Discharge Power	4.3kW	6.45kW	8.6kW
Maximum Discharge Peak Power	8.6kW(10S)	12.9kW(10S)	17.2kW(10S)
Maximum Operating Altitude	4000m	4000m	4000m
Relative Humidity	5%~95%	5%~95%	5%~95%
Operating Temperature	-10 - 50°C【1】	-10 - 50°C【1】	-10 - 50°C【1】
Communication	CAN RS485	CAN RS485	CAN RS485
Installation Mode	Floor installation	Floor installation	Floor installation
Protection Class	IP55	IP55	IP55
Certification Standard	UL 1973, UN 38.3, UL 1998, UL 991, IEC62619, CE Marking		

Note:

【1】 Power derating is performed when the ambient temperature is above 50°C.



# Energy Panel ES6.6DF

ES6.6DF residential energy storage system adopts a high-performance, ultra-safe lithium iron phosphate, with blade battery, which has the advantages of high security, complete functions, fast installation, APP control, friendly interface, and beautiful and generous.



## 系统功能



### High-end Design

The product adopts an integrated design combining wall-mounted and overall structure to reduce the wall-mounted space.



### Supporting Extension

This product has a storage capacity between 6.56kWh and 104.96kWh, which can be flexibly configured to achieve electricity demand for various families at different times.



### Mounting Type

The thickness of the product is only 80mm, which is perfectly integrated with the wall, which is in line with the ergonomic design.



### APP

The product supports wireless control and APP remote application.



### 10-year Warranty

The battery warranty period of the product is 10 years.

## Residential Energy Panel

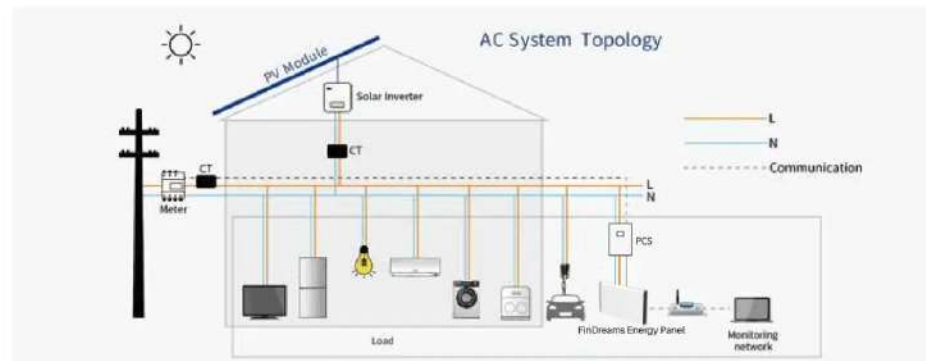

## SYSTEM PARAMETERS

Model	ES6.6DF
<b>DC Side</b>	
Cell Chemistry	LFP
DOD/%	100%
Available Battery Capacity/kWh	6.56kWh
Battery Nominal Voltage/Vdc	51.2Vdc
Battery Voltage Min/Vdc	43.2Vdc
Battery Voltage Max/Vdc	57.6Vdc
Weight(max)/kg	≈67kg
Size (L*D*H mm)	1050×80×580mm
Maximum Continuous Charge Power/kW	3.4kW
Maximum Continuous Discharge Power/kW	5kW
Maximum Discharge Peak Power/kW(10S)	11.7kW(10S)
Maximum Operating Altitude	4000m
Relative Humidity	5%~95%
Operating Temperature	Charge: 0-50°C Discharge: -10-50°C
cooling method	Natural convection
expansion capacity	16 P
Communication	CAN RS485
Mounting Type	Wall Mounting
Enclosure Protection Rating	IP55
Certification	IEC62619 IEC60730-1 CE UN38.3

# PROJECT CASES

04



Global Projects  
"0" Safety Accident in 16 Years

## Project Case-UK



## Project Case-China



## Project Case-USA



# SERVICE

05

AFTER-SALES SERVICE

BATTERY RECYCLING

  
Containerized Energy Storage System  
Made in China 50Wh

Professional | Efficient | Responsible

## After-sales service

### SERVICE CONCEPT



### 24-HOUR SERVICE



### GLOBAL SERVICE CENTER

#### BYD Global Energy Storage Service Center

BYD UK BYD US BYD EUR BYD AUS  
BYD JP BYD CHN Online Cloud Service

#### Service Centers in Regions

Branch(or service providers)  
BYD Engineers  
Warehouse for Spare Parts



## Battery Recycling

### RECYCLING PROCESS



### INDUSTRIALIZATION

